

## Matt Snell builds Metal-block flat car loads

» READ NOW

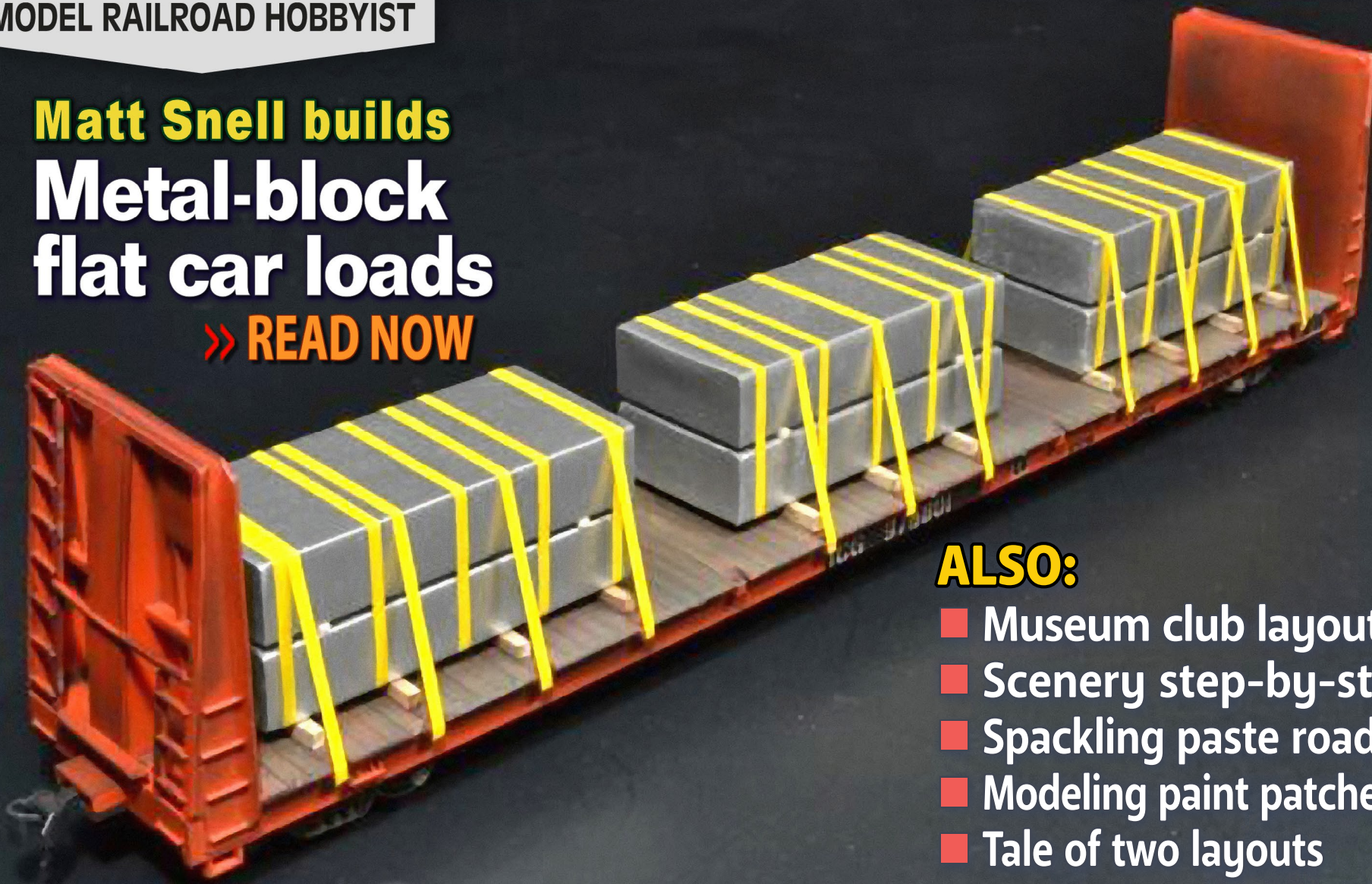

### ALSO:

- Museum club layout
- Scenery step-by-step
- Spackling paste road
- Modeling paint patches
- Tale of two layouts

*... and lots more inside!*

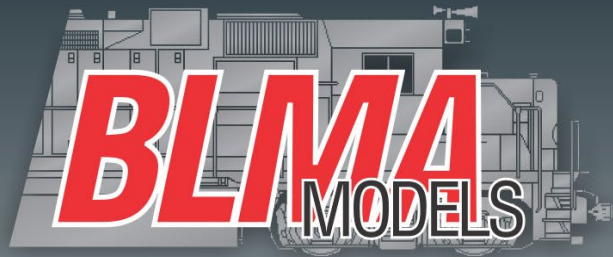

N SCALE

## LOAD 'EM UP

GSC 60' FLAT CAR



RUN #2

 SEE MORE NOW

- ▶ Prototypical Ride Height
- ▶ Die-Cast Metal Frame
- ▶ Extremely Fine Detail
- ▶ Trainline Air Hoses
- ▶ Body-Mounted Knuckle Couplers
- ▶ BLMA 70-Ton Trucks
- ▶ BLMA 33" Re-Designed Metal Wheels

[BLMAmodels.com](http://BLMAmodels.com)



MRHMAG.COM



Model Railroad Hobbyist | July 2015 | #65

## STAFF CREDITS

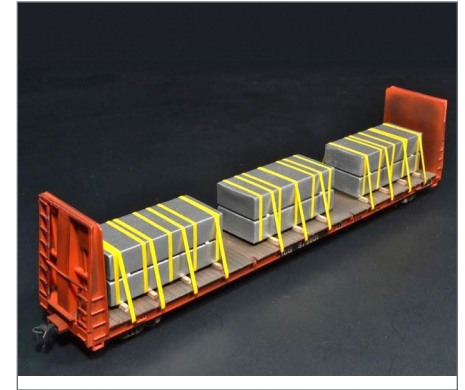
**Front Cover:** Matt Snell is back and he shows how to build these realistic metal-block loads for your flatcars, in this issue's cover story.



ISSN 2152-7423

**Editorial Staff**

Joe D. Fugate, Publisher and Editor  
Don Hanley, Assistant Editor

**Production**

Patty Fugate, pasteup and layout  
Joe Brugger, copy editing  
Mike Dodd, copy editing

**Technical Assistants**

Jeff Shultz  
Jimmy Simmons

**Advertising**

Les Halmos, Account Manager  
Daniel Nava, Advertising Assistant  
Jean-François Delisle, Marketing Assistant

**Columnists**

Richard Bale, News and events  
Jeff Shultz, News and events  
Les Halmos, Modular railroading  
Larry Smith, Narrow Gauge/Shortlines  
Bruce Petrarca, DCC  
Ken Patterson, Reporter at large

**Special Correspondents**

Joe Brugger, Questions & answers  
Charlie Comstock, Contributing editor  
Issue password: Jul2015

Published for the glory of God. [What's this?](#)

- [TABLE OF CONTENTS](#)
- [INDEX](#)



# MRH SPONSORS

## A - E



[acculites.com](http://acculites.com)



[americanlimitedmodels.com](http://americanlimitedmodels.com)



[railroadhobbyshow.com](http://railroadhobbyshow.com)



[anemodel.com](http://anemodel.com)



[archertransfers.com](http://archertransfers.com)



[athearn.com](http://athearn.com)

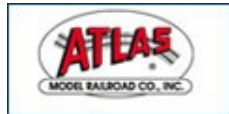

[www.atlasrr.com](http://www.atlasrr.com)



[bachmanntrains.com](http://bachmanntrains.com)



[bachrus.com](http://bachrus.com)



[backdropjunction.com](http://backdropjunction.com)

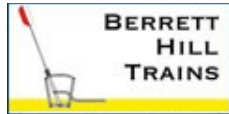

[berretthill.com/trains](http://berretthill.com/trains)



[blairline.com](http://blairline.com)



[blmamodels.com](http://blmamodels.com)



[bowser-trains.com](http://bowser-trains.com)



[caboosehobbies.com](http://caboosehobbies.com)



[coffmaneng.com](http://coffmaneng.com)



[con-cor.com](http://con-cor.com)



[cvrco.com](http://cvrco.com)



[www.digitrax.com](http://www.digitrax.com)



[crest-electronics.net](http://crest-electronics.net)



[esu.eu/en](http://esu.eu/en)

## F - R



[www.handlaidtrack.com](http://www.handlaidtrack.com)



[fiferhobby.com](http://fiferhobby.com)



[foxvalleymodels.com](http://foxvalleymodels.com)



[glxscalemodels.com](http://glxscalemodels.com)



[georgestrains.com](http://georgestrains.com)



[www.hobby-on.com](http://www.hobby-on.com)



[www.iascaled.com](http://www.iascaled.com)



[iwata-medea.com](http://iwata-medea.com)



[litchfieldstation.com](http://litchfieldstation.com)



[lundestudios.com](http://lundestudios.com)



[mapleleaftrains.com](http://mapleleaftrains.com)



[microscale.com](http://microscale.com)



[micromark.com](http://micromark.com)



[model-trains-video.com](http://model-trains-video.com)



[stores.ebay.com/Motrak-Models](http://stores.ebay.com/Motrak-Models)



[mthtrains.com](http://mthtrains.com)



[nano-oil.com/Model%20Railroad.html](http://nano-oil.com/Model%20Railroad.html)



[ngc-2015.com](http://ngc-2015.com)



[ncedcc.com](http://ncedcc.com)



[nickandnoradesigns.com](http://nickandnoradesigns.com)



[www.pwrs.ca/main.php](http://www.pwrs.ca/main.php)



[nmra2015portland.org](http://nmra2015portland.org)



[railmasterhobbies.com](http://railmasterhobbies.com)



[rapidotrains.com](http://rapidotrains.com)



[ringengineering.com](http://ringengineering.com)



[rr-cirkits.com](http://rr-cirkits.com)



[rslaserkits.com](http://rslaserkits.com)



[rustystumps.com](http://rustystumps.com)

[Vendors: Get your clickable logo here ...](#)

[Vendors: Get your clickable logo here ...](#)

MRH SPONSORS | 3

S - Z



[sanjuancarco.com](http://sanjuancarco.com)



[scenicexpress.com](http://scenicexpress.com)



[signaturepress.com](http://signaturepress.com)



[soundtraxx.com](http://soundtraxx.com)



[sodigi.com](http://sodigi.com)

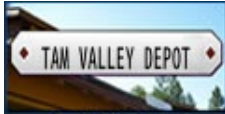

[tamvalleydepot.com](http://tamvalleydepot.com)



[tonystrains.com](http://tonystrains.com)



[trainfest.com](http://trainfest.com)



[trainteklc.com](http://trainteklc.com)



[trainworld.com](http://trainworld.com)



[walthers.com](http://walthers.com)



[yankeedabblers.com](http://yankeedabblers.com)

[Vendors: Get your clickable logo here ...](#)

Looking for something? Check our Hobby Marketplace!

Take me there!

MRHMAG.COM

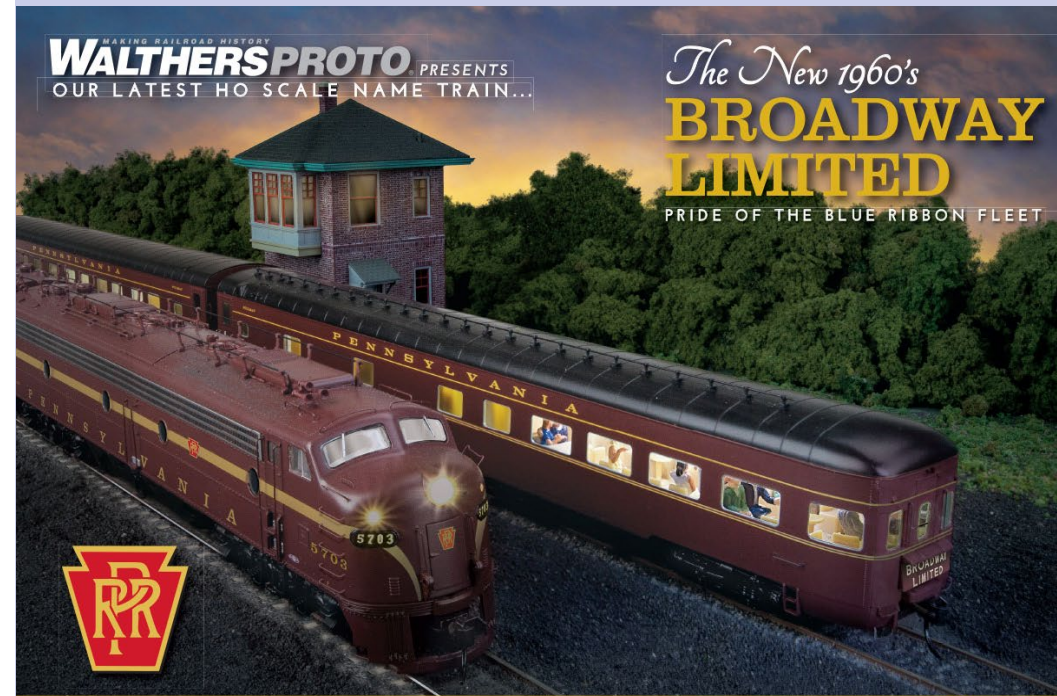

Pride of the Pennsylvania, the *Broadway Limited* was truly America's finest long-distance train of the 1960s, racing between New York and Chicago on red-hot 16-hour schedules, and serving a clientele accustomed to the very best. With an authentic consist of nine newly deskirted cars built to WalthersProto standards, our newest HO Scale name train also introduces a new Baggage-Mail car, rebuilt *Harbor* series sleeper-lounge, the later *View* series observation with large tail sign, and matching EP-22 diesel power.

Click Here to see the Complete Offer!

**Pennsylvania Class EP-22 (EMD E8A) Passenger Diesels**



**Broadway Limited Passenger Cars**



**First car arrives in September 2015 - reserve now!**

**WALTHERS** Support your local hobby shop • visit [walthers.com](http://walthers.com) • call 1-800-4-TRAINS

Prices and delivery dates shown were accurate at press time, for updates please visit [walthers.com](http://walthers.com). Photos show preproduction models for illustration purposes only, some colors and details may vary. ©2015 Wm. K. Walthers, Inc.

- [TABLE OF CONTENTS](#)
- [INDEX](#)



# TABLE OF CONTENTS

## FEATURES

### Scratchbuilt metal block flatcar loads

M. R. SNELL

Make these great-looking flatcar loads quite easily

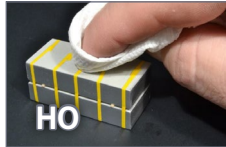

### Lewis County model railroad club

by the MRH STAFF

Club layout in an NP train depot turned museum



### Building a spackling paste road

KEN WOLF

Making model roads with this common material

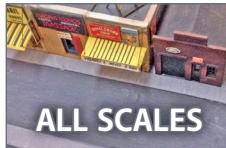

### Mid-Atlantic RPM meet

JOHN HUNTZINGER

What happened in 2014 and what's coming in 2015



### First Look: MRC Decoder Doctor

JEFF SHULTZ

MRH looks at MRC'S new decoder debugger



**ALSO:** Hobby Marketplace | Bonus downloads

## TABLE OF CONTENTS | 2

## COLUMNS

MRH Q-A-T: Patch jobs, Windex and airbrushes ...

... compiled by JOE BRUGGER

DCC Impulses: DCC garden wiring tips

... BRUCE PETRARCA

Getting Real: Finishing an entire aisle, part 1

... MIKE ROSE

Lite & Narrow: New Merkle Connecting, part 3

... LARRY SMITH

What's Neat: More 3D-printed autos ...

... KEN PATTERSON

Imagineering: Tale of two layouts

... VERNE NINER

Photo feature: Yes, it's a model

... compiled by DON HANLEY

Derailments: Bizarre facts & humor

... compiled by the MRH STAFF

## NEWS and EDITORIAL

Publisher's Musings: Heavier cars = better performance?

... JOE FUGATE

Staff notes: Making the hobby more satisfying ...

... compiled by the MRH STAFF

News & Events: July 2015

... RICHARD BALE & JEFF SHULTZ

Reverse running: No use for Homasote

... JOE FUGATE



# N AND HO FREIGHT CARS

MECH  
REEFER  57  
FEET



## ANNOUNCEMENT FGE 57' MECHANICAL REEFER NOW IN N-SCALE

By popular demand, Athearn® is offering the Fruit Growers Express 57' Mechanical Reefer in HO and in N-scale! These models made their debut at the Milwaukee Trainfest 2014 and are now arriving at your favorite dealer. These reefers make any set cool!

### N-SCALE NON-SOUND \$29.98 WITH SOUND \$59.98

ATH24862	ATH24762	N 57' Mechanical Reefer, FGE #11984
ATH24863	ATH24763	N 57' Mechanical Reefer, FGE #12028
ATH24864	ATH24764	N 57' Mechanical Reefer, FGE #12145
ATH24865	ATH24765	N 57' Mechanical Reefer, FGE #12269
ATH24866	ATH24766	N 57' Mechanical Reefer, FGE/Solid Cold #12824
ATH24867	ATH24767	N 57' Mechanical Reefer, FGE/Solid Cold #12904
ATH24868	ATH24768	N 57' Mechanical Reefer, FGE/Solid Cold #12873
ATH24869	ATH24869	N 57' Mechanical Reefer, FGE/Solid Cold #12918
ATH24870	ATH24770	N 57' Mechanical Reefer, BNFE #11702
ATH24871	ATH24771	N 57' Mechanical Reefer, BNFE #11910
ATH24872	ATH24772	N 57' Mechanical Reefer, BNFE #12445
ATH24873	ATH24773	N 57' Mechanical Reefer, BNFE #12547
ATH24874	ATH24774	N 57' Mechanical Reefer, BNSF/WFE #799767
ATH24875	ATH24775	N 57' Mechanical Reefer, BNSF/WFE #799772
ATH24876	ATH24776	N 57' Mechanical Reefer, BNSF/WFE #799786
ATH24877	ATH24777	N 57' Mechanical Reefer, BNSF/WFE #799790
ATH24878	ATH24778	N 57' Mechanical Reefer, BNSF/WFE #799793
ATH24879	ATH24779	N 57' Mechanical Reefer, BNSF/WFE #799798
ATH24880	ATH24780	N 57' Mechanical Reefer, UP/ARMN #912057
ATH24881	ATH24781	N 57' Mechanical Reefer, UP/ARMN #912998
ATH24882	ATH24782	N 57' Mechanical Reefer, UP/ARMN #922040
ATH24883	ATH24783	N 57' Mechanical Reefer, UP/ARMN #922047
ATH24884	ATH24784	N 57' Mechanical Reefer, UP/ARMN #922015
ATH24885	ATH24785	N 57' Mechanical Reefer, UP/ARMN #992989

### N-SCALE REEFER FEATURES:

- Brand new tooling • Separately installed photoetched stirrups • First Athearn® N-scale freight car available with onboard sound – the Genset or refrigeration unit cycles on and off • McHenry® scale knuckle spring couplers • Machined metal wheels • Minimum radius: 11" • Modern FGE reefers include Gensets that are visible through openings on the roof and body sides



### HO-SCALE AVAILABLE FOR PRE-ORDER NON-SOUND \$49.98 WITH SOUND \$89.98

ATHG63056	ATHG63356	HO 57' Mechanical Reefer, BNFE #9251
ATHG63057	ATHG63357	HO 57' Mechanical Reefer, BNFE #9265
ATHG63058	ATHG63358	HO 57' Mechanical Reefer, BNFE #9269
ATHG63059	ATHG63359	HO 57' Mechanical Reefer, FGE/Solid Cold #12836
ATHG63060	ATHG63360	HO 57' Mechanical Reefer, FGE/Solid Cold #12898
ATHG63061	ATHG63361	HO 57' Mechanical Reefer, FGE/Solid Cold #12914
ATHG63062	ATHG63362	HO 57' Mechanical Reefer, Frisco #333009
ATHG63063	ATHG63363	HO 57' Mechanical Reefer, Frisco #333027
ATHG63064	ATHG63364	HO 57' Mechanical Reefer, Frisco #333048
ATHG63065	ATHG63365	HO 57' Mechanical Reefer, TPIX #136
ATHG63066	ATHG63366	HO 57' Mechanical Reefer, TPIX #138
ATHG63067	ATHG63367	HO 57' Mechanical Reefer, TPIX #140
ATHG63068	ATHG63368	HO 57' Mechanical Reefer, UP/ARMIN #922012
ATHG63069	ATHG63369	HO 57' Mechanical Reefer, UP/ARMIN #922036
ATHG63070	ATHG63370	HO 57' Mechanical Reefer, UP/ARMIN #922049



Model Railroad Hobbyist | July 2015 | #65

# PUBLISHER'S MUSINGS

editorial

JOE FUGATE



Click here for  
reader comments

## HEAVIER CARS = BETTER PERFORMANCE?

WHEN I VISITED MIKE CONFALONE'S ALLAGASH operating session in 2013 to video the footage for *Ops Live* volumes 5 and 6, I was impressed with how well everything ran. In fact, I saw *no derailments* during the entire six-hour operating session. That's quite a feat.

In my interview with Mike after the operating session (available on [TrainMasters TV](http://TrainMastersTV.com), running time: 78 min), I learned that Mike deliberately overweighted his cars by at least 2x the NMRA RP for car weight in HO (see: [nmra.org/rp-201-car-weight](http://nmra.org/rp-201-car-weight)).

Mike says this extra weight changes the train dynamics on the model such that it feels much more like you're moving tonnage, and cars simply stay on the track better. Mike talks about this extra weight and other such philosophies for getting more reliable layout performance in his Allgash Story eBook series ([store.mrhmag.com/store/p46/Allgash\\_Story\\_vols\\_1-4\\_%28Download%29.html](http://store.mrhmag.com/store/p46/Allgash_Story_vols_1-4_%28Download%29.html)).

I was so impressed with the performance on Mike's Allgash that I've elected to overweight some of my cars and see what different it makes. In my case, I'm adding one ounce per inch of car length over the couplers. On a 40-foot car, it's about six inches, so it gets six ounces. On 50-foot cars, they're about 7.5 inches over

HORIZON  
H O B B Y

VISIT  
Your Local Retailer

CLICK  
Athearn.com

CALL  
1.800.338.4639

SERIOUS FUN®

©2015 Horizon Hobby, LLC. Athearn, Genesis, Ready To Roll, Trains in Miniature, Serious Fun and the Horizon Hobby logo are trademarks or registered trademarks of Horizon Hobby, LLC. The Union Pacific mark and other marks owned by Union Pacific are made under trademark license from Union Pacific Railroad Company. All other trademarks, service marks and logos are property of their respective owners. Final models may vary slightly from photos shown. 4936

MRHMAG.COM

• [TABLE OF CONTENTS](#)  
• [INDEX](#)

## PUBLISHER'S MUSINGS | 2

the couplers, so they get 7.5 ounces. On boxcars and other closed cars, adding the extra weight is easy – I'm just using pennies. On open-top cars like flatcars and gondolas, things get trickier.

In my testing, on my lightly graphited rails ([see the May 2015 issue of MRH](#)) I'm finding a six-axle HO diesel will pull about 5 cars up a 2.5% grade.

So how does this work for me, since I model the Southern Pacific and they ran long trains on the Siskiyou Line, 100 car+ trains?

I obviously could not run 100 car trains on my layout. I just don't have the space. But I wanted to find out what was "long enough" so I did some experiments back when I was designing the layout in the early 1990s. I found a train that's 15 actual feet long felt really long. In HO, that's 30 40-foot cars, or 24 50-foot cars.

ADVERTISEMENT

### Now Shipping from Atlas!

Atlas Master® N GP-40/40-2 Locomotive



For the most up-to-date information on Atlas arrivals

[Click Here](#)

ADVERTISEMENT

**HO  
SCALE**

Item No. 63907 • SEABOARD #1633 **NEW**

## BACHMANN'S SOUND VALUE ALCO RS-3: NOW IN FOUR NEW ROADNAMES!

Bachmann's DCC sound-equipped model includes our Sound Value *SoundTraxx*® diesel sound package with prototypical prime mover, 3 air horns, and bell—all in 16-bit polyphonic sound. Also featuring a die-cast chassis, all-wheel drive, and a precision can motor with dual precision-balanced flywheels, the RS-3 is now available in four new roadnames. Visit your favorite hobby dealer to enjoy the RS-3 Diesel's many features plus great sound at a Sound Value price!

Features include:

- DCC-sound equipped
- die-cast chassis
- all-wheel drive
- precision can motor
- dual, precision-balanced flywheels
- super-quiet, helical cut gears
- metal cut levers
- finescale handrails
- blackened metal wheels
- prototype-specific directional headlights
- RP25 wheel contours
- E-Z Mate® Mark II couplers



CP RAIL #8438 - MULTIMARK  
Item No. 63902



BOSTON & MAINE #1536  
Item No. 63903



ERIE #932  
Item No. 63904



GREAT NORTHERN #229  
Item No. 63906



SANTA FE #2099  
Item No. 63908



INTERSTATE #31  
Item No. 63909

Click to learn more.

**SHIPPING NOW! MSRP \$239.00 each**

Bachmann Industries, Inc. • 1400 East Erie Avenue • Philadelphia, PA 19124 USA • [www.bachmanntrains.com](http://www.bachmanntrains.com)

Click for more information.





**SmartSwitch™** **ANE model**

**SmartSwitch is your first choice**

- ✓ SmartSwitch is a slow motion turnout machine
- ✓ One SmartSwitch control 4 turnouts
- ✓ More accessories for SmartSwitch to control your layout
- ✓ Intelligent design, make your servo longer life



**Archer**  
FINE TRANSFERS  
PROUDLY SERVING MODEL BUILDERS SINCE 1989

THE ORIGINAL  
**SURFACE DETAILS™**

WE NOW HAVE MORE THAN 100 SHEETS OF RIVETS, LOUVERS, TREADPLATE AND MORE CAST ONTO MICROSCALE CLEAR DECAL FILM

**FREE SHIPPING:**

- DOMESTIC USA ORDERS \$50 OR MORE
- INTERNATIONAL ORDERS \$100 OR MORE

CLICK HERE TO VISIT OUR WEBSITE!

Archer Fine Transfers • PO Box 1277 • Youngsville, NC 27596 • USA  
(919) 570-1026 • info@archertransfers.com • archertransfers.com

*"Archer rivets are easy to apply and look great. To me, they are now a vital tool in building railroad models."*  
Tony Thompson, Model Railroad Author/Historian

MADE IN THE USA

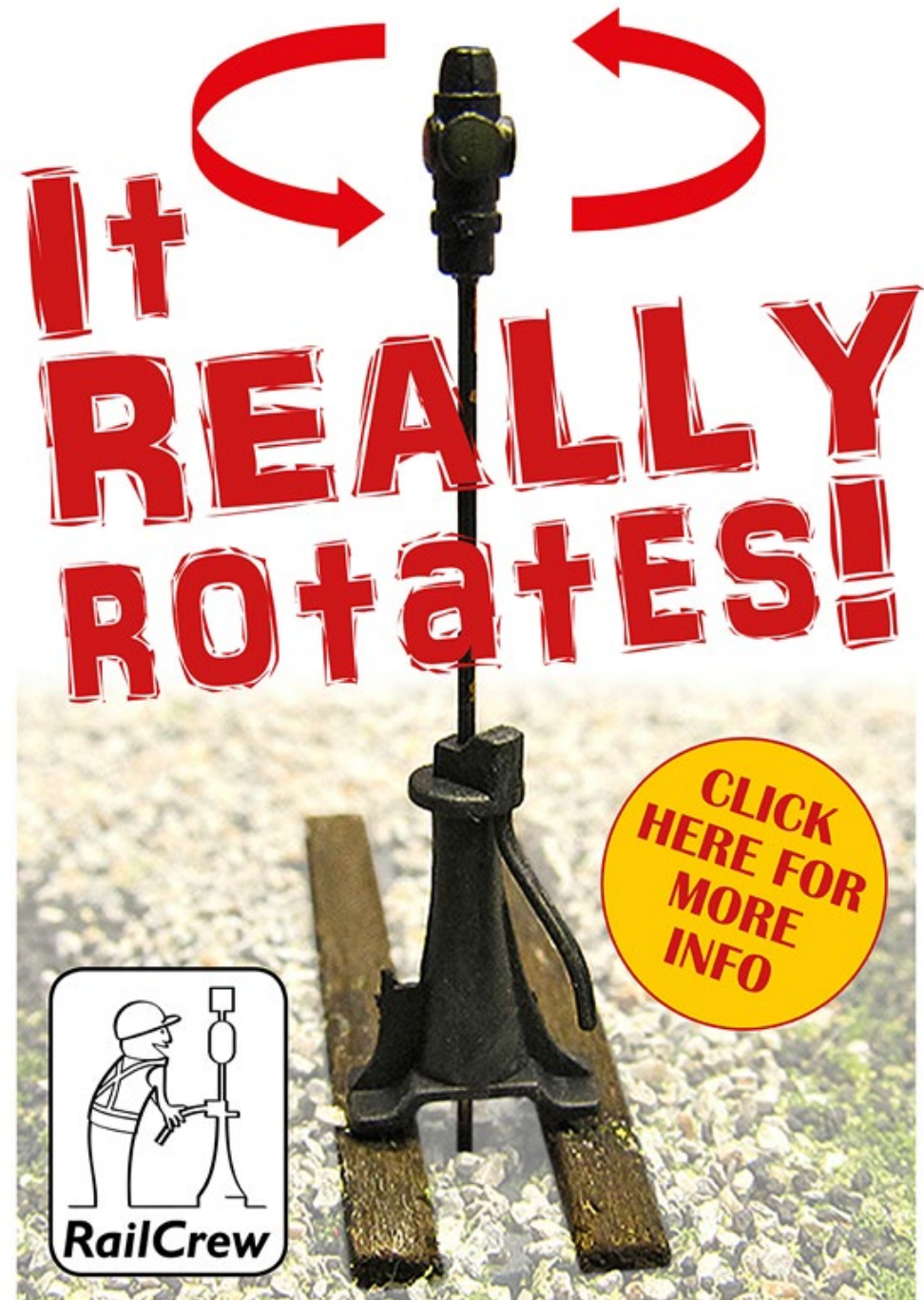

**It REALLY ROTATES!**

CLICK HERE FOR MORE INFO



**RailCrew**

## PUBLISHER'S MUSINGS | 3

I found the trick was to get a train long enough to extend past my field of vision on both sides when I was just a foot away from it. I'm assuming narrow shelf benchwork here. Once I could do that, then more length didn't matter – it felt plenty long.

Now, the SP would also run at least three units at the head end of these long trains, and two units mid-train as helpers. In my era of the 1980s, they still ran cabooses. That means I need at least five locos plus one "cab" on the end. I designed my longest sidings to be 18 feet, to allow another 3 feet for the locos and a cab.

To give some room for slop, I figure 23 cars max. Each loco needs to pull 5 cars (4.8 actually, but I round up) over a maximum of a 2.5% grade. Hey, that matches my weight testing!



## PUBLISHER'S MUSINGS | 4

I've also found that if you're overpowered on the grade and actually don't need the helpers, you're much more likely to throw stuff on the ground. It's turning out the extra weight (plus a very light graphite application on the rails) is just about perfect for what I'm after.

An 18-foot train is easily long enough to feel LONG. Once you see this much train on the layout, it does feel like you're really railroading because you can't see all of a train most of the time.

Just for the fun of it, Roseburg yard was jammed one time, so we ran a 40-car train with an added rear helper set to go with the usual mid-train helpers and the locos on the point. What a blast! Two helper crews and a head-end crew to boot. Be interesting to see how well this would work with the new overweight cars.

There is now a lively discussion on the MRH forum about overweighting after I brought the topic up recently. If you'd like to read more, or contribute to the discussion, then head on over to the MRH forum at: [mrhmag.com/node/22784](http://mrhmag.com/node/22784). There's a related discussion on train length, and you will find that at: [mrhmag.com/node/22818](http://mrhmag.com/node/22818).

Overweighting isn't for everyone, but for me, the results so far are promising.

Follow my Siskiyou Line progress [on my MRH blog...](#)



Click here for  
reader comments

ADVERTISEMENT

**Trainfest**  
America's Largest Operating Model Railroad Show

NEW  
**2 DAY  
TICKETS**  
AVAILABLE JULY 1

56 CLINICS

**JOIN  
THE  
FUN**

**FIND THE  
ADVENTURE**

Saturday & Sunday  
Nov. 14 - 15, 2015

9:00am-  
5:00pm

WI State  
Fair Park  
Milwaukee (West Allis), WI

Sponsored by the Wisconsin Southeastern Division, Inc. of the National Model Railroad Association

DON'T MISS AN ORIGINAL ARTWORK OF  
THE MILWAUKEE DEPOT AND THE C&NW  
Prints Available for Purchase

Ticket discounts and show details at  
**Trainfest.com**

Celebrating the Chicago & North Western System

This is the beginning of an exciting new tradition for Trainfest. Each year we will be celebrating a railroad through sharing memories and photos, partnering with historical societies, and modeling that road.

**HAVE A MEMORY OF THE C&NW?**

Did you work for the C&NW?  
Did you ride the C&NW?

Submit your photos and stories to Trainfest at [info@trainfest.com](mailto:info@trainfest.com)



**NO WORRIES  
WARRANTY**

## **Digitrax No Worries Warranty Keeps Your Layout Running!**

**That's it! A simple, straightforward one year warranty with no tricky language!**

**You're protected against defects and accidental damage.**

**Learn more at: [www.digitrax.com/noworries](http://www.digitrax.com/noworries)**

**Need tech support?**

**[www.digitrax.com/contact](http://www.digitrax.com/contact)**

**Need a repair?**

**[www.digitrax.com/repair](http://www.digitrax.com/repair)**

**Need a throttle conversion?**

**[www.digitrax.com/upgrade](http://www.digitrax.com/upgrade)**

# HAPPY 4TH SALE!

## save 17.76%

on **ALL**

**Model Railroad  
Hobbyist** *Store*

### Purchases!

*Sale ends midnight July 9th*

Use coupon code at checkout: **HAPPY4TH**

**Shop now  
and save!** >>



Model Railroad Hobbyist | July 2015 | #65

## STAFF NOTES



[Click here for  
reader comments](#)

### MAKING THE HOBBY MORE SATISFYING ... AND MORE

**A COMMON QUESTION ON MODEL RAILROAD-**ing forums is: “I’m new to the hobby, how do you recommend I get started?” Another common question that is related is: “I have this space for a layout, but I haven’t got a clue how to develop a track plan for the space. Can you guys help me come up with a track plan?”

At the heart of both questions is the same root request: How do I proceed so the hobby will be the most satisfying to me?

Most seasoned modelers know how to answer this: you need to learn what parts of the hobby you like best and what parts of the hobby you like least. To do that, you need to do some learning. For example, in this issue’s article on the Lewis County club, Ted Livermore had this advice for hobby newcomers:

*“Put a loop of track down and keep it running ... then go visit different layouts and clubs, learn what you can learn – and find out what you’re interested in.”*

Exactly! But even those of us who have been in the hobby for a while may have gotten stale and need a refresher, too.

## STAFF NOTES | 2

Let's take the example of someone who has an empty space and doesn't have the first notion of where to start on a track plan.

To do a track plan, first you need to know what different track arrangements do and why they exist. The best way to learn that is to go run some trains on layouts that do prototypical operation. Real railroads don't do different track arrangements because they look cool or add variety to things – laying track costs money so they lay the least amount of track to do the job.

Another good idea is to join the Layout Design Special Interest Group (LDSIG, see their web site: [ldsig.org](http://ldsig.org)). The LDSIG publications give you much insight into why some track plans work, and why some don't. The LDSIG now offers a \$16 per year eJournal membership, which is a bargain! Also check out back issues of the LDSIG Journal, they're a gold mine of track planning tips and tricks.

Once you know what all those tracks are for, then what? Next, you need to determine what kind of layout would be the most satisfying for *you* to model. Do you want a granger line? Do you know what a granger line is? A mountain railroad with helpers? A city line with intense passenger operations? Or perhaps a backwoods branchline in the hills?

You can learn this by visiting many different kind of layouts, and asking the owners enough questions to see which one appeals to you the most.

So how do you do that? First, visit local swap meets and/or local clubs and find out what layouts are in your area that you can visit.

Another good way to visit such layouts is to join the Operations Special Interest Group (OPSIG for short, see their website: [opsig.org](http://opsig.org)). An eZine membership to the OPSIG is just \$7 per year.



## LAST ISSUE'S RATINGS

The five top-rated articles in the [June 2015 issue](#) of *Model Railroad Hobbyist* are:

- 4.6 Realistic conifers
- 4.4 DCC Impulses: DCC stationary decoders
- 4.4 Shaun Toman's UP Oregon Division
- 4.3 Imagineering: Believable fantasy, the In-Ko-Pah RR
- 4.3 Better blue box electrical performance

Issue overall: **4.5**

**Please rate the articles!** Click the reader comments button on each article and select the star rating you think each article deserves. Thanks! ■

### ADVERTISEMENT



**The World's Largest Model Train Store!**

Model trains G to Z, DCC, brass models, kits, RTR, collectable models, scenery, structures, books, magazines, DVD's, hobby tools & supplies and a full service repair department.

[WWW.CABOOSEHOBBIES.COM](http://WWW.CABOOSEHOBBIES.COM)

**CABOOSE HOBBIES**  
WORLD FAMOUS MODEL TRAIN STORE  
Since 1938!

START SOME FUN!  
**CLICK HERE!**



- [TABLE OF CONTENTS](#)
- [INDEX](#)

## STAFF NOTES | 4

With the OPSIG, you can get yourself invited to layout op sessions all around the US and Canada, and sometimes even outside North America. The OPSIG also hosts layout op events at major conventions, such as at the NMRA National this year in Portland, Oregon. Publisher Joe Fugate's Siskiyou Line is hosting guest operators at the convention's OPSIG event, as is Charlie Comstock with his Bear Creek & South Jackson.

Don't overlook video resources. TrainMasters TV has just released its first volume of layout tours on DVD. We watched each layout story as it was released in TMTV Season 1, but seeing all 16 of these stories collected into a DVD set and watching them end-to-end totally blew us away. You can say we're biased, but we're modelers too, remember. This is one awesome DVD set!

## STAFF NOTES | 5

Each layout segment gets inside the head(s) of the layout creators and aims to understand what makes them tick. That's exactly the kind of information you need to answer the questions we are discussing here. [Check out this layout DVD set](#) on the MRH Store.

And when it comes to operations and videos, there's also our Ops Live series, which now includes six volumes. Essentially, these are model railroading ops reality videos. We take a video camera to layouts that do serious operation and start rolling. We don't follow a script; things just unfold as they really happen at the op session.

There's certainly some tutorial value in the Ops Live videos, but they're *not* how-to-do-ops videos. They assume you know at least a little of the basics of realistic operation, and that you'd like to see how "they" do it – namely, the layouts we feature in Ops Live. The

ADVERTISEMENT

### Checked us out lately?



WHAT'S NEW?  Established 1993...  
**Blair Line**

MRHMAG.COM

ADVERTISEMENT

**Backdrop Junction**  
Your Stop for Railroad Backdrops

**Click Here** 

**For the Finest in Custom  
Designed backdrop**



[www.backdropjunction.com](http://www.backdropjunction.com)

ADVERTISEMENT



**Your Local N Scale  
Online Hobby Shop**

575-523-9743  
[fiferhobby.com](http://fiferhobby.com)

- [TABLE OF CONTENTS](#)
- [INDEX](#)

layouts are: Joe Fugate's Siskiyou Line, Charlie Comstock's Bear Creek & South Jackson, and Mike Confalone's Allagash Railway.

For more on our Ops Live video series, [see the MRH Store](#).

To summarize, exposing yourself to an array of fresh hobby experiences though rubbing shoulders with other modelers either in person or through videos will clarify your desires and help you see what truly satisfies *you* the most in the hobby.

### Siskiyou Line update

Speaking of operations, Joe Fugate just had his second operating session on his Siskiyou Line after it had been mothballed for three years. This second session had a decent attendance with 11 people showing up.

You can read all about it [here on Joe Fugate's blog](#), with photos.

All-in-all, the layout ran pretty well for this second time out in three years. Joe has upgraded the DCC short handling on his Siskiyou main. He's also adding weight to cars. He cleaned the rails and cleaned and put a light application of graphite on the track. Finally, Joe upgraded the decoder speed tables in his locos to make them more responsive.

The crews from this op session felt conductivity was excellent (thank you graphite) and the new loco speed curves indeed did make the locos feel more like they responded to the throttles better.

In short, a great success as Joe marches toward August, where eight guest operators get to try their hand at putting the Siskiyou Line through its paces.

### What's new on the MRH website?

Here's our monthly listing of some interesting posts.

Layout's establishing scene? [mrhmag.com/node/22888](http://mrhmag.com/node/22888)

Switching at Quisling, CA: [mrhmag.com/node/22908](http://mrhmag.com/node/22908)

Scratch building O-scale flatcars: [mrhmag.com/node/22842](http://mrhmag.com/node/22842)

Going from schematic to circuit board: [mrhmag.com/node/22879](http://mrhmag.com/node/22879)

Layout room prep: [mrhmag.com/node/22280](http://mrhmag.com/node/22280)

Polish those old Athearn wheels: [mrhmag.com/node/16333](http://mrhmag.com/node/16333)

Rustoleum for track painting: [mrhmag.com/node/22808](http://mrhmag.com/node/22808)

Add lights to a BLI Trackmobile: [mrhmag.com/node/22882](http://mrhmag.com/node/22882)

ADVERTISEMENT



WE ONLY SELL WHAT WE MANUFACTURE

**DETAILS** IN HO, O, S & N SCALES  
LASER CUT SHINGLES, DOORS & WINDOWS,  
FENCES, SIDING, CRATES. Also RESIN and  
WHITE METAL DETAILING CASTINGS.

**CRAFTSMAN KITS**  
IN HO, O & S SCALES

CHECK IT ALL OUT AT  
**WWW.RUSTYSTUMPS.COM**

Send \$3.50 for Catalog - Specify Scale  
**RUSTY STUMPS SCALE MODELS**  
6785 Cherry Blossom W. Dr., Fishers IN 46038  
Phone (317) 595-9489

## STAFF NOTES | 8

Paint fade on rolling stock: [mrhmag.com/node/22478](http://mrhmag.com/node/22478)

Shadow box and LED lighting: [mrhmag.com/node/22389](http://mrhmag.com/node/22389)

We hope July's MRH is a great read for you!



Click here for  
reader comments

Get the Latest Model Railroading News, Tips, Reviews & Opinions

# The SCOTTY MASON SHOW

S H O W  
*The Original Model Railroad Podcast*

- Monthly Interviews
  - Modeler's Spotlight: Top Modeler's Talk
  - Narrow Gauge Modeling w/Chris Lane
  - Contemporary Modeling w/ Mike Rose
- More Product Announcements & Reviews

Our feed has changed! To get the latest shows, Please search Scotty Mason and subscribe to the new feed!

[www.TheModelRailroadPodcast.com](http://www.TheModelRailroadPodcast.com)

Scott Mason Jimmy Simmons Mike Rose Joe Duckworth

### ADVERTISEMENT



Announcing  
**Motrak Models Flat Paint  
Made by Scalecoat:**

Rail Brown – White – Black - Silver  
Aluminum – Oxide Red – RR Grime #1  
RR Grime #2 – Boxcar Red – Roof Brown  
Aged Concrete – Dirt – Sand - Rust  
MOW Gray – Engine Black

Limited quantities - place your order now!  
We still have other colors available from Scalecoat.

**Phone number: 813-476-4784**  
**Email: [motrakmodels@centurylink.net](mailto:motrakmodels@centurylink.net)**

**CHECK  
IT OUT!**

### ADVERTISEMENT

## HO & N SCALE HIAWATHAS

FINAL BOARDING CALL FOR MORE  
CARS AND LOCOMOTIVES!  
NOW AVAILABLE WITH SOUND!

**RESERVE  
TODAY!** [www.foxvalleymodels.com](http://www.foxvalleymodels.com)

### ADVERTISEMENT

## NICK & NORA DESIGNS

Uniquely inspired craftsman kits

Craftsman Structure Kits,  
Detail Parts, Shingles & More!  
[www.nickandnoradesigns.com](http://www.nickandnoradesigns.com)

Nick & Nora Designs  
a division of:  
TMB Custom Models

New  
Innovation

**Nano-Oil™**  
Made in U.S.A.

Nano Technology Lubricants

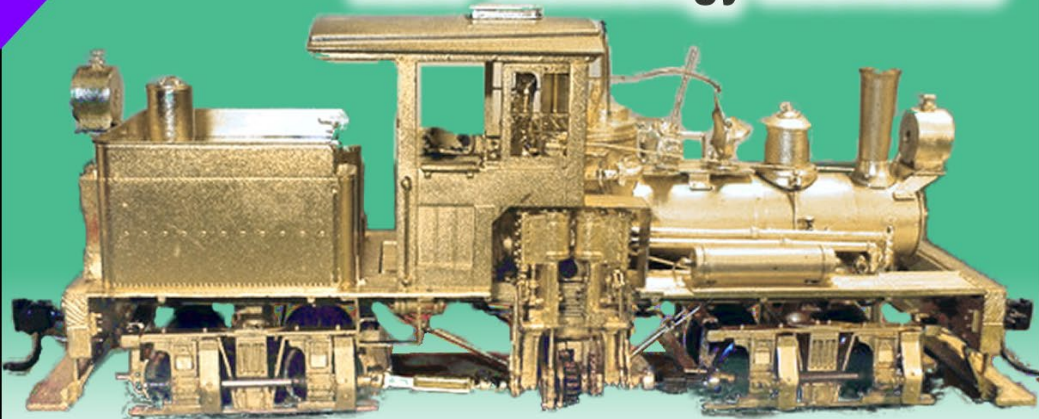

"After eight years of extensive testing, the only lubricants now used in my shop are Nano-Oils and Nano-Grease. The extreme reduction in power draw by mechanically minimizing friction is simply technologically superior."

- Phil Floyd, 'The Shay Fixer'

**THE SHAY FIXER** 

VISIT US AT... **SHAYFIXER.COM** 

*Specializing in brass Pacific Fast Mail / United geared locomotives*

For more details  
click here ...

Model Railroad Hobbyist | July 2015 | #65



**MRH Q-A-T**  
column

compiled by  
**JOE BRUGGER**



Click here for  
reader comments

## ? QUESTIONS AND ANSWERS

### Patch jobs

**Q.** When a modern-era freight car changes hands, does the new owner have to at least patch the reporting marks? Or could it happen that a car has a new owner but no visible change on the car? How can you find out which car was bought by which railroad, and which car numbers were used? How do you apply these patches on your models? Self-made decals aren't an option, because you would often need white letters on black and most people do not own a printer which can print in white.

—engineer

**A. Jim (jamnest):** When the Rock Island went bankrupt, CNW acquired a lot of its rolling stock. Many grain cars kept the ROCK car numbers and blue paint, with just the ROCK/RI reporting mark painted out and replaced with CNW.

► MRH QUESTIONS, ANSWERS, AND TIPS



## MRH Q-A-T | 2

**Gsinos:** Union Pacific acquired a lot of cars through purchase or merger. They didn't patch the reporting marks on a lot of them (generally cars from merged lines), they just put a UP shield on the side and called it a day. Some don't even get the shield.

**BarrCEO:** Printers won't print white but they will print a black square or rectangle with the lettering clear. Just paint or decal a white background behind the patch and let it show through. I anticipated that problem, and had decals made in black, and the same in white. I can use white over black for a "drop shadow" effect, and white alone for patch jobs.

**Rob Spangler:** Unless the new owner also owns the entity to which the old reporting marks belong, then yes, the reporting marks must be changed. Large roads that absorb others



1. This patch job is done with custom-made commercial decals. *BarrCEO photo*

## MRH Q-A-T | 3



2. This car has not changed ownership, but has multiple patches from repairs and changes to stenciling. The capacity data is white, decaled atop the oxide red patch. *Rob Spangler photo*

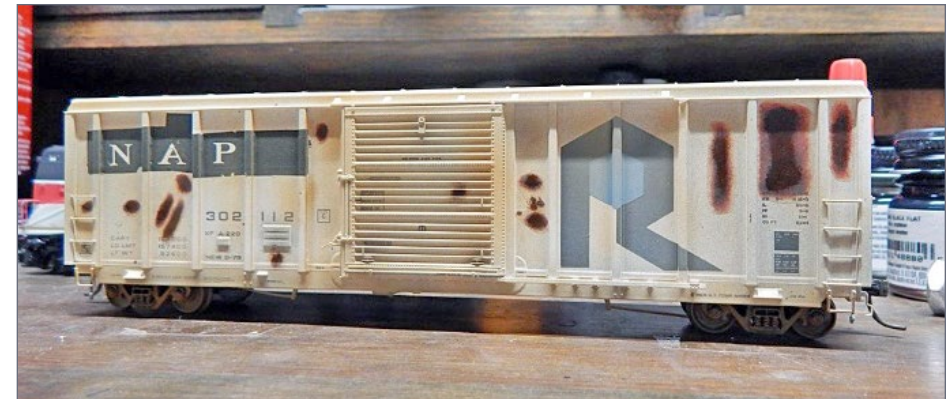

3. Hobbez, who blogs at [hobbeziun.blogspot.com](http://hobbeziun.blogspot.com), left the remnants of a Rock Island logo on this car and saved the original data and number, but painted out and replaced the reporting mark. *Hobbez photo*

through merger also end up owning the rights to the former railroad entities, and can continue using them.

The Union Pacific controls roads acquired through mergers, including various subsidiaries, so they can continue with MP, WP, CNW, SP, SSW, CEI, MKT, CHTT, CMO and so on. All those are now part of the UP. Should another entity acquire the car, they no longer have any right to use the former owner's initials and would have to patch them out. The car number wouldn't have to change unless the new owner wanted to do so.

**Note:** Test your printer and decal paper. Some printers can print on white decal paper, leaving characters to show through. You can also decal in layers, using solid colors for paint-outs and additional decals on top of them.

**Prof\_Klyzlr** suggests studying [railcarphotos.com](http://railcarphotos.com) to trace freight car ownerships and patch-outs. The photos are a great resource for weathering and numbering projects.

See the original MRH Forum thread at [model-railroad-hobbyist.com/node/22483](http://model-railroad-hobbyist.com/node/22483).

### Trix/Marklin couplers

**Q.** I pulled my much-loved Trix Big Boy off the shelf to find the tender coupler missing. I found the coupler, but it needs to be replaced, and the original equipment's height has always been far too low for reliable operation. It is one of the Marklin/Trix pull-out variety. There is a centering spring attached to the coupler box that seems to be pulling the coupler down a bit. I can't just eliminate the spring, though, or the coupler will not center well. I would really prefer to install a Kadee coupler that accounts for this to provide the desired height.

—cruizer219

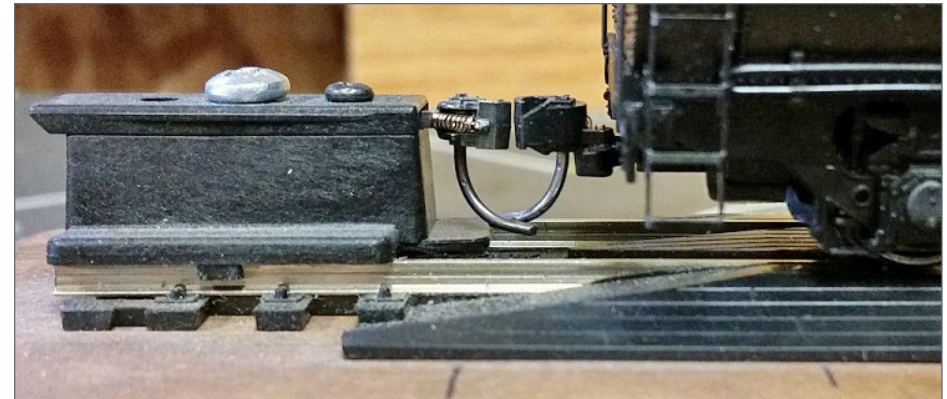

**4.** Here's the Kadee #18 coupler lined up with the Kadee #206 height gauge. You can see that the coupler has a very much underset shank. *Photo courtesy of Dave(HVT)*

**A.** Kadee recommends a #18 as a replacement. See [kadee.com/conv/hocc\\_marklin\\_trix.htm](http://kadee.com/conv/hocc_marklin_trix.htm).

This coupler has a “swallow-tail” shank that plugs into a European-standard NEM coupler socket. An alternative is to remove all of the Trix NEM hardware and attach a standard Kadee coupler pocket to the underside of the tender, after checking for the correct height.

If the coupler is sagging, first inspect the NEM mechanism to be sure it is fully seated in the underframe and the guiding pin is in its groove. Rough handling can force the coupler shank down.

**Kevin:** All of the underset shank couplers will raise coupler height about half a knuckle thickness compared to a standard Kadee coupler. If drooping is keeping it from lining up correctly, then you can place a thin shim or a wire keeper under it to help keep it aligned.

## MRH Q-A-T | 6

**Uncle Pete:** The #18 is a standard, or medium-length, shank. A #17 is shorter, and the #19 and #20 are longer. Changing the length lets you adjust the distance between the tender and the first car. If you have plenty of room to uncouple a medium, stay with it.

If you have a perfectly flat railroad with very smooth rail joints, you might get away with a coupler height mismatch. At least, it might work until your slightly low tender is coupled to a slightly high car. It's better for your operating sanity to set the height of all of the couplers to match each other.

**Dave (HVT):** I recently replaced the broken stock coupler on my Trix Big Boy with the Kadee #18 and it works great.

Follow this thread at [mrhmag.com/node/22471](http://mrhmag.com/node/22471).

## Windex and airbrushes

**Q.** Is Windex going to harm my airbrush if I use it as a clean-out solvent? I use it to clean up after shooting acrylic paint. I usually just shoot until there is no paint color, use a small brush soaked in Windex to clean the parts, and then give a good rinsing with warm tap water. I have had my airbrush for 10 years and have always cleaned it this way, but came across an article about how bad it can be, and how it can make plating lift off the airbrush. It got me to second-questioning if it was bad.

—Jeremy

**A.** Let's assume, for this discussion, that we're talking about hobby acrylics, and not about lacquers, enamels or other solvent-based paints. Let's also assume you've looked through the airbrush manual and the paint maker's website for their cleaning recommendations. Sometimes

# iwata

by ANEST IWATA

## Just Rolling By...

## Make It REAL With Iwata Climb Aboard!



Eclipse  
HP - CS

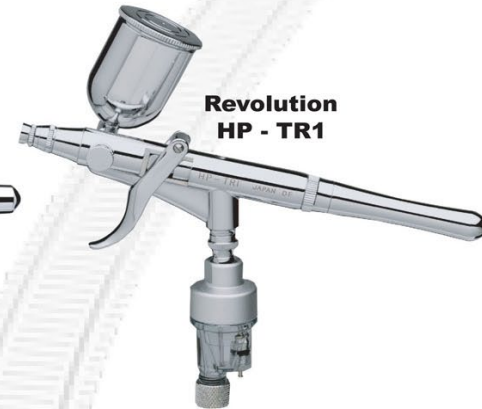

Revolution  
HP - TR1

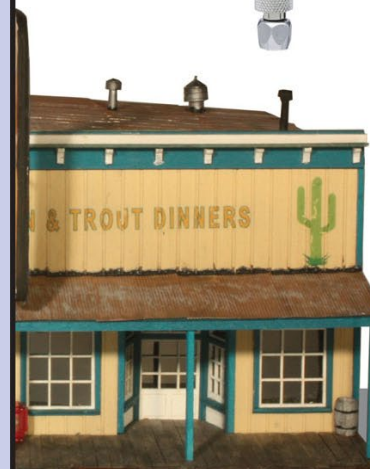

Visit...  
[www.iwata-medea.com](http://www.iwata-medea.com)  
To Check Out Our  
Full Product Line!

Models By... Alan Houtz,  
North American Prototype Modelers

July 1877?

CLICK TO KNOW MORE

Have a  
Safe & Sane  
4th of July  
Celebration  
from all of us at  
Microscale



Proudly made in the U.S.A.  
since 1933



www.microscale.com



## MRH Q-A-T | 7

when you deconstruct online advice, you find the writer is talking about a situation that's a lot different from your own.

**Hobbez:** I just use plain water as a rinse between colors, but when I do a full clean I use acetone.

[Several other people suggest using a blue windshield washer fluid containing ethylene glycol and ammonia.]

**DaveB:** Sounds like you've answered your own question. I clean mine with plenty of water but if it gets a buildup of residue, I dip it in a household cleaner with ammonia, and then rinse it out after a couple of minutes. I think Windex is pretty diluted. The ammonia cleaner I use is much stronger, so I don't leave my airbrush in there any longer than it takes to loosen any dried-on paint – usually just two or three minutes until I can scrub it off.

**JerryRGS:** My airbrush cleaning formula is:

## MRH Q-A-T | 8

5 oz. Spic & Span  
1 gallon water, 120 degrees +  
for mixing, then room temp  
for use  
2 oz. ammonia

With water-based paints which dry so fast, I place the airbrush in a container of this solution if I have any delay in painting, so the paint does not harden in the brush. After I finish painting, I completely clean the airbrush with this mixture.

**BR GP30 2300:** I use 91% alcohol between colors, and Windex when I'm done. I've had nozzles in Windex for over a year and no problems with the chrome.

**Steve in Iowa City:** Lacquer thinner is my go-to after all my acrylic or enamel painting is done for the day. I run a small amount through it before I shoot paint again, to clear out any leftover. It evaporates fairly quickly so I have time to mix paint, or position the model, or whatever.

**GN.2-6-8-0:** Check out [sites.google.com/site/donsair-brushtips](https://sites.google.com/site/donsair-brushtips) for tons of information

### Combo Right Clamp™

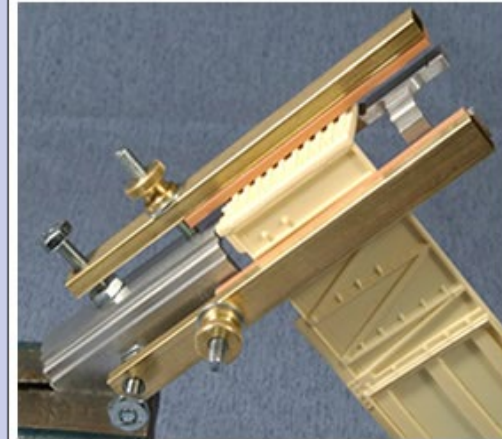

Combo Right Clamp™  
with cast resin boxcar

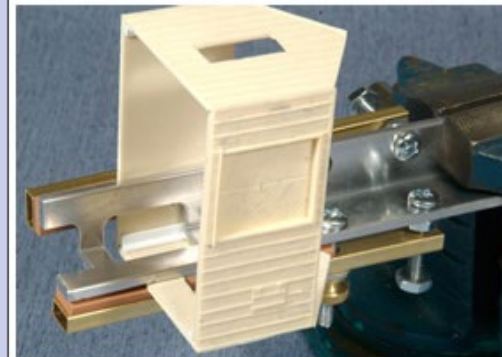

Combo Right Clamp™  
with Wolf Design Pump House

Click here for  
all our products ...

Tools for Modelers

Coffman Graphic Solutions Co.  
1500 River Circle, Richmond,  
KY 40475-7907

on airbrushes and airbrushing. Not only does it give great tips on using your airbrush, there are reviews of just about every airbrush available. Perfect for novices as well as experts.

Thanks also to Michael Watson, noahcount, and Pierre52.

If your Badger or Thayer & Chandler airbrush is badly gunked-up or broken, the company has a very quick, cheap, and efficient repair and cleaning service.

See [badgerairbrush.com/Service-Supprt.asp](http://badgerairbrush.com/Service-Supprt.asp) for details.

And: [iwata-medea.com/resources/how-to-articles/airbrush-maintenance/how-to-thoroughly-clean-an-eclipse-bcs](http://iwata-medea.com/resources/how-to-articles/airbrush-maintenance/how-to-thoroughly-clean-an-eclipse-bcs) explains succinctly what is good and what is bad to use and the reasons why.

Check for new responses to this thread at [mrhmag.com/node/22473](http://mrhmag.com/node/22473).

## TIPS

### Microbrush recycle

Don't throw away any used-up Microbrushes. If you cut off the worn-out "brush" head, the leftover handle makes a nice glue applicator for fine details. I find that the Fine and Superfine brushes work the best for this.

—Jeff Schumaker

### Truss rods

For those of you who model early equipment with truss rods, I've found that you can enlarge the openings in Grandt Line or Tichy HO cast plastic turnbuckles by using a #77 drill bit. This helps the truss rod material fit into the turnbuckle much easier.

Also, if you're old school, like me, and use thread for your truss rods, lightly coat the first ½ inch with thin CA cement. When it hardens, the tip makes the truss rod thread much easier to thread through the turnbuckles. Adjust the drill size for your scale and the size of the truss rod.

—Jeff Schumaker

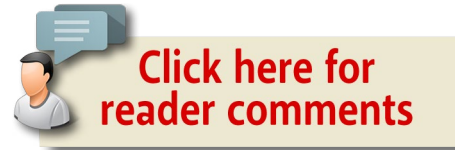

**When talking to hobby vendors, please remember to mention MRH.**

## GET PAID FOR YOUR TIP

We pay \$25 per tip we publish, or \$40 each if the tip also includes a photo or finished drawing. [Click here and select article type TIP.](#) ■

# From first train set to railroad empire...

*Our complete line of DCC products  
grows with you. Discover the fun!*

- Designed and manufactured in the U.S.A.
- Preferred for ease of use and ergonomic design
- Unlimited scalability for any size model railroad
- Plug-and-play means more time running trains
- Great customer service and excellent support



## Visit our new and improved web site for all your DCC needs!

- Get the latest new product announcements
- Watch our detailed how-to videos
- Browse the all-new Information Station
- Enjoy secure online sales, day or night!



See your dealer

Visit [ncedcc.com](http://ncedcc.com)



# TONY'S TRAIN XCHANGE

Committed to your DCC support!

Broadway Limited  
HO Scale  
EMD E Units



With Paragon2 Sound & DCC  
Starting at \$179.95

Order Yours

Broadway Limited  
HO Scale  
ALCo RSD-15



High Nose & Low Nose Units  
With Paragon2 Sound & DCC

\$199.95

Order Yours

Korea Brass HO  
GE U25C



With TCS WOWDiesel Sound  
& DCC with Keep Alive, or DC

Starting at \$169.95

Order Yours

Do you need a Sound or  
DCC Installation done?

Get a quote!

**TONY'S  
TRAIN  
XCHANGE**  
DCC SPECIALISTS

Providing unmatched person to person  
DCC support for more than 25 years, the  
kind of service that has made us #1 in DCC.  
DCC questions? CALL US! 1-800-978-3472  
\*Mention this ad for \$5.00 off your next order over \$100!

We'll get you on the right track!

July 2015



MRHMAG.COM



Model Railroad Hobbyist | July 2015 | #65

## DCC IMPULSES

column

BRUCE PETRARCA



Click here for  
reader comments

### DCC GARDEN WIRING TIPS ...

**THIS MONTH I'M GOING TO SHARE THE EXPERIENCES** I've had wiring my Rocky Mountain Pacific (RMP) garden layout ([mrdccu.com/layouts/RMP](http://mrdccu.com/layouts/RMP)). While I am using DCC, many of the issues dealt with here will affect any track-power layout in a garden and, to some extent, any DCC layout. There should be something for everybody in this column.

I'm in the desert southwest of the US. Things that work or don't work for me may or may not be part of whatever you are or need to be doing. Different climates and soil conditions can affect how one goes about garden railroading. I'm hoping that this column will trigger some discussion among folks who work in various climates. Please share what works for you. Just click on the READER COMMENTS button above, or at the end.

Long-term readers know that I don't publish what I haven't done. I've been suggesting ideas for garden railroaders, based on theory, since I owned Litchfield Station. Now I've gotten a chance to wire my own layout and can speak from personal experience. While the basic advice hasn't materially changed, I now have some tips to share.

► DCC TIPS, TRICKS, AND TECHNIQUES

- [TABLE OF CONTENTS](#)
- [INDEX](#)



### 1. My desert oasis as I'm wiring the layout in May 2015.

The basics of DCC layout wiring were covered in one of my early MRH columns ([mrhmag.com/magazine/mrh-2011-12-dec/dcc-impulses](http://mrhmag.com/magazine/mrh-2011-12-dec/dcc-impulses)). Now would be a good time for you to go back and review that column, before moving on to the special challenges of garden railroading.

### Where I'm headed

Part of the planning portion of any model railroading adventure, for many, is the "givens and druthers." I won't belabor mine here. The most important one to the subject at hand is that I want to use DCC track power on a narrow-gauge Fn3 layout. The goal of the layout is realistic freight and passenger operations, not roundy-round running. The short narrow gauge trains and the need to switch out all the cars on the train preclude any battery-car form of operation.



### 2. Here is the RMP Shay dreaming of running above Telluride.

ADVERTISEMENT

**IOWA SCALED  
ENGINEERING**

Master clock

8:26 AM  
7:23:36PM  
REAL HOLD RST CONF

Remote clock

8:26

Easiest-to-use, most advanced  
fast clock on the market

LEARN MORE >

From prior layouts, I had enough brass track for my new version, so that is what I'm using. To achieve adequate performance with the brass track, I plan to experiment with some form of hybrid-drive, where the track power trickle-charges a small onboard battery to sustain motion over dropouts of track power. This is Stayin' Alive ([mrhmag.com/magazine/mrh-2013-03-mar/di\\_staying-alive](http://mrhmag.com/magazine/mrh-2013-03-mar/di_staying-alive)) on steroids. Perhaps I'll do a future column on this concept.



### Setting the standard(s)

Whether one realizes it or not, layouts are built to standards. They may be rigid and formal, or not. I find that more formal standards tend to make for more consistent results.

I wrote down a set of electrical standards as I began the layout. Along the way, I modified the written standards. I'm not saying that everything on the layout completely complies with the final written standards, but the layout is more consistent than it would have been absent a written goal.

Here's what I have for standards as I'm finishing up the wiring:

1. All connections to the bus are soldered.
2. All connections to the track include a soldered terminal, stainless steel screw and star washer and are coated with anti-corrosion fluid, such as Never Stall.
3. All power districts are protected with electronic circuit breakers.
4. All rail joiners are Split Jaw clamps, and the electrical interface is covered with anti-oxidant grease, such as Ox-Guard.
5. Every piece of track will connect to the bus at one end or the other, using the Split Jaw rail clamp screws.
6. Where the track connects in a loop, the bus will not close the loop, but will be open at the far end of the loop.
7. Wiring size conforms to table [3] for maximum length of run vs. AWG
8. All gaps are offset rail-to-rail a few inches or more.
9. The yard will be fed by two separate buses (one for each pair of tracks), connecting to the main bus near the yard throat.

### Bus design

I'll be using an NCE 10-amp radio system. The layout is divided into three districts: the inner loop, the outer loop and a

AWG gauge	Maximum Length feet
12	50
14	31.45
16	19.77
18	12.44
20	7.82

### 3. Recommended maximum DCC bus length vs. AWG.

plug into a socket slightly above ground level.

A dummy plug inserted into the socket will keep it clean and dry when the barn is not in place. The barn can be brought inside, along with the other DCC electronics, when not in use. The dummy plug will connect all three track buses to the booster, so that trains

combined wye and teardrop reversing section. Per standard 3 above, the booster will feed two PSx circuit breakers and one PSxAR combined auto reverser and circuit breaker.

These electronic modules will be inside a scale model barn [4]. The structure (CMS3012 – Whitlows Barn – \$39.95) is a Colorado Model Structures kit ([coloradomodel.com](http://coloradomodel.com)).

I added a plywood floor for the loft, and the electronics will mount there. Using an 8-pin Cinch Jones connector, the barn will

## DCC IMPULSES | 6

can be run on most of the layout without the barn in place. The limitation is to stay off the green wye area. The green part of the outside loop is fine, just not the teardrop.

The electrical block diagram is shown in [5]. There are three buses radiating out from the barn, as shown in [6].

The auto-reversing (green) bus covers the middle left section of the layout and breaks the outer loop into two convenient sections.

The outer loop (red) bus runs clockwise a short distance from the barn and then counter-clockwise for the rest of the outer loop.

A (blue) bus comes from the barn directly to the inner loop, where it splits. Each side goes half way around the loop, with no

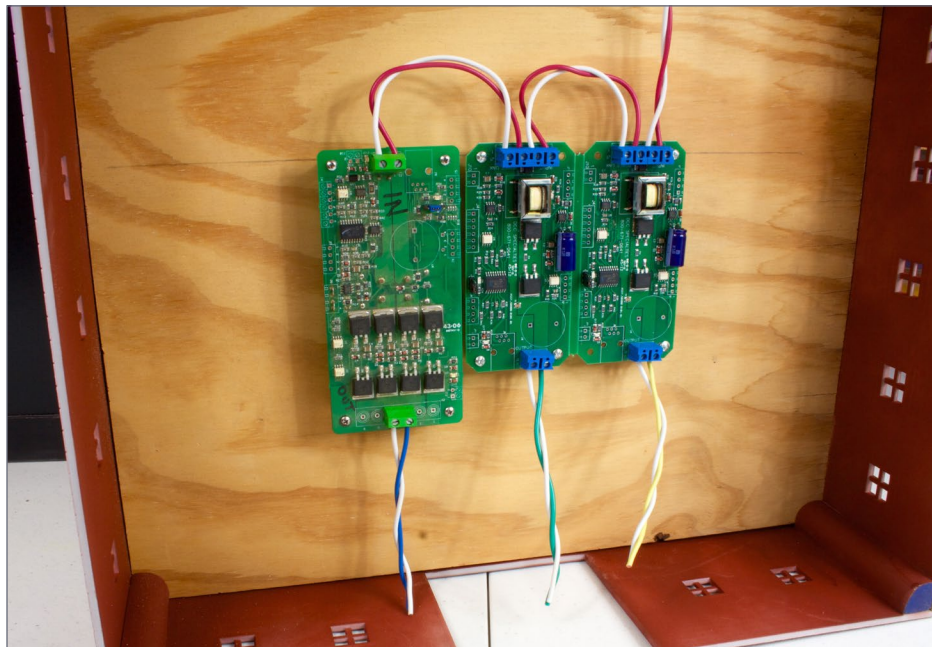

4. Electronics in a barn viewed from the bottom – wires are just for testing and do not conform to the color codes used in this column – an 8-pin connector will be added.

## DCC IMPULSES | 7

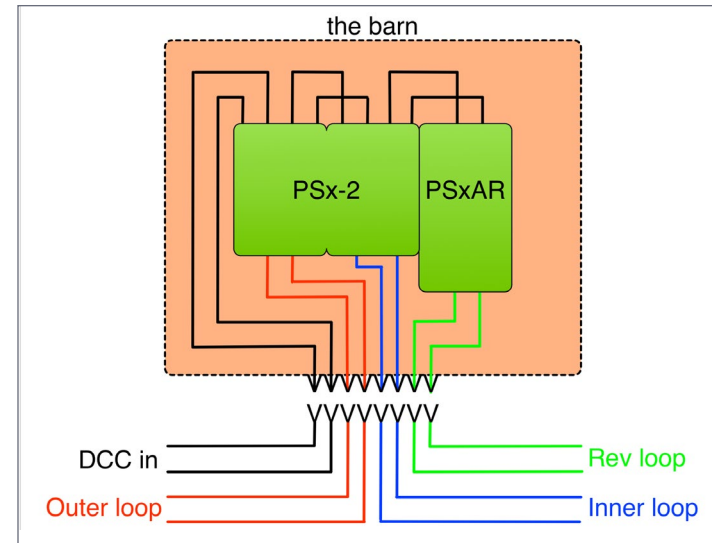

5. Block diagram of RMP wiring.

ADVERTISEMENT

## Have You Heard?

The Tsunami SoundCar provides over **20 sound effects** for rolling stock!  
Stop running silent trains.

Hear what your train *could* sound like!

**SOUNDTRAXX**



- [TABLE OF CONTENTS](#)
- [INDEX](#)

## DCC IMPULSES | 8

connection on the far side. The buses that feed the yard break off the loop bus and follow the yard.

### Gaps

One of the keys to multiple DCC districts is effective and reliable gaps in both rails. With the expansion and contraction in the garden, keeping these gaps is more difficult than it is inside. Here in Arizona, we see track temperature running from just below freezing in winter to 160° F+ (72° C+) in summer.

I used the ugly yellow LGB insulators, as they meet the physical requirements that I want. They will be painted with flat brown Krylon paint when I'm done with the wiring and testing. I've

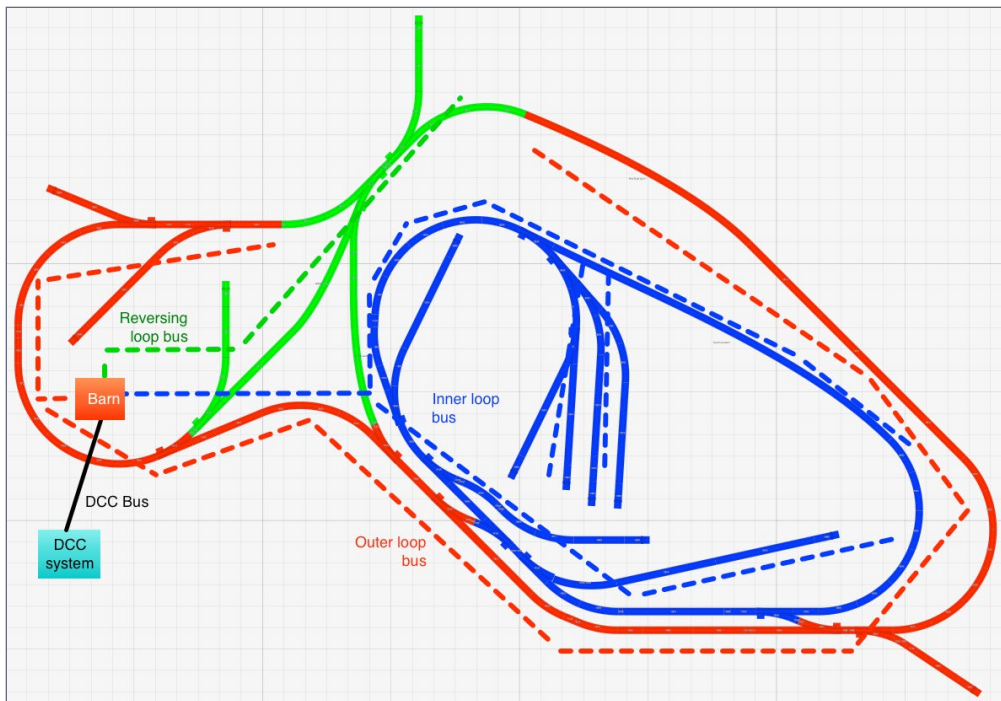

6. RMP track plan, showing the three buses (dashed lines) emanating from the barn and DCC feed (black) coming into barn.

ADVERTISEMENT

# FUN FUN FUN

## In the Summer!

# Litchfield

## S T A T I O N

623-298-7355 • [www.Mr-DCC.com](http://www.Mr-DCC.com)  
[www.LitchfieldStation.com](http://www.LitchfieldStation.com)

used Earth Brown Krylon Camouflage Paint on my track to cut down the bright brass look and make the ties from several vendors the same color.

All gaps are offset rail-to-rail. Some by a few inches, some by a foot or more.



**7. Rail gaps on the RMP before painting the yellow joiners. Note: black plastic strip screwed to ties to hold gaps together. Note, also: black feed wires connected to Split Jaw clamp with stainless steel socket head screws.**

### Track wiring

I installed the track and began testing two years ago. During the intervening time, I've been running each of the three sections of the layout with only one feed point. Yes, some areas started having issues as the rail joints began to weather. But it did run okay with one feed per district for a while.

Now, in the final wiring, I'm going for bulletproof. The goal is to have every piece of track connected to a bus. I admit there are some sections (usually under six inches long) that don't get fed from the bus and rely on power feed from adjoining sections. If they act up, I'll add a power drop to them.

This doesn't mean that I connect the bus to every clamp, just every other one. The rails to both the right and left of the clamp get fed from that clamp.

I'm using high-conductivity brass track that has a cross-sectional area larger than most DCC bus wire. Why the need for so many drops? Well, what the track gives, the rail joiners take away. They only clamp the sides of the rail base. The greatest area of common connection is between the clamp and the bottom of the rail base. This is an area where moisture, corrosion and salts can accumulate, none of which are good for electrical conductivity. Opening up the clamps to add a power drop shows a pretty badly oxidized connection after two years outside.

So, I added a standard (#4) to do the joints differently. Now, in addition to polishing the areas of contact between the rail clamp and the track before assembly, I'm coating the mating surfaces with Ox-Guard. This product is available at home improvement stores, hardware stores and online at Amazon ([amazon.com/dp/B000BODU66](https://www.amazon.com/dp/B000BODU66)). This specific part number is a Gardner Bender product designed for electrical connections where aluminum and copper wire meet. My goal is to keep water and salts out of the joint, while keeping it conductive.

## DCC IMPULSES | 11

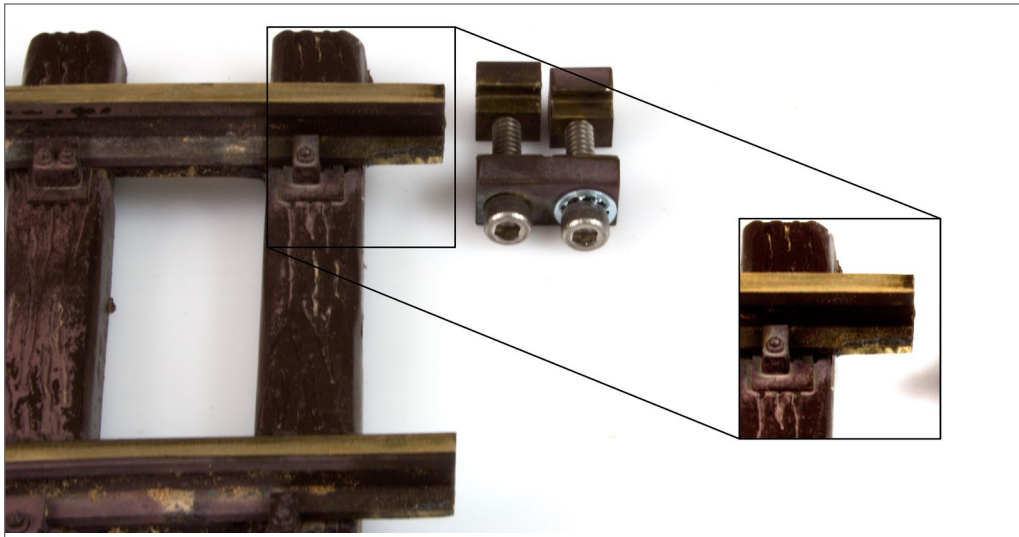

8. Weathered rail and clamp surfaces after two years in the desert garden. Note in the inset: the small area where the rail clamp keeps the base of the rail clean. That, plus the bottom of the rail, is all that conducts across clamps.

For feeders less than a foot long, 18 AWG wire is perfectly acceptable, per table [3]. Black lamp cord from the home improvement store is what I used. I used ring terminals designed for this wire gauge. The red sleeve is used to identify them in the US. They fit nicely under the 6-32 machine screws on the Split Jaw clamps. I removed the red sleeve by gently pulling on it before I soldered the wire. This makes for fewer colors to hide on the layout. I cut the lamp cord to one-foot-long sections and soldered the terminals to them [10] on the workbench – so much more comfortable than working on the ground outside. I did not crimp the connections.

Now for the connection to the track. I like the Split Jaw ([rail-clamp.com](http://rail-clamp.com)) clamps, but find that the steel screws supplied with them bend when I apply the amount of clamping force I desire.

## Get Better Sound from your Locomotives

Can't get a good sound from your sound decoder?  
Give our speakers a test drive with your ears.



**RAILMASTER HOBBIES**  
**9812 BELMONT**  
**BELLFLOWER, CA 90706**

Bass Reflex  
Speakers



High Bass  
Speakers



When it comes to speakers we have high quality speakers to fit many different applications. We are also a full line hobby shop. Need anything? We are an authorized dealer for Soundtraxx, Digitrax, Athearn, Walthers and many others. We provide quality speakers for your DCC sound systems and quality service.

**Click here for  
the answer ...**

## DCC IMPULSES | 12

So, I replace the screws with 6-32 x 5/8 inch stainless steel socket head machine screws (SCS0610) from MicroFasteners ([microfasteners.com](http://microfasteners.com)). I also use a #6 internal tooth lock washer (MicroFasteners LWT06) between the ring terminal and the Split Jaw clamp. This lock washer bites into each side a bit and helps with conductivity. I build the assembly [11] and use a toothpick to spread the Ox-Guard on the mating surfaces. I apply Never-Stall to the area in the connection where the brass clamp, stainless screw and plated steel lock washer meet

Connect the feeder wire to the track by installing the clamp [11] to join two sections of rail together.

### Bus wire



9. Gardner Bender Ox-Guard one ounce tube. Photo from Amazon

From table [3], 12 AWG wire was selected for my bus runs, as they are all less than 50 feet. Larger layouts may require larger wire: 10 AWG, or even 8 AWG. Home improvement stores sell double stranded “landscape lighting wire” in several appropriate sizes. This is designed to be buried and to carry high amperage at low voltage (30 volts or less), just like track power, DCC or DC. It has very thick black insulation and is resistant to chafing.

I do not recommend solid wire in the garden. The landscaping wire is stiff enough as-is. Solid wire will be a bigger challenge to keep buried.

## DCC IMPULSES | 13



10. Ring terminals for 18 to 22 AWG wire (red sleeve removed) soldered to foot-long 18 AWG drop wires.

Splitting the two-wire cable allows for room to strip each wire a bit apart from the other. I use the end cutter pliers (black handle in the center of [13]) to start the split. Then I use the wire strippers to cut through the insulation. Then I use a set of fine cutters to remove the insulation, being careful not to nick any of the strands of wire.

The bus is tinned before the drop wire is wound several times around the bus wire and soldered [12].

### Insulation

I don't insulate my joints. I just bury them. Remember, I live in the desert, and the first few inches of unirrigated soil is pretty dry most of the time. There may be a day or two where the electrical leakage through the soil might keep me from running. However, my garden will not be fun to walk in when the soil is that wet, anyway.

So this is one place where I cannot recommend other options from personal experience. If I were in almost any other climate, I'd be looking for a way to insulate the joints. Perhaps a liquid electrical tape or some conductive grease filled shrink tubing. Ideas, anyone?

# DCC IMPULSES | 14

## Tools

As in all endeavors, tools and supplies [13] are what make the job easy. I use wire strippers that have specific sections sized by wire gauge. For this sort of wiring, ones that cover 10 AWG solid to 22 AWG stranded fill the bill nicely. The Tekton 3797 ([amazon.com/dp/B00AZWWY2K](https://www.amazon.com/dp/B00AZWWY2K)) is similar to what I used.

K & S Engineering makes two inexpensive soldering irons in the \$10 range. I tried to use one to save carrying my soldering station outside. The result was a bunch of cold solder joints. To remedy the situation, I brought my (expensive) Weller WTCP51 60-watt thermostatic soldering station with a broad tip rated at 800°F (PTD8) outside. Much better results followed.

The slightest breeze will suck heat away from the joint. So, an abundance of heat is needed and perhaps, a windscreen to reduce breezes. Don't even try to solder in cold or very windy conditions.

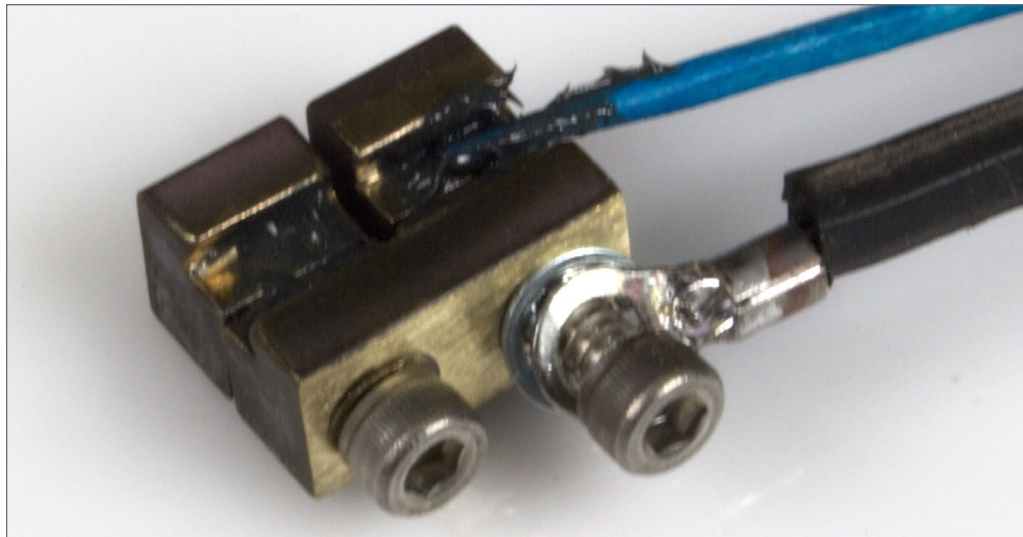

11. Connection of the feed wire to the Split Jaw rail clamp. Ox-Guard has been applied to the mating surfaces with the blue toothpick, shown.

ADVERTISEMENT

Make LocoNet wiring extremely simple!

**ACCU-LITES, inc**  
Your DCC Center!

CELEBRATING 20 YEARS ANNIVERSARY Dealer Inquiries Accepted

PM42 breakout board

BDL168 Multi-zone breakout board

SE8C breakout board

BDL168 Single-zone breakout board

Now Offering SNAPS! in packs of 6 or 12 pieces! [CLICK TO LEARN MORE ...](#)

ADVERTISEMENT

Touch Toggles™ + Toggle Cups

Perfect

Twin Coil  
Tortoise – Stall  
Servo  
Power Control

**BERRETT HILL TRAINS**

Made in the USA

What will they think of next? [www.berrethillshop.com](http://www.berrethillshop.com)

# DCC IMPULSES | 15

To clean the weathered track base and Split Jaw clamps, I use a wire brush. The most convenient is a Dremel 535 brass wheel brush in my battery-powered rotary tool. I tried an inexpensive similar looking unit. It came in a pack with four other brass brushes from an online discount tool store. They rate their product for 2500 RPM maximum. I found out why. Even as slowly as my tool could go, the vibration was horrendous. They don't seem to care about balancing the wheel, and the stress on the bearings was unbelievable. Stick with the good wheel here. Actually, they are a consumable. I used up several wiring the layout this time, part of the reason for the try at the less expensive version. Use safety glasses, as the little brass wires come out of the tool, and there is debris coming off the track and clamps.

## Soldering

The intent here is not to teach you how to solder, but point out some issues that arise when working outside on large wires. A web search brought up a website that has a pretty good tutorial,



12. Connection between drop wires and bus wire. Two joints are shown in the photo. In the upper right is a completely soldered one – note the bright and smooth surface, indicating that enough heat has

been used. In the lower left, is a drop wrapped around the tinned bus, ready for soldering.

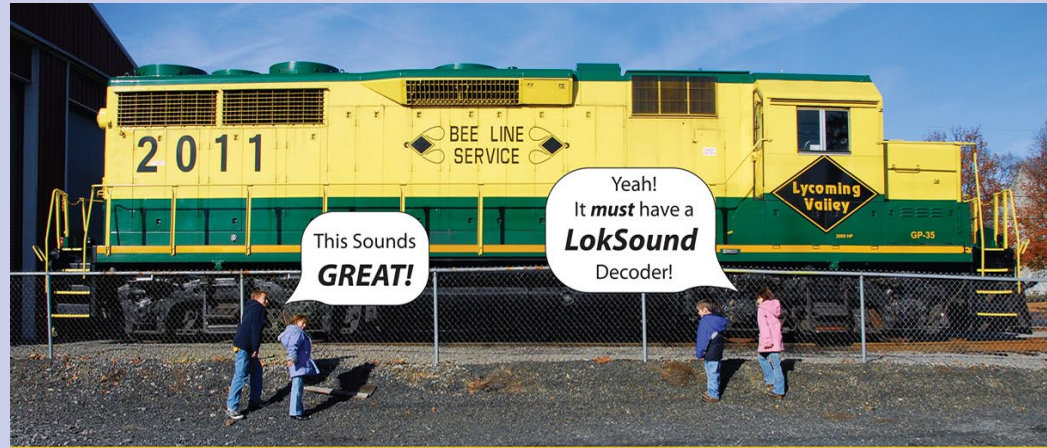

**SO REAL...You'll Think You're There!**  
**LokSound Select · 3 SIZES, ENDLESS POSSIBILITIES!**

**INDUSTRY LEADING MOTOR CONTROL**

- Multiple Bell types
- Multiple Brake squeals

**4 OR 8 Ohm SPEAKERS!**

- 4 or 6 Output functions depending on the style  
 - Up to 4 Prime Movers or Steam Sounds on EACH decoder  
 - 16 Very Playable, LOUD Horns or Whistles depending on Profile  
 - All Changeable by using ONE CV! No Programmers or Boosters needed!\*

Small Size  
**BIG POWER! 1.1Amp!**  
LokSound Select  
**"4 AUX"**



\$99.99

**NEW 2011**

Only Available From ESU LLC (USA)

**ONE SIZE FITS ALL!**  
LokSound Select **"DIRECT"**



\$109.99

**NEW 2011**

**6 Outputs!**  
LED Resistance Built In!  
**LOK SOUND SELECT**

Only Available From ESU LLC (USA)

Tiny Size,  
**HUGE Versatility!**  
LokSound Select  
**"MICRO"**



\$99.99

**NEW 2011**

Only Available From ESU LLC (USA)

\* ESU LokProgrammer needed to "Replace" Sound and for Firmware updates, not for normal editing

www.LokSound.com • 477 Knopp Drive Muncy, PA • 570-649-5048      Now on facebook! 



## DCC IMPULSES | 16

including some videos: [aaroncake.net/electronics/solder.htm](http://aaroncake.net/electronics/solder.htm). There are a myriad of them out there, so you can find one that speaks to you.

It is essential to use products designed for electronics: rosin core solder and rosin flux. Plumbing products such as wire solder and acid paste are a no-no. The recent financial trouble at Radio Shack has removed many local sources for products aimed at electronics. There are always online sellers.

Folks who follow my column know that I eschew solder flux. But you see some flux with my materials [13]. The garden is one place where I keep it at hand. Once wires spend some time in the weather or in the ground, they tend to oxidize even inside the insulation. There is not enough flux in normal solder to overcome the oxidation. So, when I cut into the insulation and find that the wire is



13. Some of my tools and supplies for wiring in the garden, spread out on a cheap white towel to keep them clean and help me find them in the dirt of the garden.

## DCC IMPULSES | 17

black, I apply flux and tin the wire before I move on. It may take an excess of solder to penetrate the oxidized section and get the solder to flow into the strands. Be sure to shake the excess solder off while it is molten.

Key to reliable wiring is having a good mechanical joint before soldering. The smaller drop wire can be wrapped a few times around the bus wire. For a splice in a bus wire, stagger the joints [14] and make a butt splice. To make a good mechanical joint, wrap a bit of solid wire (18 AWG or so) around the overlapped, tinned wires and solder.

Sharp eyes will see a buzzer and a bit of track amongst my tools [13]. This brings up the issue of color coding. While I promote color coding for indoor layouts, I don't suggest it in the garden. Rather than trying to keep wires straight, I fall back on my buzzer. I put the buzzer across the bus and wire the track.

Once the first drop is wired, the bit of rail can be placed across the track to make sure

YD  
Yankee Dabbler.Com

# Get The Best!



# Click NOW!

(while supplies last)

HO

DCC

ALL SCALES

- Kadee - NCE - SoundTraxx  
- Digitrax - And more!

## DCC IMPULSES | 18

the buzzer is connected and functional. With following drops, a quick touch to the bus wire will tell you if you have the correct one (no buzz) or the wrong one (buzzer sounds off).

My final comment comes into play when you are grading the track. How to hide the bus wires. Where the track is raised off the ground, I stuff the bus wire under the track and cover it with the sub roadbed and ballast. Where it runs across open ground, it can be an issue. Here in Arizona, we have very dusty soil – when it is dry. When it gets wet, it tends to set up like concrete. So, I use the garden trowel (or spade for long distances) to open up a ditch. I maneuver the bus wire into the ditch. However, if it is just covered up, it tends to just jump back out. To keep the wire in place, I use the staples designed to hold down cloth and other under-layments, [15]. Landscape stores sell them. A bit of dirt over the top, and we are ready for the next rain to solidify the soil.

Lots of fun stuff to cover this month. Folks always seem to have more ideas to share. Just click on the Reader Feedback icon at the beginning or end of the column. While you are there, I encourage you to rate the column. “Awesome” is always appreciated. Thanks.



14. Butt splice in bus wire. Lower left has been wrapped with smaller solid wire and soldered. The

ends of the smaller wire will be trimmed. The upper right one is wrapped, ready for soldering.

## DCC IMPULSES | 19



15. Secure the bus in the ground with landscaping staples – this sequence shows the wire going from lying in the ground to buried.

ADVERTISEMENT



**TamValleyDepot.com**  
Great Electronics for Great Model Railroads

We are loading up the boxcars with Frog Juicers ready for your layout!

ADVERTISEMENT



**GLX**  
TOP QUALITY PRODUCTS  
FOR THE MODEL RAILROAD CRAFTSMAN  
[WWW.GLXSCALEMODELS.COM](http://WWW.GLXSCALEMODELS.COM)

**Sugar Cube Speaker**

Click to Order

# DCC IMPULSES | 20

Until next month, I wish you green boards in all your endeavors. ☑



**Click here for reader comments**

ADVERTISEMENT



Installing DCC sound just **NOT** your thing?  
Trust Traintek for sales and installation of sound decoders from these fine vendors!



"Taking model railroad control to the next level..."



**traintekllc.com** "Traintek was the way to go!"  
Click here for more details...

ADVERTISEMENT

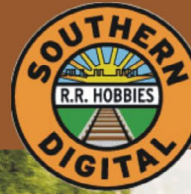

# Southern Digital



**20% Discount on most items!**

*Specializing in DCC Since 1992*

ADVERTISEMENT

**RailPro™**  
**NEW TECHNOLOGY**



**RE RING™**  
ENGINEERING

**NEW Starter Kit \$399.99 MSRP**

- Includes Wireless Color Touch Screen Handheld Controller and 56 Watt Power Supply
- Expandable to Virtually any Size Layout

**NEW Locomotive Module**

LM-2 & LM-2S

- Direct Radio RF
- Sound and Non-Sound
- New Tiny Size
- 6 Light Outputs



**Click Here to Learn More**

For more information visit our Internet site: [www.RingEngineering.com](http://www.RingEngineering.com)



**DCC Conversions, Service & Support**

Orders Received by 3:00 pm EST ship the same day

**WWW.SODIGI.COM**

E-mail: [sales@sodigi.com](mailto:sales@sodigi.com)

(770) 929-1888

*(Photo's are from our N-Scale layout)*

# TMTV *HOT* Summer Sale!



Coming to TMTV soon ...

- Double the how-to clinics!
- More free eBooks
- George Sellios' F&SM update
- Joe Fugate's Siskiyou Line updates
- More Mike Confalone how-to's
- New series: Back to the workbench

1-year membership: ~~\$59.77~~ **\$48**

2-year membership: ~~\$95.77~~ **\$72**

3-year membership: ~~\$107.77~~ **\$99**



Or try our new  
**TURBO membership!**

**\$29.95** gets you six months  
unlimited access



Sign up to win a free tablet -  
no purchase necessary

Become a  
TMTV member >>



Model Railroad Hobbyist | July 2015 | #65

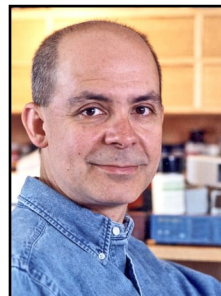

MIKE ROSE  
.....

## GETTING REAL

column



[Click here for  
reader comments](#)

### FINISHING AN ENTIRE AISLE OF LAYOUT PART 1 | COULD I "DECLARE VICTORY" IN THE DEFINED-WORK WINDOW?

**THE OLD SAYING "TIME FLIES WHEN** you're having fun" is nowhere more appropriate for me than when I'm working on my model railroad. Some of the happiest chunks of time occur when I get in the flow, know what I want to do, know how to do it, and put on some music and do just that. This article will cover what was accomplished in the latest "defined-work window," and how I did it.

Of course, "defined-work window" sounds kind of like corporate-speak, but what I really mean by that term is the period between scheduled op sessions, minus the obligatory minimum two weeks prior, to clean up and test, plus stage the session. I had told my ops friends that I would start the next stage of construction immediately after the next session's conclusion, and

► MODELING REAL RAILROADS AND WHAT THEY DO

that was exactly what happened. The session was on January 10th, a Saturday, and on Sunday the 11th I began removing cars and preparing for the work that would commence on Monday.

My last “Getting Real” column in Issue #60, February 2015 detailed the work involved in finishing up one whole side and end of a peninsula. The success in achieving that caused me to focus on the opposite side of that same aisle, which was the last remaining large, unfinished area of the layout. The goal: to be all done with “making a mess” in that room, which for me meant all foam installed and carved, backdrop trees in place, ground cover down, roads, a river scene including abutments, and maybe even a little structure mockup. The work window was mid-January to mid-March, and I was hoping to achieve that goal in that approximately eight-week time period.

Anyone who lived through the Winter of 2015 in New England knows that it snowed – a lot! In fact, there was a two-week stretch where it snowed about every three days or so, causing me to spend a great deal of time plowing. Couple that with some IT work that I still do, plus the layout work, and I was a pretty busy guy during this period. It was a tough winter, even by New England standards, but fortunately I spent much of it (when not plowing or working) in my basement where it’s always sunny in Pennsylvania!

### How to begin?

As usual, the initial difficulty is always “how do I begin?” For me it had to start with an important backdrop photo that would allow Masonite Rd. to “escape” the layout and give a relatively shallow scene some much-needed depth. I had taken a good bunch of road shots the last time I’d traveled to my modeling area, and after discussing them with Mike Confalone, he agreed that one in particular would have the proper aspects he needed to properly Photoshop it to fit the scene, to scale.

ADVERTISEMENT

## Railroad Explorer Magazine

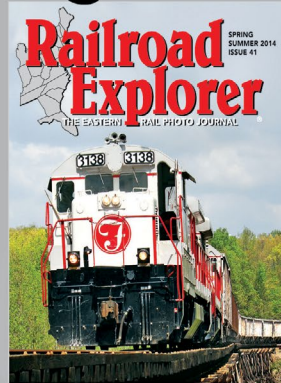
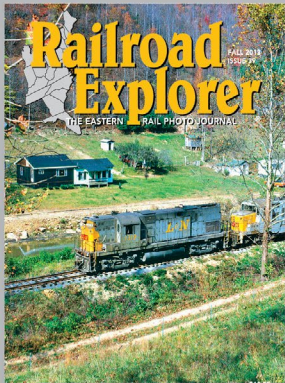

THE EASTERN RAIL PHOTO JOURNAL

- Three all-color issues per year. Exciting feature stories and spectacular photos of Eastern Railroading
- Best-in-class photo reproduction. Printed on heavy, glossy paper. Zero advertising.
- Three times per year - Winter, Spring/Summer and Fall editions.

**Subscribe today!**

[www.railroadexplorer.com](http://www.railroadexplorer.com)

Want to help  
keep MRH free?  
Then click on  
Ads!

## GETTING REAL | 4

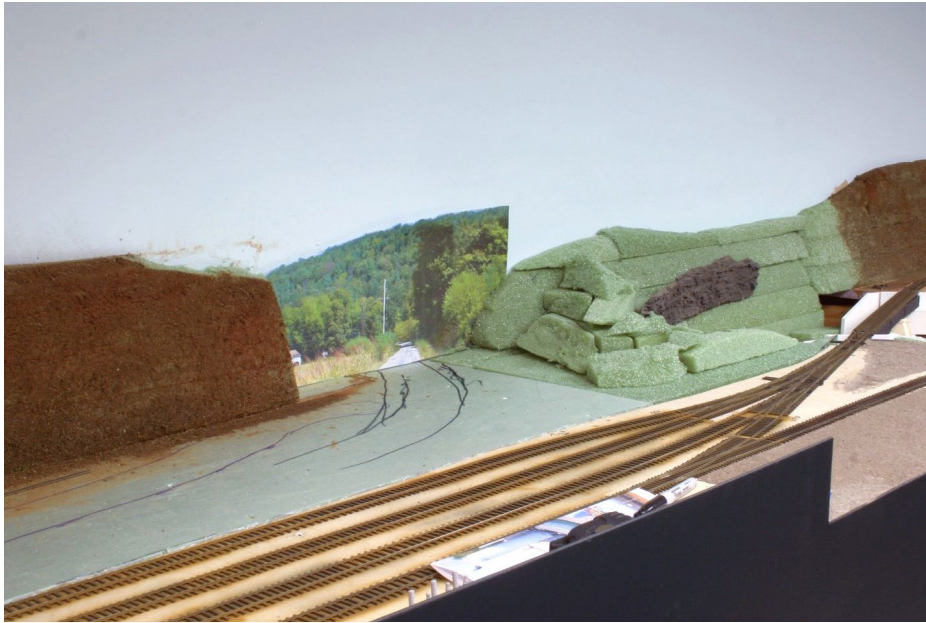

1. In this photo you can see how I've printed the Photo-shopped photo onto regular paper, taped it together, and am using it to compose the scene. This was a very tricky area to get right for me, as the overall scene had to do several things. First, I needed to get a road coming from the left, off the layout to the rear, into the photo. The foam scenery to the right of the road needed to obscure the disappearing road when you were standing off to the right and viewing the bridge scene, barely visible to the extreme upper right. And by the same token, when standing here, it had to focus attention on what was in front of the viewer, and separate the yard scene from what was happening at the river and beyond.

## GETTING REAL | 5



2. Here's the opposite view. Already I'm mocking-up the foam to try to picture the final contours needed to create a treed "lump" that will obscure the road, but look right from this angle. Note how the river banks have already begun to be formed-up, so it's mainly what's happening behind the bridge that is still in flux at this point. That's a Cripplebush shale rock casting being tested in place against the foam.

## GETTING REAL | 6



3. At this stage some of the foam pieces have now been carved, but not glued in place. While I do final carving of the foam once it's firmly glued down, I find that for some of the carving, it's easier to shape an individual piece and then put it down on the layout for final tweaking.

## GETTING REAL | 7



4. I was highly motivated to use up as much of the leftover foam as possible! Since there were to be so many carved shapes anyway, this was an efficient use of the pieces, rather than chop up large fresh pieces. So although it looks like just a jumble of random shapes loosely piled in the foreground, there's a method to my madness.

33,000 have seen this MRH video - *have you?*



Watch the  
video now



When talking to hobby  
vendors, please remember  
to mention MRH.



5. Now it's time to apply hot glue and get much of this foam fastened in place for final carving. The incredible Pamtite hot glue gun is prominently featured here, and with that color you can't miss it, which is a plus when you're looking for it! Note about the fillet knife that I use to cut some of the foam. I frequently sharpen it, since foam can be very dulling when cutting it. Multiple glue sticks are ready at hand to the right. You tend to use a lot of the hot glue, and there's nothing worse than running out of it right in the middle of a long piece you are putting down. It dries fairly rapidly, so you want to be able to load another glue stick right into the gun and keep on moving with it. The Pamtite is normally used to apply an extremely strong bonding stick at very high temperature, but I dial it way down and use standard glue sticks for foam work. Otherwise it would melt right into the foam.



6. Here you see that many of the foam pieces have been glued down, and also that I'm using old lead weights, leftover scenic material (even rice!), and plastic bottles filled with water as weights. You don't need to weigh it down very long, because in just a few minutes it's holding firmly. Weighting is mostly useful when you need to flex or otherwise persuade a piece of the foam into place. Plus, it beats standing there and holding it for a few minutes ...





7. This photo shows the overall completed foam-scape with all basic carving done, shown from one of the important viewing perspectives. Note that only one bridge abutment has been test-colored, not all bridge girders are glued on, and the foam particles all over everywhere. This is part of what I mean about being done making a mess in this aisle!

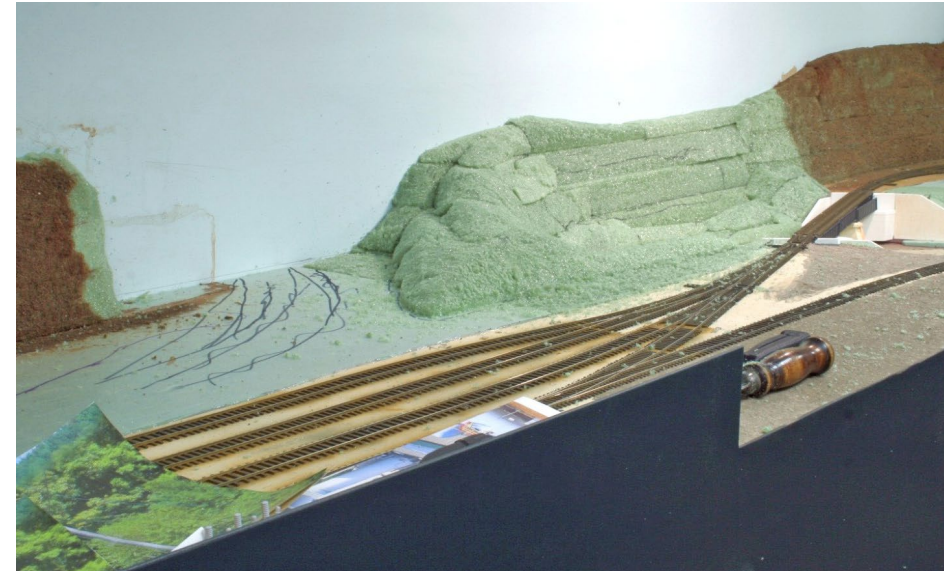

8. For comparison, here's the opposite angle view, this time from the yard/road viewing perspective. You can immediately see how this scene is nothing without even the crude backdrop photo, but stay tuned for the evolution of this view in particular.

ADVERTISEMENT

## TRINITY 3281



CMO - 12 road numbers \$48.95 each



CSX - 12 road numbers \$48.95 each



TILX - 6 road numbers \$48.95 each



WSOX - 6 road numbers \$48.95 each  
plus CRDX and MCEX

**American Limited**

www.americanlimitedmodels.com

ADVERTISEMENT

## George's Trains

EST. 1962

Canada's Greatest Model Train Store!

# PROTO-PAINT

20 NEW Colours Just added!



**ACRYLIC - Air Brush Ready**  
NOW OVER 45 Canadian Railway Colours!

Dealer inquiries welcome.

PP-001 CNR Green #11	PP-020 TH&B Maroon	PP-038 TTC CREAM
PP-002 CNR Imitation Gold	PP-021 Primer	PP-039 TTC Maroon
PP-003 CNVIA Blue #16	PP-022 Reducer	PP-040 Warm BLACK
PP-004 CNVIA Yellow #18	PP-023 Flat Finish	PP-041 Grimy BLACK
PP-005 VIA Grey	PP-024 Stencil White	PP-042 Anti-Glare Black
PP-006 CN Red/Orange #11	PP-025 Loco Black	PP-043 Slag Brown
PP-007 CN Lettering Grey #17	PP-026 Flat Haze	PP-044 GO Green
PP-008 CN Grey #11	PP-027 ONR LT BLUE	PP-045 GO White
PP-009 CNR Red #12	PP-028 ONR DK BLUE	PP-046 CONRAIL Blue
PP-010 CPR Tuscan	PP-029 ONR YELLOW	
PP-011 CPR Diesel Grey	PP-030 ONR Post 2000 Yellow	
PP-012 CPR Diesel Yellow	PP-031 ONR GREEN	
PP-013 CPR Steam Grey	PP-032 BCR/PGE DK GREEN	
PP-014 CPR Mineral Brown	PP-033 BCR RED	
PP-015 CP Action Red	PP-034 BCR Blue	
PP-016 CP Action Yellow	PP-035 BCR Yellow	
PP-017 CP Action Green	PP-036 BCR/PGE LL GREEN	
PP-018 CP Bright Red	PP-037 GTW Blue	
PP-019 TH&B Cream		

**ORDER NOW!**

530 Alden Rd. Unit 101 Markham, On, Canada L3R 6A8  
Tel: 905-470-6200 Toll Free: 1-877-8TRAINS (887-2467)  
www.georgetrains.com

\$8.98 each  
Canadian



9. Since I'm telling this story in chronological order, here's a shot of something on the other side of the same aisle I was working on at the same time, in keeping with the mess-making theme of the activity. You can see how the hillside has been carved away to provide sufficient space for the twin silos that need to be there, along with a shed building. These are the silos from the incomplete Laceyville Agway, shown here at the Wyalusing Purina, to make sure I get the proportions right. The mockup of the mill was done off of a prototype photo shown in my last column, done entirely from a piece of legal pad backing cardboard and painted to represent the prototype. With the foam carved and shop-vac cleanup complete, it was time to figure out the concrete retaining walls needed here.

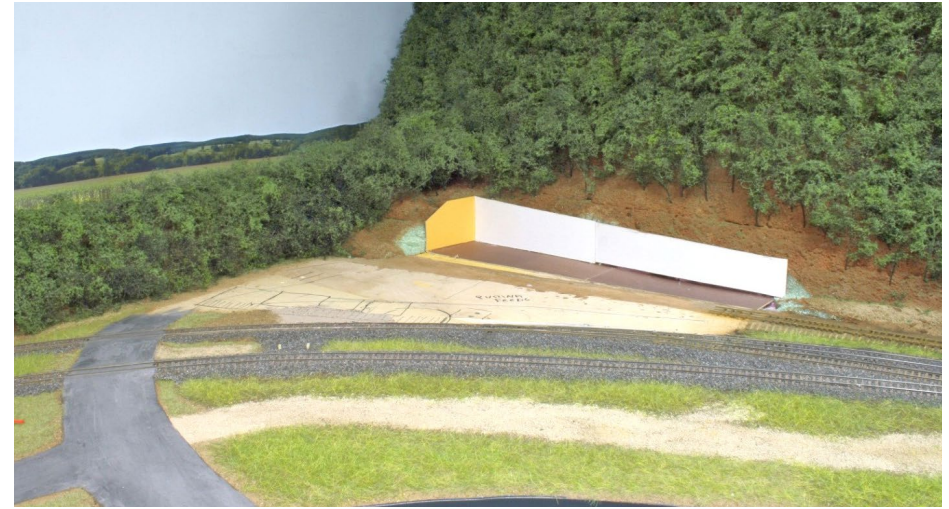

10. I used heavy cardstock to fill in the ground and retaining areas, and cover up the ugly pink foam underlayment visible after carving. Immediately the site began to look better to me.

ADVERTISEMENT

**ONE STOP SHOP**

**N, HO, O, ON30, S & G**



**SHOP ON-LINE 24/7**

**FOR YOUR FAVORITE PRODUCTS:**

ATHEARN | ATLAS | ARISTO-CRAFT | BACHMANN | BROADWAY LTD.  
 DIGITRAX | KADEE | KATO | K-LINE | LIFE-LIKE | LGB  
 LIONEL | MANTUA | MICROTRAINS | MODEL POWER | MRC  
 MTH | NCE | PECO | PIKO | SOUND TRAXX | TCS  
 WALTHERS | WILLIAMS | WOODLAND SCENICS | AND MORE...

**SIGN-UP FOR OUR E-MAIL SALES**

**TRAINWORLD.COM**

**1-800-541-7010 e-mail: [ORDERS@TRAINWORLD.COM](mailto:ORDERS@TRAINWORLD.COM)**

**TRAINWORLD®/TRAINLAND® - AMERICA'S LARGEST INTERNATIONAL MAIL ORDER DISCOUNT TRAIN STORE**

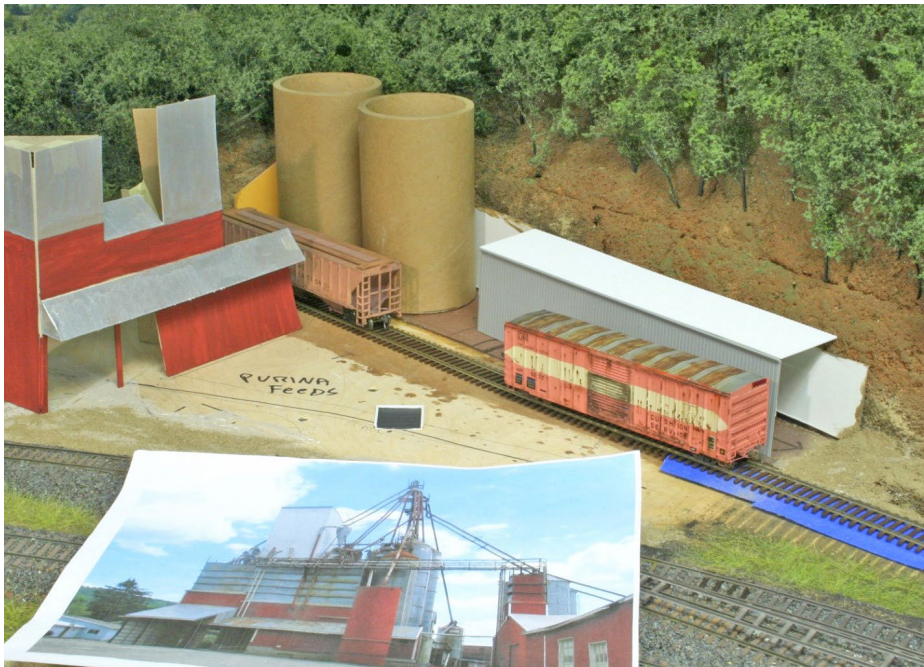

11. Next I tried the silo and building mockups in place, and began trying to figure out the best way to build the storage shed in this spot. My original intention was to use the retaining wall as the back wall of the structure, but I soon abandoned that due to the non-rectangular shape created by the retaining wall relative to the track. I'm using the prototype photo I shot in 2003, after the mill went out of business and apparently right before it was demolished, to see what prototype elements I could capture with this shed building. I decided to do the portion with the two white garage doors and omit the gable ended portion due to space constraints. But I realized I was getting ahead of myself, and went back to working on my bridge scene.

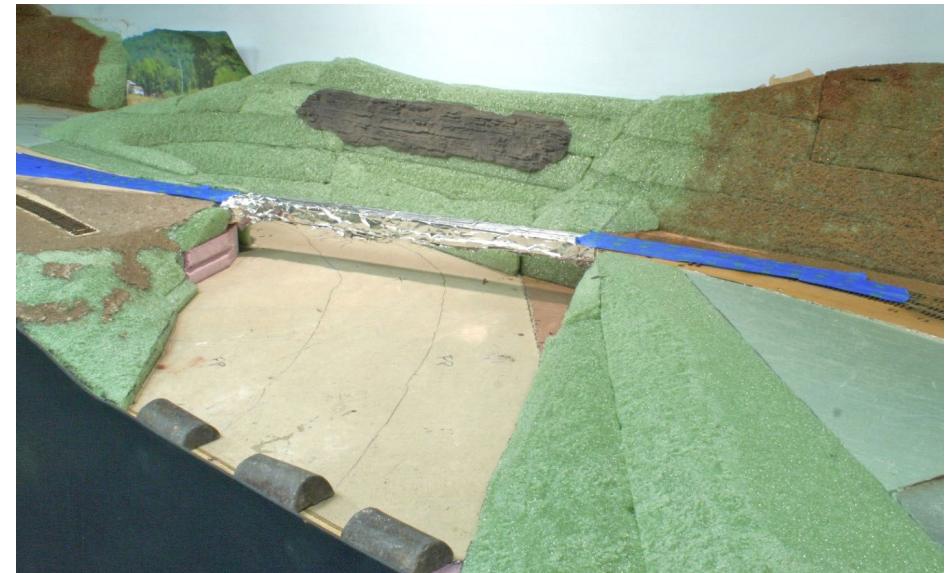

12. With foam all carved, it was time to get some paint and ground cover (read: dirt!) on it. The first step is always to protect the track with blue painter's tape, and I also used aluminum foil to protect the bridge girders that had already been glued on. The Cripplebush shale casting has also been hot-glued in place at this point.

107,000 have seen this MRH video - *have you?*

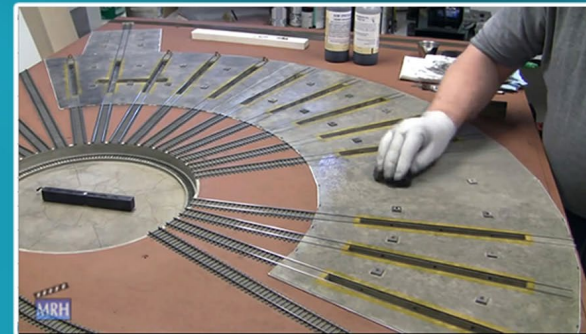

Watch the video now



## GETTING REAL | 16



13. Foil is useful for protecting the sky-painted wall too, along with more blue painter's tape. The methodology is pretty simple, in that earth-colored paint is liberally applied and brushed-in with lots of water sprayed on, followed by the immediate sprinkling of dried and sifted back yard dirt. The transformation is pretty dramatic, and proceeds very rapidly. In fact, it takes longer to protect the areas than to apply the scenic materials. Since I was interested in speed here, you can see that I used an old computer rack cooling fan on the left to rapidly dry the paint.

## GETTING REAL | 17



14. By using the fan, I was able to break for lunch, then come back downstairs and remove the foil and tape from the walls. This proved to be a fairly quick and high-impact transformation from bare plywood to something beginning to resemble a model railroad. For reference, to this point we're looking at just under two weeks of time passing.

Over 34,000 have seen this MRH video - *have you?*



**Watch the  
video now**





15. With the basic surrounding ground cover in place, it was time to get my bridge girders and abutments done so that the water could be poured. The abutments were cast by Russ Greene of New England Brownstone, and are his usual fantastic quality. He even cast in the metal protection on the point of the abutments, used as ice and debris shields. At his suggestion I used Pan Pastels, which I'd never tried before, for the basic abutment coloring, and enjoyed it. This is a weathering medium I'll definitely try on other things. The girders are being glued in place with black silicone sealer, an ideal way to fasten them, and the wing walls are assembled to each other with Canopy Glue. It's a busy but typical work scene on my layout.



16. Having the bridge girders all glued in place means that I can determine the proper height of the piers, allowing for the bridge shoes of course. Slices of regular green foam have been used to get the pier height just right, and glued in place with more Canopy Glue. The rocks and weights are also holding the abutment walls in place while the glue dries. I've also painted the Cripplebush casting with my custom-mixed paint that exactly matches the shale color in this area.

**Want to help keep  
MRH free?**

**Then *click* on ads!**



17. Once the abutment and pier glue has set, there's no obstacle to applying colored Sculptamold as a finishing substrate to the river bed. I mix standard ground cover latex paint, often purchased at the big box stores as "mistakes" at a greatly reduced price, right in with the Sculptamold and just a little water. The disposable gloves really save on an otherwise messy hand clean-up afterward too. I'm being careful not to get the mixture on the piers and walls wherever possible, but you definitely need them to look "planted."



18. I model the month of July, with rivers and streams at a fairly low point as compared to their peaks after storms and spring flooding. This scene is intended to have water in the center channel, and the flatter areas on either side are the flood plains of the river. I see this often in my travels in Pennsylvania and elsewhere. I elected to apply more dirt directly to the flood plains while the paint/Sculptamold mixture was wet. It was a good time to push some local rocks, picked up while visiting, into the Sculptamold. Additional weathering in the form of washes has been applied to the concrete piers and abutments.



19. I wanted to let everything set up properly over on the bridge scene side, so it was time to revisit the road scene side of the project. By this time I've had the backdrop photo printed at a photo lab, and have trimmed it to fit the area. And now begins the new (to me) process of getting a road to fit the photo backdrop. I'd seen this done successfully many times, but as you can see from the Sharpie lines all over the place that look like skid marks, that I was having a tough time getting the road to look "right." The gray shown is just paint, as I wanted to get the proper contour before commencing actual paving. But I couldn't figure out why I was having trouble picturing what to do with the road.



20. I decided that part of the problem was those aforementioned pesky "skid marks," and decided to paint the area to cover them up and apply a little more dirt. I deliberately shot this viewing angle to show how wrong the road looked from here, but I can assure you that if I stood more to the left, it looked just fine! I consulted with other friends who had done road-to-backdrop transitions (Mike Confalone and Tom Johnson) and both agreed that it was much easier to do it when the road entered the backdrop at a nearly 90-degree angle.



21. To show you I'm not kidding, here's the same exact scene, shot from a viewpoint to the left of the previous photo. You can see how the perspective totally changes! I ended up having my wife Karen, who has a real artist's eye, come down and help me out with understanding this. It didn't hurt to get her five-foot-tall perspective either! It soon became obvious that I would have to control the viewing angle of this to eliminate "wrong" views, and force the correct one, as you'll see coming up.



22. With the road location determined, I used wood strips as forms, and paved the road with a carefully mixed blend of lightweight spackle and powdered paint pigment. Here I'm stripping the forms.

**Did you see this MRH video?**



The ultimate "Yes, it's a model" video as James McNab switches NW 86th

**Watch the video now**





23. With the road in place, it was time to add the basic dirt ground cover, and ballast the yard and sidings. For the roads and dirt area that would become Pennsylvania Power & Light's siding, I used a mixture of grout and anchor bolt cement, sifted.



[Click here for reader comments](#)



24. Once again static grass makes the scene come to life.



**DID YOU  
KNOW MRH  
SUBSCRIBERS GET  
FREE BONUSES?**

**CLICK TO SUBSCRIBE NOW - IT'S FREE!**



25. For me, nothing makes a scene such as this come alive like finally pouring the water and getting some static grass in place! Since this was a flood plain scene, I put the grass in first, as I wanted a little water to migrate into it as I'd seen in various places while visiting my modeling area. While this scene is far from done, it looks so much closer to complete as compared to the last photo, that it spurred me onward! The water reflection from the bridge above was unplanned, and turned out to be a nice bonus that, in retrospect, should have been obvious. The area off to the left where the gondola is spotted is the Pennsylvania Power & Light siding, and those are transformers of various sizes that have been painted gray and glued to pallets.



26. Needless to say I could not resist running the first local into Towanda Yard to see how it looked on the bridge. The Masonite cars are of course destined for the big, and as yet un-built, Masonite plant which took 12 of these at a time inside the plant.

38,000 have read this MRH forum thread - have you?

[Home](#) / [Forums](#) / [Track and electrical/DCC](#) / [What DCC system do you use - and why?](#)

### What DCC system do you use - and why?

Mon, 2010-08-02 11:03 — joef [Track and electrical/DCC](#) [DCC - Electrical](#)

I'm curious what DCC system various modelers on here are using, and why? I think it's useful - so post a bit about the system you use and how you came to choose it. Also if you have any learnings, that's always helpful!

Read  
now





27. Here's a better view of the PP&L siding, with more brush applied to the river bank using Heki scenic materials. Now we're getting closer to the look I was after.



28. You could spend many happy hours detailing a scene like this! Here you can see a small tree has been added in front of one of the piers, as the local power runs light across the bridge as part of its switching moves.



[Click here for reader comments](#)



29. Here's the opposite side of the river bank, again using the Heki brush material. I think they're using poly fiber and applying static grass to it, based on the leftovers in the box. I apply it with hair spray, believe it or not.



[Click here for reader comments](#)



30. Here's what I mean about controlling perspective. In this view you can see the final transition of the road into the backdrop photo, nearly seamless and it looks correct. Because of the trees on the right, there's no view of it where it would look wrong, so the scene now works. The road is my usual lightweight Sculptamold colored with powdered paint pigments, with much care taken to get the color as close as possible. Using static grass and Heki brush to hide the transition from real to photo helps a great deal as well. Basic road weathering with Bragdon powders has been applied. And of course, having a fully ballasted and weedy yard in the foreground doesn't hurt a bit! I was pleased and a bit amazed at the depth achieved in this scene.



31. I deliberately took this shot from head-height, in order to show how the treed lump screens out the disappearance of the road. Somehow, and against my initial fears, the juxtaposition of the two scenes came out just as I'd hoped. This little Conrail local is pulling into Towanda Yard with cars for Osram Sylvania and the Masonite plant. That's a Bowser caboose on the rear that had its window openings modified by Brian Banna, from whom I got the unfinished model.



[Click here for reader comments](#)



32. This more finished view of the river scene features more small trees and underbrush, essentially leftovers from my tree making process. Most of the backdrop trees are in place, which helps to blend in the rock work too.



33. Another Conrail local is crossing the bridge with predecessor schemes clearly evident.

**When talking to hobby vendors, please remember to mention MRH.**

# GETTING REAL | 38

Please stay tuned for Part 2 where I will continue my project.



34. This compressed telephoto shot, taken with camera-on-rails, definitely captures the secondary trackage look I was after here.



Many species of Conifer trees available!



Also see our other conifer offerings ...





# 35th Annual National Narrow Gauge Convention Sept. 2nd-5th, 2015 in Houston, Texas

[Click here for  
more info ...](#)

Model Railroad Hobbyist | July 2015 | #65

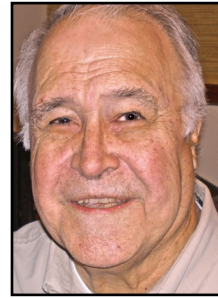

LARRY SMITH  
.....

## LITE AND NARROW

column



[Click here for  
reader comments](#)

### THE NEW MERKLE CONNECTING PART 3 | SOME OF THE STRUCTURES FOR THE TOWN OF NEW MERKLE ...

#### TCI&RR STYLE COMPANY HOUSES

**THE LOWLY COMPANY HOUSE. YOU WILL** find them all over the country. They still exist from the hills of Appalachia to the permanent logging camps of the Pacific Northwest. Everywhere you look you can find them, and depending on the location and the company, they are very similar in design.

The purpose of the company houses, as was the company town, was to provide decent living conditions at a mill, mine, or construction site for the workers. Oft-times these sites were far enough from the nearest town or city, and without adequate transportation, to allow the workers to live elsewhere and commute to work. While some of the towns were somewhat widely

► [RAMBLINGS ON THE NARROW GAUGE](#)



## LITE AND NARROW | 2

spaced and the railroad ran worker trains, similar to today's commuters, for the most part the homes were located very close to the work site.

Beginning in the 1880s, company towns became the usual pattern in the Birmingham District. The Birmingham District included not only the fledgling city of Birmingham, but the area from Tuscaloosa on the west to Anniston and Gadsden on the east. To the north it reached almost to Cullman, and on the south to Calera. Companies, large and small, developed these houses and minimal services for their employees next to their plants and mines.



1. Five of the square-top company houses are still in use today. They have been modernized with changes in the porches and siding. HABS/HAER photo John Stewart collection

## LITE AND NARROW | 3

Such was the case at New Merkle where 18 houses were built for the employees at the Cahaba pumping station. At the other end of the scale was the Sloss Company which, at the time of reorganization in November 1888, listed 1200 tenements and 31 stores, warehouses, and office buildings in their inventory. In the immediate Birmingham area, there were multiple designs for company houses. Shotgun houses and two-room houses were very common. The two-room frame design was of either side-by-side construction or like the shotgun style, front to rear.

The name “shotgun” came from the alignment of the front and rear door – a shotgun fired through the front door would pass without hitting anything out the back door. TCI (Tennessee Coal and Iron) had standard designs for this type of house and the one that we are building in this article.

In a discussion with Marjorie White of the Birmingham Historical Society, I learned that the pyramidal roof house did not come into use until 1904 or later. I also learned that this design was not built with board-and-batten siding, as they weren't built by a railroad and always used clapboard siding. The two-room houses were built with board-and-batten and did not have the pyramidal roof. Oft-times two-room houses were rented to two different men, making them a duplex.

For modeling purposes, the town of New Merkle consists of three company houses, a small lumber yard, and possibly a small company store or commissary, depending on the space available. The company houses are scratchbuilt using floor plans for the TCI&RR (Tennessee Coal, Iron and Railroad Company, which became part of US Steel).

The design is a four-room cottage that could be converted into a duplex and was commonly called a “square-top”. It had running

## LITE AND NARROW | 4

water on the back porch and a privy in the yard. Our particular house has a kitchen addition on the rear of the house, which was indicated in the floor plans we used. Many of these houses are still standing in the Bessemer, AL area today, so they are not limited to period layouts, but are useful for modern layouts as well.

My wife also indicated that a similar design was used for lake-side cabins in Wisconsin, so that might also be a use for it on your layout. I have taken modeler's license by building them in board-and-batten with a pyramidal roof. Alternative clapboard and windows are in the bill of materials section of this article.

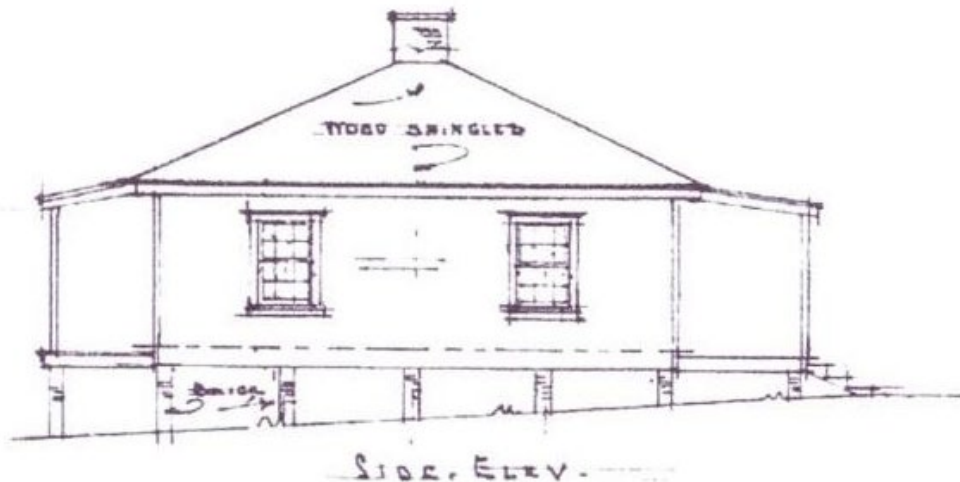

2. TCI four room cottage plan drawn by James Baird, retired TCI architect associated with the company's camps and villages from birth. His father, John Andrew Baird, joined TCI as engineer and construction superintendent in 1901. This drawing is from The Birmingham District used courtesy of the Birmingham Historical Society.

## LITE AND NARROW | 5

For more information on the Birmingham and surrounding areas, I suggest the following:

***Birmingham Bound, An Atlas of the South's Premier Industrial Region.*** National Park Service. A collection of maps, photographs and drawings by the Historic American Engineering Record.

**Special Publication from the Archive: *Two Industrial Towns: Pratt City and Thomas*,** a special publication from the archive of the Birmingham Historical Society. This is a free PDF download. [bhistorical.org](http://bhistorical.org).

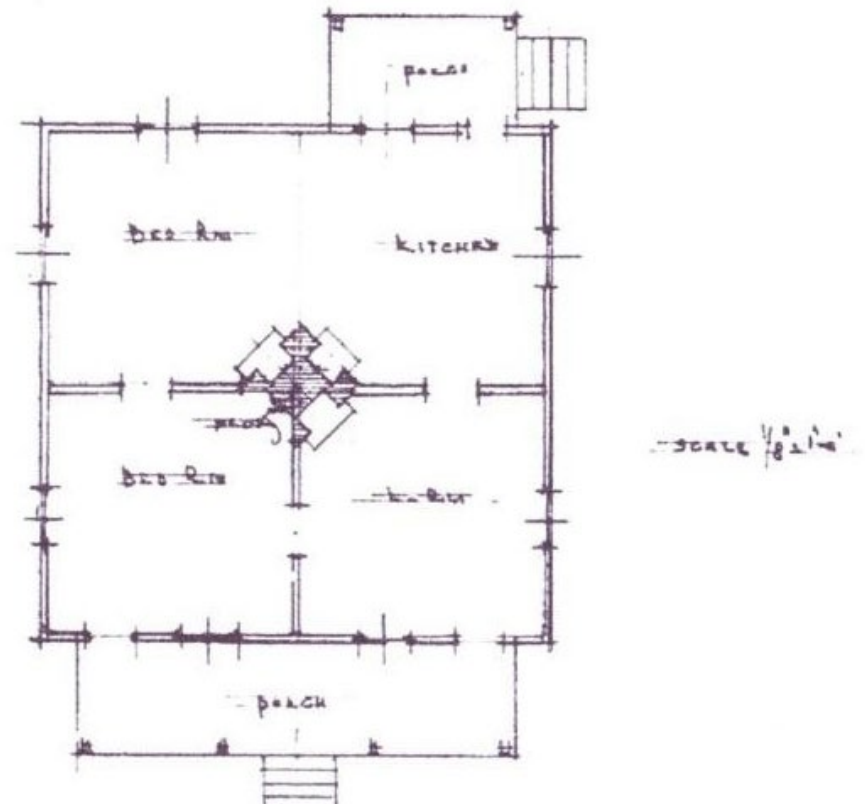

## Construction

In the last article I presented a mockup of the company house, just to get an idea of the size of the structure. I used this mockup to determine the quantity and size of the building materials needed to complete the structure. While these structures are constructed in O scale, I will give all dimensions in feet and inches so that you may build them in your scale.

I began construction by first staining the board-and-batten sheets using Silverwood by Builders in Scale. I do the whole sheet to prevent warpage that can occur with smaller pieces. If you are interested in building another version of this house, you may substitute clapboard siding as is listed in the bill of

.....

## BILL OF MATERIALS

### One company house in O scale

*(Multiply by the number of houses you intend to build)*

#### For board-and-batten house:

*Posts Corner and porch:* One package scale 8" x 8" lumber. Mt. Albert #MA332P24

*Walls:* Two sheets board-and-batten siding 4" x 24" Mt Albert #MA762B24

*Floor:* Two sheets 4" x 24" x 1/16" basswood

*Roof:* One sheet 1/32" x 12" x 24" Birch plywood

*House supports:* 1/4" x 1/4" x 24" basswood strips

*Windows:* Grandt Line # 3706, 9 required

*Doors:* Grandt Line #3619, 4 required

*Roofing:* Builders in Scale #733 ribbed-seam roofing.

*Steps:* Builders in Scale #7816 stringer, #7836 treads

#### Alternate construction:

*(See text for ideas)*

Substitute the following for a more prototypical structure:

*Walls:* Two sheets clapboard siding 4" x 24" Mt. Albert #MA742B24

*Windows:* Nine Grandt Line 3753 36" x 56" window double-hung – 6/6 light

#### Tools:

X-Acto knife with #11 blades

Modelers square

Hobby saw

Scale or architectural rule depending on scale

Heavy-duty scissors

Builders in Scale #7820 step tool

Micrometer

Emery boards and sanding sticks

I have a Miter Master that I use instead of a chopper, just for convenience.

#### Paint and glues:

Aleene's Tacky Glue for construction

Microscale Micro Liquitape for window glass and shades

Model Master Aged Concrete paint for the roof

Scalecoat Oxide Red for the structure

Testors flat white for windows, doors, porch posts and any trim

Builders in Scale Silverwood stain ■

## LITE AND NARROW | 8

materials. I also stain the scale 8" x 8" and 12" x 12" strips at this time. While I didn't do it, the scribed siding for the porch floors should be stained now as well.

From the board-and-batten sheets, cut two pieces 10' long. From the scale 8" square stock, cut two pieces also 10' long. Flip the board-and-batten pieces over so that the battens are face-down, and glue the 8" square stock to the end of each piece, acting as corner posts. Let them dry. Repeat this with two more board-and-batten pieces and the 8" square stock. While the pieces with the corner posts are drying, cut four more pieces of board-and-batten walls, and make two walls by gluing two of the pieces together. See [4] for this procedure.

Returning to the pieces with the corner posts, glue them together but only after removing enough material to make the

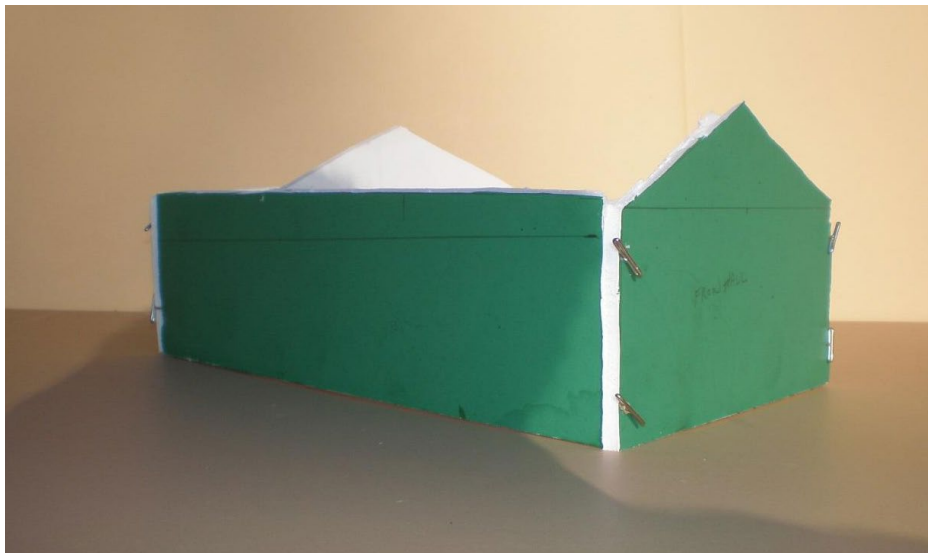

**3. The initial mockup of the company house. Two mistakes became quickly apparent: the house was too long, 48' instead of 44', and the roof profile was wrong.**

## LITE AND NARROW | 9

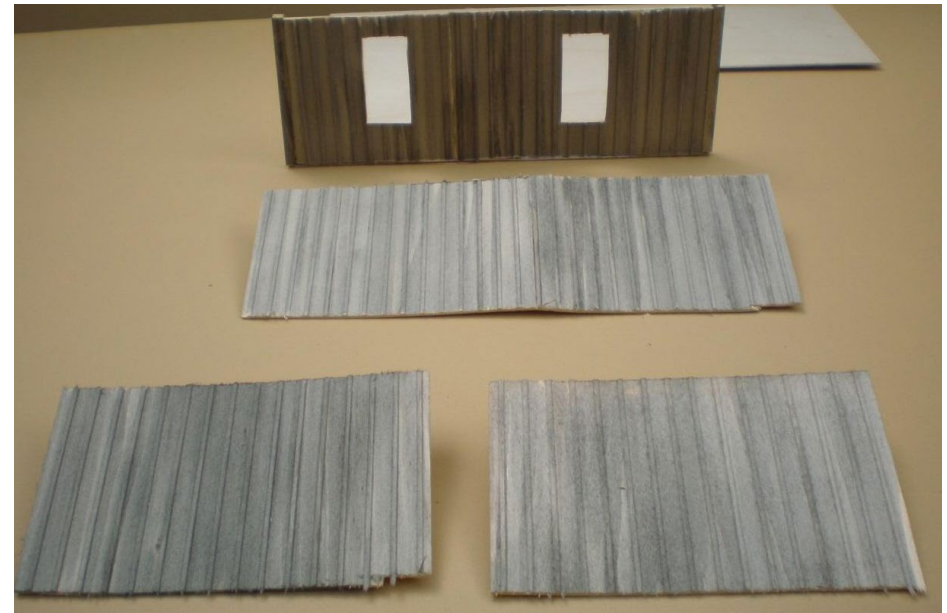

**4. Wall construction of the house progressing from individual sections of siding to the finished wall attached to the floor.**

walls 28' long, including the corner posts. Make the two walls without the corner posts 26'-8" long.

For the kitchen addition, you will need three more walls and two more corner posts. The two side walls are 14'-8" long, and are 10' at the junction with main house and slope to 9' at the outside edge. The corner posts are 9' tall, and the back wall is 12'-8" with a height of 9'

With all walls lying flat, choose one of the walls for the front of the house; preferably this will be one with the corner posts. Flipping the wall over to the plain wood side, measure in 11'-6" to the center of the door on each side. This front of the house

has two front doors, making it convertible to a duplex. Draw a line across the wall 12" from the bottom edge for the floor location and the bottom of the door. We are not going to put a framed floor in these structures, as they will never be seen when they are added to the layout. Both Tichy [tichytraingroup.com/Portals/0/Instructions/HOcatalog2013.pdf](http://tichytraingroup.com/Portals/0/Instructions/HOcatalog2013.pdf) and Grandt Line [grandtline.com/products/arch/architecture\\_model\\_parts\\_home.html](http://grandtline.com/products/arch/architecture_model_parts_home.html) give measurements of their doors and windows on line. You can use these to get the size of your openings. You can download this information and keep it on your workbench, or use a micrometer as I did.

I measured the door frame casting width, then divided it in half. Placing the micrometer on the center point, I identified the edges of the door opening, and ran lines from those marks to the line across the bottom. This was repeated for the second door opening. The next measurement was the height of the door opening. This was also done with the micrometer and marked. I drew a line across the wall showing where the tops of the windows and the second door would be. At the 5' center line for the windows, repeat the same measure and draw as you did for the doors.

Using a combination of the measurements from the floor plan that was published in the February issue, and the ones you just developed for the window height, mark the location for each of the windows and doors on each one of the remaining walls, including the addition.

Grandt Line windows and doors are molded in black styrene, making them difficult to paint with lighter colors. To overcome this problem, I spray-painted them with gray primer and allowed them to dry. I then sprayed them with Testors flat white

paint and let them dry. At this time, it is a good idea to insert the window glass.

**Building in Miniature:** *"Building and Weathering HO scale vehicles."* Bollinger Edgerly Scale Trains, [besttrains.com](http://besttrains.com).

Recently while watching a DVD on assembling HO trucks and cars, I saw an interesting method of putting in window glass. This was demonstrated by Chester Fesmire as he assembled a Jordan truck. One of the problems most of us have when putting in window glass is with glue smears.

What Chester suggested was the use of Microscale's Micro Liquitape. Take a toothpick or similar pointed object, and put the liquitape around the window inside the frame. Let it dry, and then insert your glass or clear styrene. If you get it wrong, you can reposition the window and there is no glue on the window. I also used the liquitape to add the shades at the end of the construction.

With the walls complete, we now begin to assemble the house. From the 1/32" plywood sheet, cut a floor for the house 28'x44', 14'x16', and 14'x28' using the floor plan from the last column. Attach the walls to the floor, and add bracing inside the building at the top and bottom, using scrap stripwood. You can brace

**When talking to hobby vendors, please remember to mention MRH.**

across the floor to make it stronger if you wish. Once the walls are in place, paint the entire structure your choice of color. In my case it was Scalecoat Oxide Red. I have seen photos of unpainted building as well as white buildings. If you decide to do the unpainted version of the building, do not paint your windows, only prime them and wash with India ink and alcohol.

There are two porch assemblies for this house. The front porch is 7' x 22' and is constructed using 8" x 8" framing. The framing was pre-painted using Testors flat white paint. Northeastern scribed siding was used for the flooring, and was pre-stained using Builders in Scale Silverwood stain. The porch posts are 8" x 8" x 8'4" and are pre-painted before installation. Space the posts on 5'-6" centers, and then attach a 22' 8" x 8" across the top to attach the roof. Attach the front rafter to the house using 8" x 8", attaching them to the top edge of the front wall. Cut the roof from 1/32" plywood and add the Builders in Scale ribbed-seam roofing. Paint the roofing with aged concrete from the Model Masters line of paints from Testors.

Construct the back porch similarly to the front porch. It measures 6' x 12', and has a framework constructed with 8" x 8" lumber. The porch posts and rafter are the same as the front porch. Do not make a separate roof for the back porch, as it is included in the roof for the addition to the house.

The roof for the addition and rear porch is a simple construction. Cut the roof panel from 1/32" plywood 22' x 17'. This will cover both the addition and the rear porch with a 12" overhang. Apply the ribbed-seam roofing. I painted with aged concrete.

The most complex part of this project is the main roof. It is a hip roof with a chimney at the very center of the main part of the house. Not having plans at the time, I guesstimated the

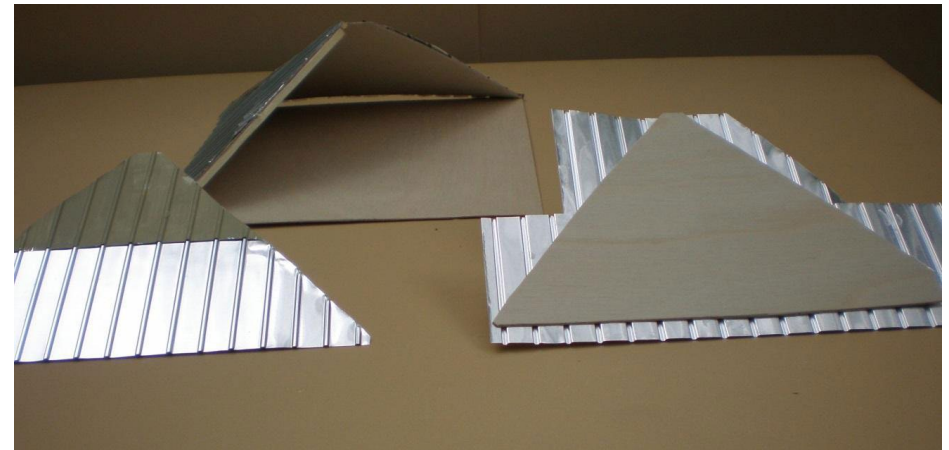

**5. Progressive assembly of the pyramidal roof for the house. The right section has the ribbed seam roofing glued in place waiting for trimming. The left roof piece has been trimmed and one section painted ready for installation. At the back is the roof with two sections already installed, but still requiring it to be tacked into place.**

height of the roof to be 8' at the center. In later plans, I found that I was off by less than 6".

Begin construction by cutting a 30' square from the 1/32" plywood. This is the base for the roof and will sit on the internal bracing of the walls. I spray-painted the underside of the roof flat white, and let it dry. Now comes the tricky part. To get the measurements for the four roof panels, I marked the center of the base and temporarily attached a 1/8" square piece of wood at the center point. I then laid a line, using a scale rule to the center post to the 8' mark, and measured the distance to the edge of the base. I transferred the distance to a sheet of 1/32" plywood. Make this the center of your roof panel.

Measure 16' on each side of the center line and draw a line from each of them to top of the center line, creating a triangle.

## LITE AND NARROW | 14

Remove the peak so that you will have a ½” opening at the top. Now that this is all done, here are the dimensions you need to make the roof: 30’ at the base, and 19’-3” to the top center of the triangle. Remove the point of the triangle to the 18’-3” level, making sure it is straight. Repeat three more times.

The first roof I built did not have internal supports, making it fragile. I highly recommend adding supports inside the roof to make it stronger. On subsequent houses, I added scrap strips of wood along the edges of the roof panels to strengthen them. It also makes for easier joining of the panels together. Another hint when doing your roof: glue the ribbed-seam roofing into place first, leaving a 12” overhang for the roofing. You can cut



6. The front of the house ready for weathering.

## LITE AND NARROW | 15



7. The side of the finished house. When installed on the layout a privy and clothesline will be added.

the roofing to the shape of each of the roof panels before, not after, installing to make a better seam at the edges. Paint the roof old concrete and install.

Finally, add a Grandt Line chimney to the center of the roof, and a smoke jack to the kitchen wall for the cook stove. Under the house addition and porches, place 12” x 12” x 2’ posts every 7’. Finish the structure with steps from Builders in Scale or your favorite supplier.

### Break time

We are going to take a break from the New Merkle Connecting to get some work done on the layout. We will be back in the near future with more on this project. I will show you how we

## LITE AND NARROW | 16

built the Boulder Valley and BTS cars for operation along with the Mt. Albert lumber yard.

Next time we are going for a change of pace with a railroad that isn't lite or narrow but is short. How about a USRA 2-10-2 on the roster?



[Click here for reader comments](#)

### Still available: a great new book about SP steam power!

#### Southern Pacific Ten-Coupled Locomotives

Robert J. Church

Bob Church, renowned authority on SP steam, presents a rich collection of information and photos about ten-coupled locomotives.  
How can I learn more about this book?  
How can I buy it?

[Click here for the answer ...](#)

*SIGNATURE PRESS*

MRHMAG.COM

Get the first 50 issues of  
**Model Railroad  
Hobbyist magazine™**

Save  
yourself  
endless  
hours of  
downloading

On a data DVD for \$10!

[Send me one!](#)

*(Sold by the MRH Store)*

*Includes a coupon  
good for \$20 off on  
TrainMasters TV*

*Over 5000  
pages of  
how-to  
information  
on model  
railroading*



- TABLE OF CONTENTS
- INDEX



# TRAINMASTERS.TV

## Railroad in a Depot?



# Coming in July!



Brought to you by

**MRH**  
MODEL RAILROAD HOBBYIST

Visit the TrainMasters TV website 



KEN PATTERSON

Model Railroad Hobbyist | July 2015 | #65

# WHAT'S NEAT WITH KEN PATTERSON

column



Click here for reader comments

## NEW CARS FROM JAHN3D ...

WE START THIS MONTH WITH MY FAVORITE photo so far this year, a sunrise shot. I open this month's video with the stunning shot on the next page that is set up outside. Shooting two-second exposures with an ASA of 100 and an aperture of f/22 created this beautiful sunrise photo showing off the detail of this Athearn tunnel motor [1].

See the next page ...

"Jahn Jens appears personally, with autos printed with a new material showing no layers."

▶ PHOTOS AND VIDEO OF SUPERB MODELS

## WHAT'S NEAT | 2



1. Athearn and the sunrise.

## WHAT'S NEAT | 3

Special guest Jahn Jens came all the way from Germany to be on the show. We featured his 3-D printed automobiles in HO scale in a video show last fall. He says his sales increased four-fold from that overview of his models by Mike Budde. This month he appears personally, with new models printed with a new material that shows no layers. 12 micron 3-D printing technology allows for detail like never before. How about the cross lines on the headlight glass? The layer-less detail looks fantastic. For the first time, he is also announcing auto interiors, auto glass for the models, and separate wheels, plus a new N scale line of autos. In the video, Mike Budde interviews Jahn and the two compare notes about modeling with this line of models from Germany. Available on line at [jahn3d.de](http://jahn3d.de). [2]



Playback problems? [Click here ...](#)



2. Jahn Jens (left) from Germany, and Mike Budde (right).

## WHAT'S NEAT | 4

Mike Budde painted and finished one of the new 12 micron printed cars three days after the interview.

This is the July show, so naturally I included a 4th of July ad photo shoot. This was done in total darkness, with the models set up outside at 4:30 in the morning. I used a flashlight to light the Bicentennial Boston and Maine locomotive. The camera was set to "B," for bulb, so the shutter could be open for a minute or longer to capture the shot. The aperture was set to f/22. To complete this beautiful night shot, Chris Palomarez at Athearn added the fireworks and moon from two other photos I had on hand [4].



3. Mike Budde's finished 12-micron printed car.

## WHAT'S NEAT | 5



4. 4th of July ad photo shoot.

### ADVERTISEMENT

## END OF TRAIN DEVICE

FLASH CIRCUIT  
UNDER TRUCK

TRACK  
POWERED



READY TO RUN!

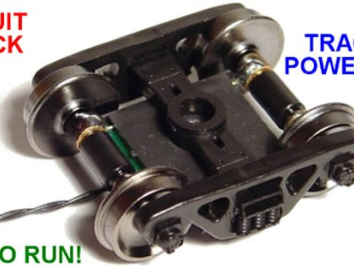

**Bright Red  
Flashing Light!**

Installs in minutes  
with no freight car  
modification required!

**RE RING**  
ENGINEERING

Patented Technology - US Patent 7,549,609

**Does not affect Load!**

↓ Car without Load ↓

↓ Car with Load ↓



For video  
and more  
click here!



5. 4th of July Athearn ad photo shoot.

## WHAT'S NEAT | 8

The next part of the video is an in-depth how-to on how I replicated this prototype BNSF yard scene in Minneapolis, MN for Athearn, for video and still photography. My job was to match the prototype photo as exactly as I could. I started with Micro Engineering turnouts and track, with weathered code 70 rail [5].



### 5. How to create a prototype BNSF yard scene.

This is Alec Holmes' prototype photo that I was asked to copy [5]. I spent a few days studying the photo and accumulating supplies for the job. I already had the background structures, like the 110-foot tall brass light tower and industrial buildings from Bachmann. They sort of matched the background buildings in the real photo [6].

## WHAT'S NEAT | 9



### 6. Alec Holmes' prototype photo.

## WHAT'S NEAT | 10

Here is a photo of the scene laid out on a piece of foam. I was able to find the actual location on Google Earth, see the bridge from which the photo was shot, and aerials of the yard scene. While this helped a little, it was what I saw through the viewfinder of my camera that dictated the layout of the scene [7].

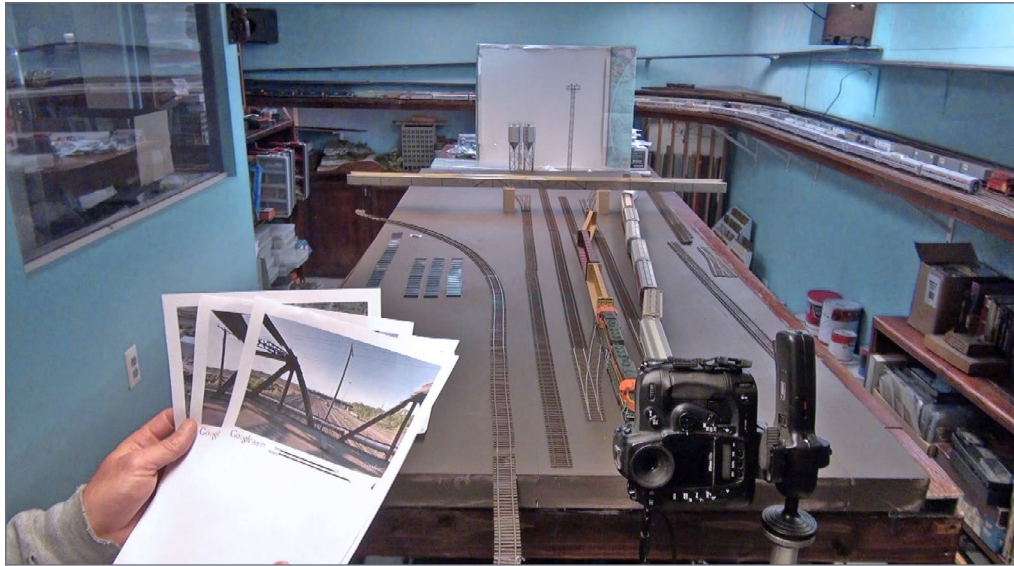

7. The building of the diorama.



[Click here for reader comments](#)

*Build this beautiful shelf layout step-by-step with Ken Patterson!*

**CHECK IT OUT!**



[kenpatterson.com](http://kenpatterson.com)

*click here to ...*

**Visit Ken's website**

**Ken Patterson builds a shelf layout using state-of-the-art methods**

## WHAT'S NEAT | 11

This is the scene I saw through the viewfinder of the camera while I was designing the photo. You can see the background props, the crossing railroad bridge, and the track positioned in the yard to match the prototype photo. I positioned a train with similar locomotives and freight cars, which aided in visually matching the length of the scene by simply studying the position and length of each freight car in the prototype photo [8].



8. Ken's camera-eye view.

## WHAT'S NEAT | 12

I soldered the track together with rosin-core solder. This kept things from moving around when I glued the track down with Liquid Nails, and allowed for electrical continuity so the scene could be run if worked in to a home layout. It also let me shoot video of moving models [9].

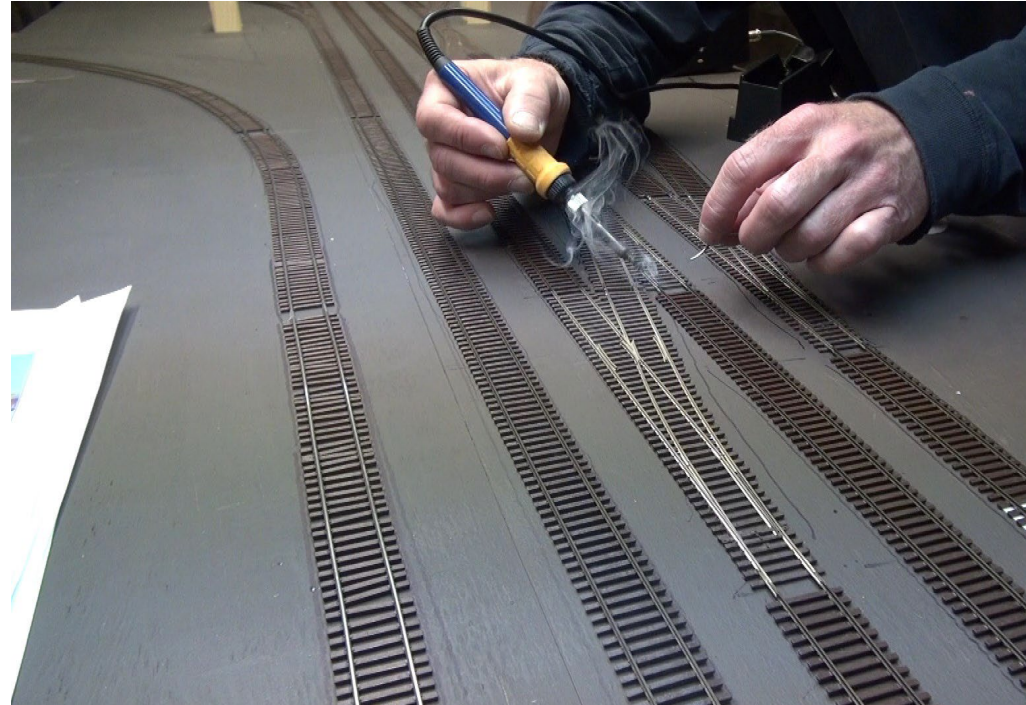

9. Building the trackwork for the scene.

## WHAT'S NEAT | 13

I painted the track and solder joints with Rustoleum Camouflage Brown paint. This added some weathering to the track work to make it look good after ballasting [10].



10. Painting the solder joints.

I roughed in the foam hill and bridge to get the right height in the scene, using a piece of wood and Micro Engineering 85-foot girders for the bridge sides [11].



11. Roughing in the foam hill and bridge.

## WHAT'S NEAT | 14

I carved the hill with a pruning saw. I like using this tool because the blade flexes and aids in the carving process [12].



12. Carving the hill with a pruning saw.

I glued fake fur to the shaped foam with Great Stuff Pro. This saved an hour and two steps. I did not have to seal the hill with latex paint and then glue the fur with Liquid Nails, which takes a long time to dry [13].



13. Gluing the fake fur to the foam.



## WHAT'S NEAT | 15

I painted the fake fur with hunter green and light green spray paint, and set it aside to dry for an hour [14].



14. Coloring the fake fur.

I glued the bridge girders to the wood deck with hot melt glue. This set up fast and was very strong. [14].



15. Gluing the bridge girders.

## WHAT'S NEAT | 16

The bridge pier in the scene had to be cut from a piece of wood using the band saw and then sanded round to match the prototype. I colored it with gray primer spray paint and weathered it with India ink. [16].



16. The bridge pier.

I put the bridge in place by gluing the pier with wood glue and gluing the deck to the hill with Great Stuff Pro. I had to add a ¼-inch slab of foam to match the track work's transition from the bridge to the hill. It came together really well [17].



17. Placing the bridge.

## WHAT'S NEAT | 17

I brushed dirt into the fake fur, allowing the tufts to show through. Sifted dirt was also applied around the edges of the yard scene. I then worked in some ground foam to add depth to the fake fur areas. [18].



18. Brushing dirt onto the fake fur.

Everything was glued in place with four bottles of Woodland Scenics Scenery Cement. I then weathered the track and ballast with an airbrush and some black paint, and a little camouflage paint from the can to kill the brightness of the ballast in real sunlight. This wrapped up what turned out to be 9 1/2 hour construction project to build the scene from start to finish. [19].

## WHAT'S NEAT | 18

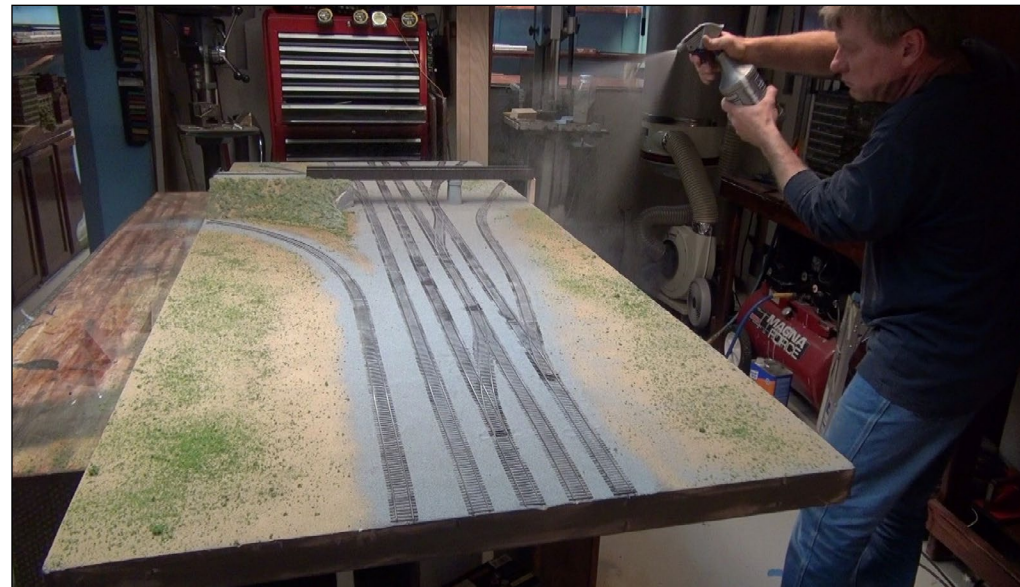

19. Spraying the scene down with Woodland Scenics Scenery Cement.

The following page shows the finished photo of the modeled scene. All the trains were matched to the scene and various yard details were added at the last minute while it was set up outside in the sun. I also added four feet to the back of the scene to hold the four tracks that curved away. The BLMA signal tower and all the background buildings and sagebrush trees were put into place. I cheated a little by using Photoshop to add the high tension tower and a building just over the top of the bridge. In the video you can watch the entire process in real time as I progress through the assignment step by step [20].



20. The finished photo of the modeled scene.

# FAST TRACKS

## YOUR VERY OWN TRACK FACTORY

Make the most of your modeling experience.

Build perfect trackwork easily and inexpensively when YOU want it!



Check out our extensive (and growing!) online video library to learn how easy it is to hand lay your own trackwork with Fast Tracks tools and supplies.

*Play Video* ►



shop online 24/7

handlaidtrack.com

1-888-252-3895

service@fast-tracks.net

## WHAT'S NEAT | 20

Next in the video we discuss building and weathering the BTS McCabe single-stall engine house. This is a laser kit that fell together in a weekend. I started the project by painting and staining all of the unassembled parts and building a Plexiglas base to hold the kit together. [21].

## WHAT'S NEAT | 21

After the walls were assembled, I applied a heavy layer of rubber cement to the whole structure. It dried in 10 minutes and was ready for paint. [22].



21. The BTS McCabe single-stall engine house in preparation.

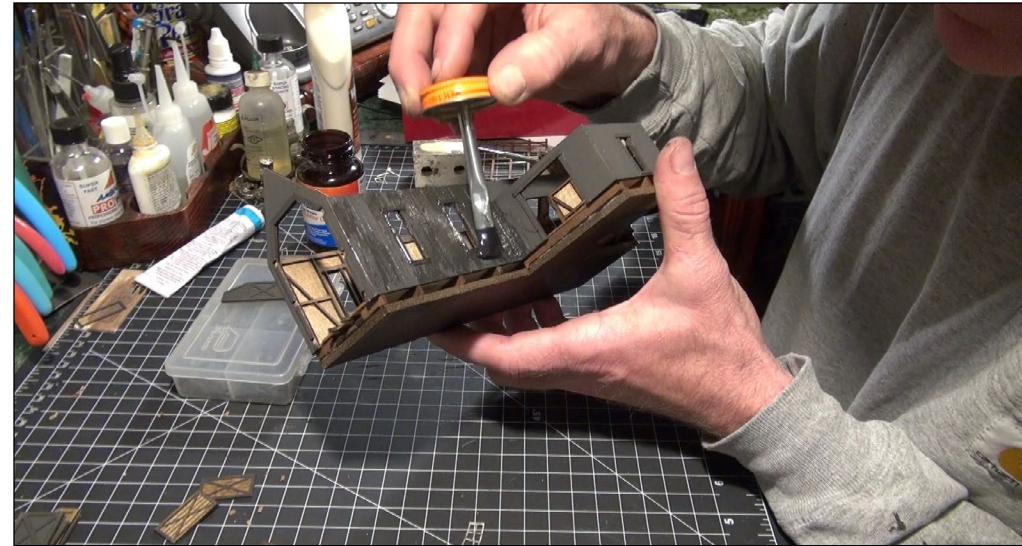

22. Applying rubber cement to the structure.

Want to help  
keep MRH free?  
Then click on  
Ads!

 Click here for  
reader comments

## WHAT'S NEAT | 22

I airbrushed the structure white with thinned Floquil paint sprayed at 20 psi. Doors and the eaves were also painted white after being coated with rubber cement [23].



23. Airbrushing the structure.

I used my finger to rub off some of the white paint exposing the darker weathered wood underneath. This simple process creates the effect of peeling paint.. [24].



24. Rubbing off some of the paint.

## WHAT'S NEAT | 23

As you can see in this shot, I left the roof open so I could see the detail and locomotives inside. I used a paint brush handle to scrape off the white paint from the eaves. [25].



25. Leaving the roof open.

The following page shows how the finished kit came out. It fit really well on the diorama. I cut out the back wall to allow the locomotive to run through the structure. It was a easy and fun kit to build. You can watch the process of weathering and installing windows in real time in this month's video [26].

To end the video, I answer a question that Richard Wane Schneider asked me on Facebook the other day: "Ken, how do you get all those big Locomotives into your yard to photograph?" Well, that's easy Richard. As you see in the two photos on the following pages, [27-28] we use cranes to lift the locomotives from the Union Pacific mainline in my back yard and up, into my yard for photography. The Big Boy was the most challenging lift to make.

Also: The St Louis RPM Meet will be August 7-8, so bring your best models to the show. You can come to my open house

## WHAT'S NEAT | 24

Saturday evening, which is coordinated with the show. We will have a bonfire on the bluff and run some trains inside and out, weather permitting. Happy birthday, America. You're 239 years old this month as we end the video with a few fireworks. There are seven great modeled runbys in several scales in this month's video that you can't see in the magazine text. Be sure to vote 5 stars in Readers Comments if you like What's Neat with Ken Patterson. Thank you for your support.



26. The finished engine house.



[Click here for reader comments](#)

## WHAT'S NEAT | 25



27. Lifting a Southern Pacific loco into Ken's yard.

# Bowser

## EXECUTIVE LINE

### HO VO-1000 Locomotives

Ready to Run, accurate painting and lettering, can motor with flywheels, RP25 flanges, deck mounted or body mounted side handrails, super detailed, numbered, Analog (DC) or with LokSound Select decoder (DCC and sound).

DC Version \$199.95 Sound Version \$299.95

Delivery Winter 2015

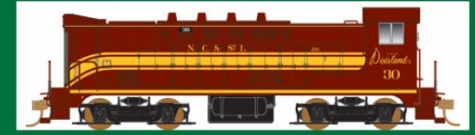
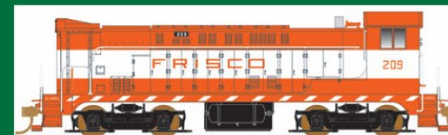
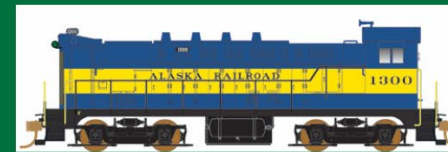

28. A better view of Ken's backyard destination.

Click here to check out the details for these and other great Bowser products!

# Heckman's Canadian Pacific

## A Photographic Journey

by Ralph Beaumont

Joseph Heckman was a pioneer photographer for the Canadian Pacific Railway. He photographed the line from coast to coast between 1898 and 1915, capturing the engineering works, stations, hotels, steamships, and the people who made the railway run. More than 4,000 of these historic images are preserved in the CPR's Corporate Archives, and 380 of them have been made available for this large format, hard cover book.

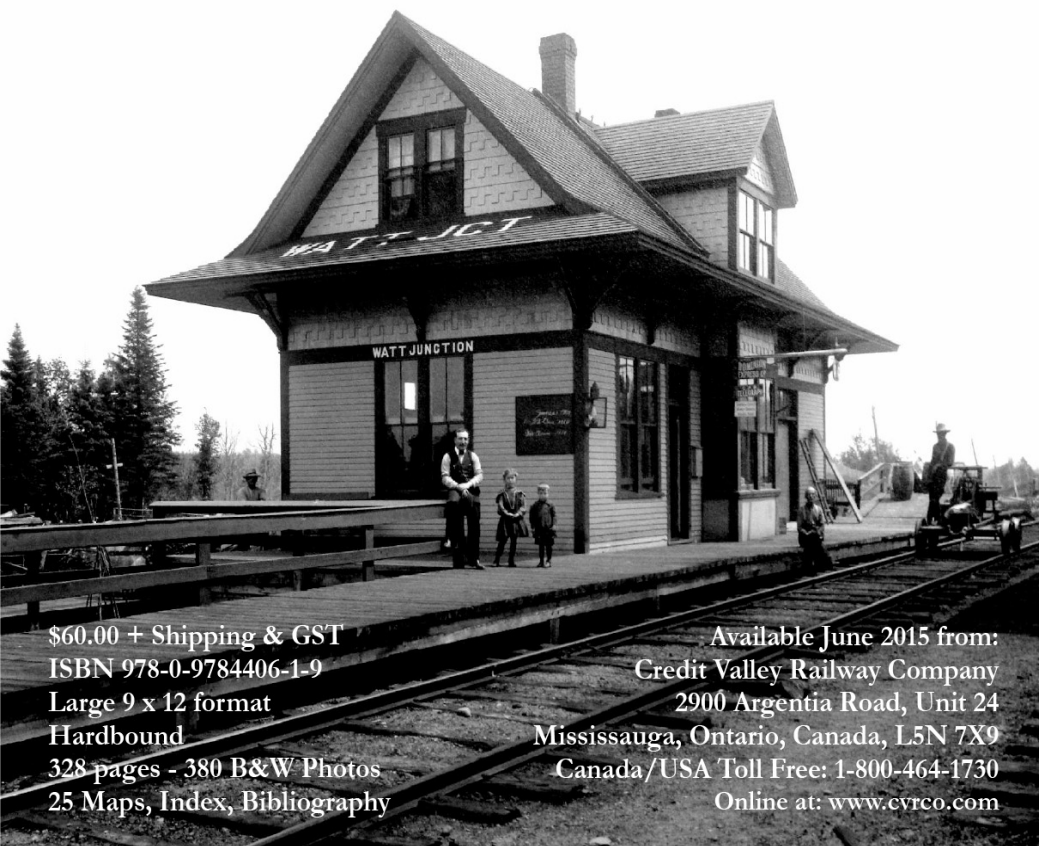
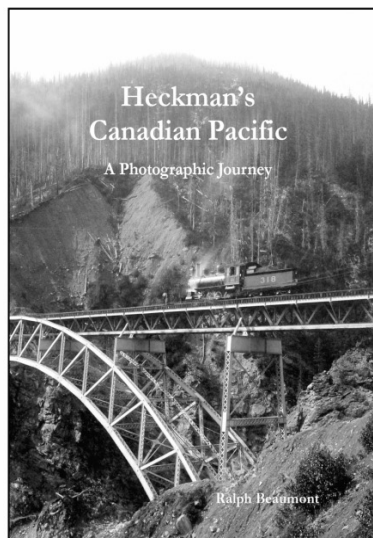

\$60.00 + Shipping & GST  
ISBN 978-0-9784406-1-9  
Large 9 x 12 format  
Hardbound  
328 pages - 380 B&W Photos  
25 Maps, Index, Bibliography

Available June 2015 from:  
Credit Valley Railway Company  
2900 Argentia Road, Unit 24  
Mississauga, Ontario, Canada, L5N 7X9  
Canada/USA Toll Free: 1-800-464-1730  
Online at: [www.cvrco.com](http://www.cvrco.com)

Model Railroad Hobbyist | July 2015 | #65

# IMAGINEERING

column

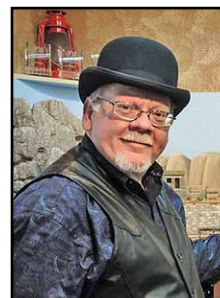

VERNE NINER



[Click here for  
reader comments](#)

## STARTING OVER: A TALE OF TWO LAYOUTS ...

**HAVE YOU EVER WISHED YOU COULD START OVER** with a model railroad project, saving the best of your previous efforts while building on your experience and following new interests? I found myself pondering this at the beginning of 2015. I was preparing to dismantle my current layout, change scales, and start all over again with something new. Ultimately, the best choice for me was actually to *rebuild* rather than start over from scratch. In the following pages I'll share how I am rebuilding my former On30 layout, the Estrella & Sonora Grande RR, into an entirely new concept and story. And along the way, I will show how changing circumstances and interests can (and should) influence your layout plans.

I have been "having fun with trains" for more than 45 years, and my interests have spanned different railroads over that time. Over the years, I have found historical research an absorbing hobby in itself, and I was intrigued by the rich mining and railroad history in

► [EXPLORING THE CREATIVE SIDES OF THE HOBBY](#)



## IMAGINEERING | 2

my home state of Arizona. The appeal of this history and the On30 locomotives introduced by Bachmann caused me to start a new railroad in 2007.

In choosing what to build, I wanted to follow a “path less traveled,” and freelance a unique railroad. I chose to model a 30” industrial copper mining railroad set in the early-1900s. I have lived in the scenic Sonoran Desert most of my life, and love its beauty and the blend of cultures that make it such a distinctive place. Legendary narrow gauge railroads (the 20” “baby gauge” Coronado Railway, Shannon Arizona Railway, Morenci Southern, and Arizona & New Mexico)

were too tempting to ignore. These served as inspiration as I planned my small copper mining empire.

### The Estrella & Sonora Grande RR

The E&SG was built in 1885 to tap the growing

1. A view from San Lorenzo yard on my former On30 layout, the Estrella & Sonora Grande RR.

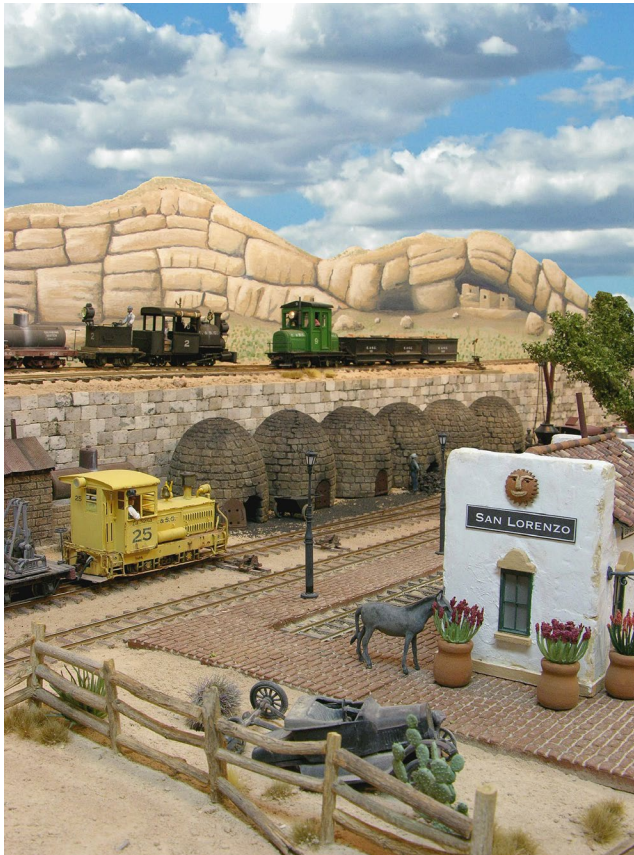

## IMAGINEERING | 3

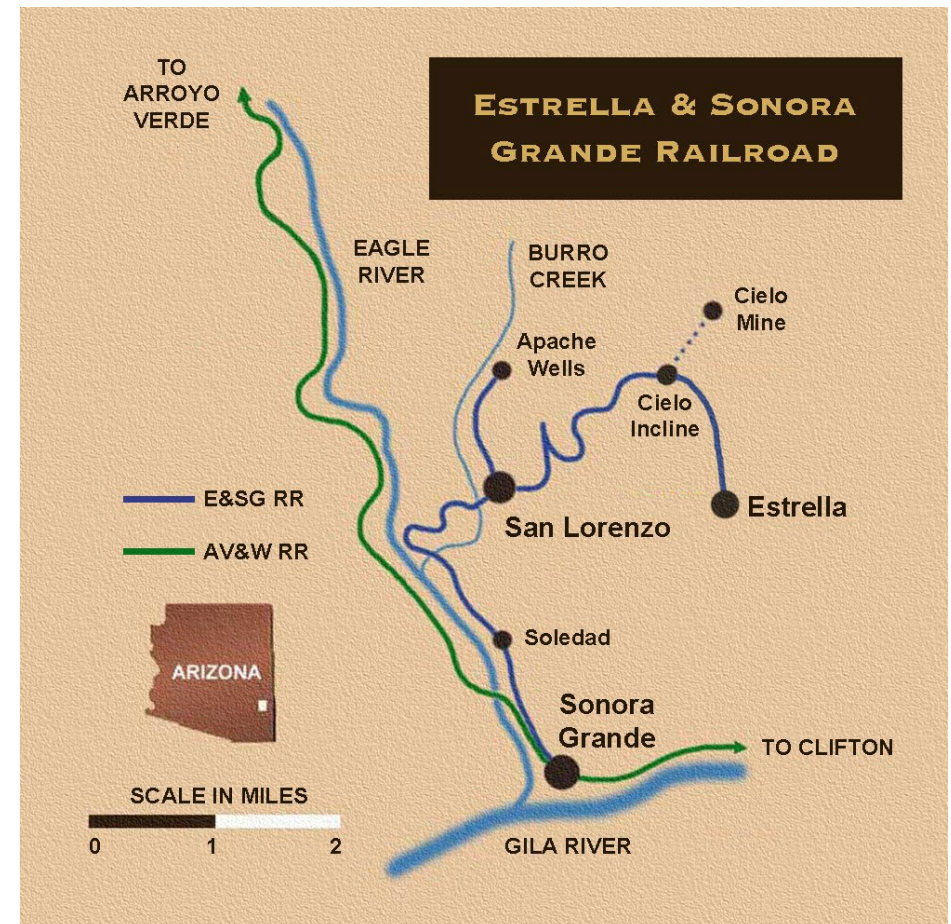

2. The route of the E&SG was based on a study of topographic maps of southeastern Arizona.

copper mining district on the western slope of Coronado Mountain in southeastern Arizona. This area was just across the mountain from Morenci, Metcalf, and Clifton, one of the largest copper mining districts in the world. The line began at the railhead with the Arizona & New Mexico RR in Clifton, following the San Francisco River south to the Gila River. It then proceeded west about five

## IMAGINEERING | 4

miles, and then turned north to follow the Eagle River all the way into Ponderosa Pine country.

E&SG trains would originate in Sonora Grande at the smelter, and run north to the mines at Cielo and Estrella. The Cielo Mine was accessed via a steep cable incline, patterned after the six prototype inclines in the Morenci-Metcalf area. One of these actually ran through a short tunnel, and the Cielo Incline does the same. The “face” in the rock to the right of the portal was called “La Boca del Diablo” meaning “The Mouth of the Devil.”

The incline and mine were dangerous places, as the wrecked mining cars demonstrate. This scene will remain on my new layout virtually unchanged.



3. A cable tramway pulls a pair of cars up through a short tunnel to the Cielo Mine.

## IMAGINEERING | 5



4. This old Porter locomotive was my first modeling project as I acquainted myself with On30.

Reusing the shelf benchwork and backdrop panels from a previous N scale layout, I set out to tell a new story. I took about a year to acquaint myself with On30, fiddling around with some temporary track on the benchwork and building some models while I considered different layout designs. Modeling in 1/4” scale is entirely different from N and HO. With just over 90 square feet available, I realized I had to be extremely selective in choosing what to model.

Planning for future expansion is always wise, and early-on I realized it would be impossible for me to choose between the smaller Porter tank locomotives and cars I wanted to model for the E&SG, and the larger geared and rod locomotives that didn’t fit with the smaller trains. In my thinking, 30” scale is a bit of a hybrid, particularly in

## IMAGINEERING | 6

the US. I find that On30 equipment usually looks best if it leans towards either 24" or 36" prototypes. Mixing smaller and larger equipment in the same consists never appealed to me.

I learned with my former layout that I could compensate for having less space by having a broader range of trains to run. So, I created a shortline railroad, the Arroyo Verde & Western, which connected with the E&SG at Sonora Grande. The AV&W was the parent railroad, roughly patterned after the 36" Arizona & New Mexico (parent of the Coronado Railroad). The E&SG was patterned more after the 20" "baby gauge" trains of the Coronado Railroad and Shannon Arizona Railroad. Depending on my mood



5. It would be impossible to model the Sonoran Desert without capturing its distinctive plant life. Here, "Lucky 7" climbs the switchback past saguaro and prickly pear cacti, yucca, agave and tumbleweeds.

## IMAGINEERING | 7



6. The drawbar on the pilot of #2 has a brass link-and-pin drawhead I designed with friend Bill Hay. link-and-pin drawheads were standard equipment on all E&SG locomotives.

on a given day, I could choose the type of equipment I wanted to run for a given operating session.

To improve the appearance of the E&SG trains, I equipped them with working link-and-pin couplers. The stock knuckle couplers seemed out of place on these little trains. My AV&W trains kept their knuckle couplers, perfect for when I wanted to do switching operations. Modeling both coupler types enabled me to visually distinguish one railroad's trains from the other's.

### The plan changes

It was clear a shelf layout would work best in my limited space... and of course I wanted at least one or two mining scenes, a small locomotive service facility, and a town. DCC was also on the list of must-haves. After considering dozens of designs, I opted for a simple around-the-room loop with a removable bridge to allow access into the room. All of the track is Micro Engineering Code 83, with the exception of the spur at Cielo Incline, which is Code 70. I operate the railroad with an NCE PowerPro 5 system, and most of my locomotives are equipped with Soundtraxx Tsunami sound decoders. I can switch to DC operation with the flip of a switch, and SPST switches are used to isolate tracks when in DC mode.

After I built the main line, I chose to add a branch line with a 4% grade up a switchback that climbed around the room. (I tend to change my mind a lot, but have learned it can lead to good results!) The branch line would allow one operator to run on the main line while another worked the branch line above. In my small space, two operators is the limit without bumping shoulders or trains all the time.

Adding the branch was an easy choice to make, but took effort to build. I made a real stone retaining wall of more than 1,200 individual blocks around 50% of the layout. The blocks were purchased in 16"



7. The E&SG as it was in 2014. (Artwork by Dave Meek, courtesy On30 Annual, White River Productions)

squares that are used for flooring. Each block was removed from its nylon backing, then soaked in boiling water in batches to soften the glue. The glue was removed from the back of each block by hand while the blocks were warm, then they were dried. Finally, each block was glued against the Styrofoam riser to make the wall. I used a light stain to enhance the texture of the stone and tone

down the gray a bit. The “Great Wall” became one of the distinctive features of the layout.

A transfer table was built to provide staging, with its four tracks aligning with the main line on each end. This allowed one of four trains to run continuously on the main line loop. The plan called for the mining town of Estrella to be built above to hide the transfer table. SPST switches were used to isolate each track from track power (DCC or DC) to safely disable trains not in use. Transfer table alignment proved to be a recurring problem, which led to the upper level never being built. The transfer table issue will be resolved for the AV&W by using an improved design to align the tracks with accuracy.



8. A construction photo showing the retaining wall made from more than 1,200 stone blocks.



9. This locomotive service area was removed in 2012 to make room for the village of San Lorenzo.

As the railroad was gradually completed, I ended up making a series of changes to represent the cultural influence from native Americans, Mexico and Spain. Making these changes first required making some tough choices. A favorite scene, including a small turntable and engine house, ended up being removed to make room for the village of San Lorenzo.

### Telling stories

I enjoy telling stories in my modeling, and San Lorenzo helped establish the E&SG's origins and “backstory.” From an operations sense, taking out an engine facility for a Mexican village seems counter-intuitive, but the design change really paid off in telling the story of the region.

## IMAGINEERING | 12

It was fun to build San Lorenzo, and unique sound tracks created by Fantasonics complete the effect. A Pricomm player and amplifier in the mercantile drive two high-bass speakers hidden on the module. This module won an award at the 33rd Narrow Gauge Convention in Pasadena, California in 2013.

The Mission San Lorenzo was based on the mission in Pitiquito, Sonora. It was built from blocks of florist foam, and covered with a stucco made from spackling compound and acrylic paint. Missions built in the style used across Sonora served as more than just churches...they were also community centers and in times of need, a refuge from marauders.

The scene around the fountain is probably the most unusual. you don't often see a model railroad with a pig in a fountain beside



10. The village of San Lorenzo included the imposing Mission San Lorenzo. This module is now part of Dave Meek's beautiful Thunder Mesa Mining Company layout.

## IMAGINEERING | 13



11. In one San Lorenzo scene, Ricardo pauses his carreta loaded with hay to have a chat with the priest in front of the mission.



12. The fountain in the square was made with acrylic clay, and the water was made from clear elastomeric caulk. The statue is a 1:32 pewter figure.

## IMAGINEERING | 14

protesting pistoleros! The pistoleros are angry that a pig is cooling off in the fountain that commemorates their fallen leader. Using the only means they can think of, their pistols they are urging the pig to leave.

Rosa, a lovely barmaid, is walking over to offer them a round of drinks back in the cantina. This will distract the pistoleros and buy the pig time to escape ... and if he doesn't, someone's having carnitas tonight!

A fun aspect of our hobby is the limitless opportunity it provides to create, including entirely new industries and products. In one of the tall tales from the E&SG, the natural gas "Frijolene" was discovered by accident. It was patented and originally sold as natural gas, but its

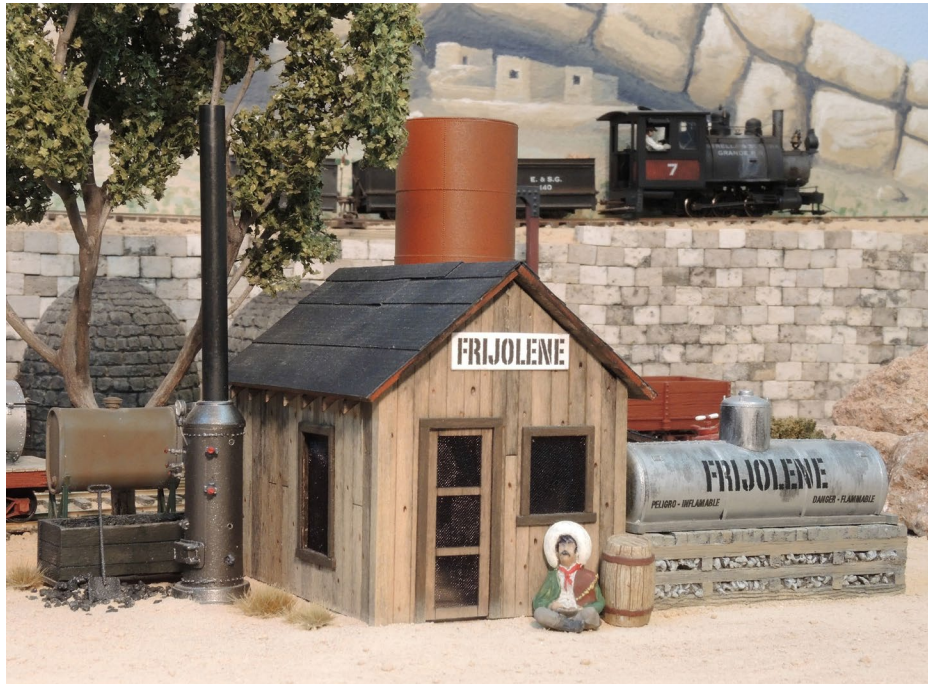

14. This was the second Frijolene plant on the E&SG. The first plant blew up, but fortunately nobody was hurt.

## IMAGINEERING | 15



13. The "Rockologist" Model T parked in San Lorenzo was based on prototype photos of an actual truck from Arizona's colorful history.

new formula is used as an additive to gasoline to give engines more pep "in the passing lane." Frijolene will be a major industry represented on my new layout.

### The Arroyo Verde & Western Railroad A New Beginning

After eight years of fun with the E&SG, I was ready to pursue something new. Recently, my hobby path took a U-turn when events caused me to rethink my future plans. Questions about how long we would be in our current home and other considerations gave me pause to think. Instead of building a completely new layout, it made sense to rebuild on the foundation of the E&SG.

So I decided I was ready for a new adventure in "recasting" my current layout into a completely new concept. I would keep a few

signature scenes and some favorite pieces of equipment, while following new interests. I could also fix some mistakes made along the way that have bugged me for years.

Here are the five simple steps I am following to design and build my new layout:

1. Define a new vision
2. Focus relentlessly on what to leave in, what to leave out
3. Change or fix what doesn't work for you
4. Create the plan
5. Build the layout

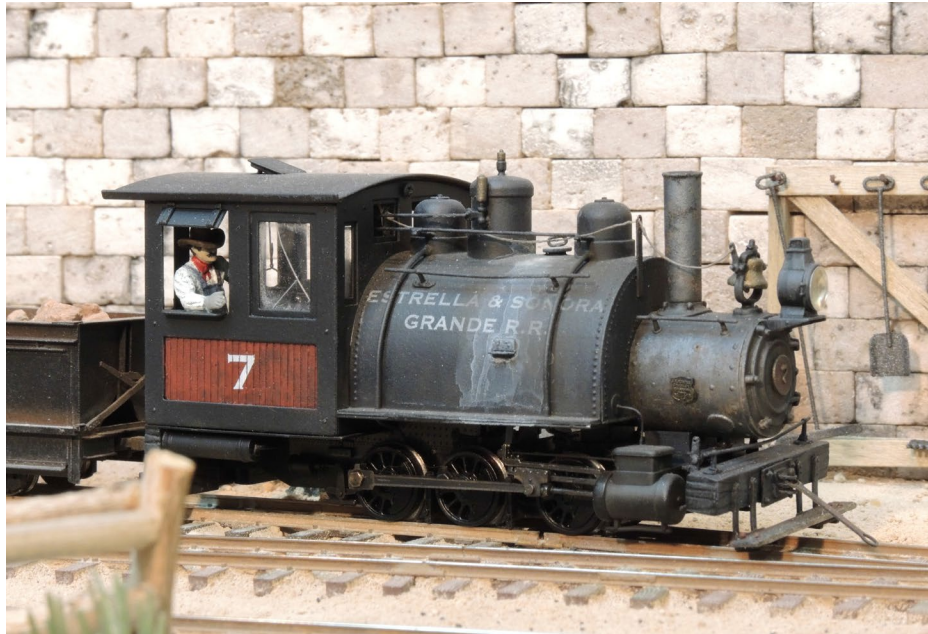

15. Lucky 7 which once narrowly escaped a boiler explosion, has moved north to work on the AV&W. Since the AV&W was the parent company of the E&SG, this was an easy rationalization to make.



16. AV&W #10, a Bachmann 4-4-0 with Tsunami sound, makes a quick water stop.

### 1. Define a new vision

My first thought was that the new railroad would need to represent a clear departure from the old. So, the name, look, and atmosphere would have to be substantially different. While some scenes from the old layout would remain, this new rationale would be planned around them so everything would fit into the overall theme.

My creation of the AV&W as a parent road for the E&SG offered an obvious choice: focus solely on the Arroyo Verde & Western for my next railroad project. Imagine a railroad built to reach a booming gold mining district, only to have the mines play out and coal replace gold as a profitable enterprise; connecting steamboat service on



Navajo River in its last years of operation; a new national park featuring ancient cliff dwellings in a scenic arroyo; and striking canyon scenery inspired by classic scenes from the southwestern U.S. My challenge will be to capture the essence of this railroad in about 90 square feet of layout space.

The history of the AV&W could fill a volume, so I will be brief. Gold found by prospectors near Arroyo Verde first brought quick claims, then serious investment and significant mines in the late 1800s. The AV&W was built to connect this rich mining district with the outside world. It also connected with steamboat service to mining camps down the steep Navajo River canyon, which were otherwise virtually inaccessible.

By the era I am modeling, mid 1920s-1930s, all but the richest mines had played out and steamboat service was nearing its end. Coal mining, tourism and Frijolene production had replaced gold mining as the principal source of revenue for the railroad. The growth in tourism was a response to the striking natural beauty of the area, and by several prominent cliff dwellings in Arroyo Verde that led to formation of a national park.

## 2. Focus relentlessly on what to leave in, what to leave out

Design considerations for rebuilding a layout differ from when “starting from scratch.” I boiled down the decision making to three points:

1. Relentlessly choose what you can fit into the layout – set priorities and keep them
2. Leave in what you don’t want to give up
3. Leave out what either won’t fit, or what doesn’t make the priority list

So, I created two lists: “Things I Must Have” and “Things I Want” (these are what the great layout planner, John Armstrong, called “Givens & Druthers”).



17. This scratchbuilt stucco station at San Lorenzo will be replaced by a more ornate station serving passengers transferring from trains to steamboats at Navajo Landing.

“Things I Must Have” include (listed by priority):

- Representations of the native cultural heritage of the southwestern U.S. (a model of a cliff dwelling or ruins).
- At least one gold mining operation.
- An ornate stucco-and-adobe passenger station with complete interior, including illuminated brass chandeliers.
- Operations to represent Frijolene production.
- Keep the extensive retaining wall and switchback to the Cielo Incline (I remember laying the 1,200 stones in the wall by hand and don’t want to do that again!).

## IMAGINEERING | 20

- Hidden staging that would be accessible and reliable.
- A reverse loop or turntable at the end of the switchback, and a turntable to turn locomotives at the other end of the layout for out-and-back operations.

“Things I Want” (listed by priority):

- A scene depicting small river steamboats that operated in the western U.S.
- A mining town sprawling over a steep hillside.
- A small engine house and service facility.
- A visitor center for Arroyo Verde National Park.
- A trading post and gas station (selling Frijolene, of course!).
- One or more tunnels.
- A small stock pen (The A-OK Corral or something similar).

### 3. Change or fix what doesn't work for you

Rebuilding your layout allows you to address your changing priorities, and to fix mistakes or problems that can drain the joy and fun from the hobby. My E&SG had a number of these issues that strained my interest and enthusiasm. My list of fixes includes:

- Restore continuous running – I want to again enjoy the simple pleasure of watching a train roll through the scenery.
- Place more emphasis on switching operations – I enjoyed exploring the use and operation of link-and-pin couplers on my E&SG, but they are not easy to use when trying to switch cars. So I will be using only knuckle couplers on my new layout.
- “Nuke the clutter” and restore the railroad room to a pleasant environment

## IMAGINEERING | 21



18. E&SG #4, the Sidewinder, awaits orders to take a final work train up the grade to pull up rails. She will serve on the AV&W once she receives knuckle couplers.

### 4. Create the plan

There's a huge body of work available on the subject of planning layouts – track planning, layout design, etc., can be a rewarding facet of the hobby. Currently, my plans for the AV&W are only in my head. I plan to share the new layout's design and track plan in a future column.

### 5. Build the layout

Construction of the layout will also be the subject of future columns. The work required to transform the layout into the AV&W will be fun and will involve:

- Completing benchwork over the transfer table (hide the hidden staging).
- Revising the backdrop.
- Revising and enhancing the scenery.
- Updating my equipment roster.
- Updating my plan for operations.

I am eager to begin work on the AV&W. Follow this column for future installments where I describe my progress in detail. Until then, happy trails and clear rails to you! ☑



19. Here an E&SG work train passes the coke plant at San Lorenzo (the coke plant was originally located at Apache Wells). The coke service track will soon become a switching lead to a Frijolene plant just beyond the layout borders. The backdrop will be redone to reflect different scenery on the AV&W.

Want to help  
keep MRH free?  
Then click on  
Ads!



[Click here for  
reader comments](#)



# HOBBY MARKETPLACE

**LOOK**  
at what's new at  
Black Cat this month

**Click here for  
our orderform**

**Private owner cars  
We have decal sets for:  
15 different tank car sets  
18 trailers & piggybacks**

**Black Cat Publishing  
234 Lindenwood Dr. W.  
Winnipeg, MB R3P 1X7  
(204)489-5005  
ajfergus@mymts.net**



**Don't settle for lifeless signals!  
We've got signaling circuits!**



**LOGIC RAIL™** "Sophisticated  
TECHNOLOGIES Model Railroad  
Electronics"

Please visit our website and online store!

21175 Tomball Pkwy Phone: (281)251-5813  
Suite 287 <http://www.logicrailtech.com>  
Houston, TX 77070 [info@logicrailtech.com](mailto:info@logicrailtech.com)

**Jelsma Graphics** AMERICA'S NUMBER ONE  
RAILROAD PRINT SOURCE

Railroad Art-Prints,  
Caps, Jackets,  
Shirts and More ...  
Jackets starting  
at \$79.95

[www.jelsma.com](http://www.jelsma.com)  
1-904-221-3513 • Jacksonville, FL.

**BenchWork.com**  
Affordable track planning  
starting at \$250



**RULERS-of-the-WORLD**  
Scale Rulers \$4 each  
Over 200+ scales!  
Metric or Imperial  
[www.rulers-of-the-world.com](http://www.rulers-of-the-world.com)

Can't remember which cars you've bought?  
**Yard Boss**  
**Model Train Inventory Software**  
from DCC by Design  
Under \$15  
Download free trial now  
[www.dccbydesign.com](http://www.dccbydesign.com)

HO Scale Passenger Car  
Lighting Board Kits

- More LEDs (16)
- Best Anti Flicker
- 1 Farad Super Caps. Inc.
- Adjustable Brightness



- \$19.95 + Shipping
- N Scale also available.

[www.voltscooter.us](http://www.voltscooter.us)

**clever models LLC**  
Cardstock models & materials



kit bash by Robert Bruce

[www.clevermodels.net](http://www.clevermodels.net)

**GRAND CENTRAL MODEL RAILWAY**

Ph: 0448534212  
What we do:

Benchmark, Layout Design, Display Cabinets, Layout Photography,  
Backdrops, Home Consultations and Valuations  
[www.australianpacificrailways.com](http://www.australianpacificrailways.com)



**Yarmouth Model Works**  
HO scale resin kits and detail parts

U.S.A. MAILING ADDRESS  
3560 Pine Grove Ave. Unit 617  
Port Huron, MI 48060

TEL: 519-633-7574  
[pierre.oliver@start.ca](mailto:pierre.oliver@start.ca)  
[www.yarmouthmodelworks.com](http://www.yarmouthmodelworks.com)

CANADIAN MAILING ADDRESS  
85 Hiawatha St.  
St. Thomas, ON N5P 2T5



**LIGHTS4 MODELS**

LED Approach Lights

- 20 Cool White LED Pairs
- Circuit Board Control
- 10 Lights Sequence!

LED LIGHTS | NEON SIGNS  
NEW PRODUCTS  
ADDED MONTHLY

Click Here

Input Voltage: 12-19 Volts  
Universal AC/DC



**PRE-SIZE MODEL SPECIALTIES**

P.O. Box 6 Paonia, CO 81428  
Ph. 970 527 4586  
Made in The USA

Cast resin items for All Scales.  
Tunnel portals, bridge piers, abutments,  
culverts, and retaining walls.  
Trackside details and sage brush tree  
armatures.

**True Scene™ Modeling**

**NEW FusionFiber™**

Scenery Base Material for the 21st Century!  
**SATISFACTION GUARANTEED!**  
[www.truescene.com](http://www.truescene.com) or 716-523-7305

**Hobby Marketplace Ads are Economical and Effective.**

PRECISION DESIGN CO

Chains  
Flat Car loads  
Joint Bars  
Signs & Posts



**FREE SHIPPING**

**MOUNTAIN SUBDIVISION HOBBIES**

[www.modelrrsupply.com](http://www.modelrrsupply.com)

FREE USA SHIPPING OVER \$29.00

NCE - SOUNDTRAXX - DIGITRAX - PECO - CIRCUITRON  
DCC SPECIALTIES - INTERMOUNTAIN - CMX - ATLAS  
BAR MILLS - BOWSER - KATO - MRC - TOMAR - RIX -  
PIKESTUFF - LOGICRAIL - CENTRAL VALLEY AND MORE!

MODEL RAILROAD

**BenchWork**



Affordable built to order Benchwork starting at only \$20 a Sq Ft.

CLICK HERE

**CANYON CREEK SCENICS**



**Great Decals!**<sup>TM</sup>

FEC, Interstate, Virginian Railway, & L&N Titles  
After Hours Graphics Line  
Coupler Gages and More  
In O, S, HO, and N Scales



GOLDEN AGE LINE

**WESTERFIELD**

MODELS, LLC

**NEW N.A.R. STK CAR KIT!**



RESIN KITS, DECALS,  
DATA DISKS & DETAIL  
PARTS AVAILABLE.

[westerfieldmodels.com](http://westerfieldmodels.com)

**Don't miss The Eagle!**



- Enjoy 4 full color magazines per year
- Plus a 12-month full-color calendar
- 2015's annual meeting in Houston, TX
- On-line company store featuring special run MP models, books and much more.

**To join:** go to [mopac.org](http://mopac.org) or e-mail [marketing@mopac.org](mailto:marketing@mopac.org) for more info.  
Or send \$35 for your membership to:  
**Missouri Pacific Historical Society**  
Membership Services  
P.O. Box 138  
Bucklin, MO 64631-0138

V2

When talking to hobby vendors, please remember to mention MRH.

Have you seen these popular blogs on the MRH website?



**Tom Johnson's L&N**

247,000 reads

CLICK TO READ IT NOW



**Ken Glover's Shelf Layout**

72,000 reads

CLICK TO READ IT NOW



**Trees**

Evergreen  
Conifers for HO, N, S, and O Scales

Make Your Own, Save Money and Have Fun

Real Wood Trunks

All Components Available Separately

Made in Oregon, USA



[coastmans.com](http://coastmans.com)

Your ad could be in this space for just \$57 a month.

Click to learn more ...

# SIMPLE SCRATCHBUILT



## **METAL BLOCK LOADS**

BY M.R. SNELL  
.....

### ***Build a great looking load for your flatcar*** ∞

**ONE GOAL OF EVERY MODEL RAILROADER IS** to have an interesting layout, and fewer things draw more attention than an open-style freight car carrying a load. Although visually appealing, these can often seem daunting to model, especially for those who have never attempted one. Recently I observed

several loads featuring large metal blocks carried on top bulkhead flatcars. I realized these are easily modeled using styrene shapes and sheet. Best of all, they do not require perfection. These are presumably aluminum, and each block is essentially a “raw material” that is rough and imperfectly formed. This makes an ideal project for those new to scratchbuilding, because it enables modelers to develop their skills without the accuracy required in projects like structure construction.

 [Click here for reader comments](#)

Let's start with a closer look at the load. The load is carried on a standard bulkhead flatcar, and consists of six large rectangular blocks, stacked in three groups of two, using wood runners to separate them. Each group is then placed onto larger runners mounted on the flatcar deck. Those are then strapped together and secured to the flatcar deck using bright yellow web strapping. The strapping is a feature that really stands out against the weathered car carrying the load.

A good look at the blocks themselves shows that their weights and sizes are stenciled onto their sides. This eliminates the



**2. These large metal billets make an interesting load that can be easily replicated in model form, complete with tie-down straps.**

## SIMPLE METAL BLOCK LOADS | 4



**3. Close examination of these large metal blocks reveals the size and weight is stenciled on the side of each block.**

complicated calculations often required when constructing an open load. After studying several prototype loads, it appears that these blocks are generally around 26 inches high, 72-74 inches wide and around 164 inches long.

I chose a specific load to model, and the materials used to duplicate it. For this project I will focus on the smaller-style blocks mounted on top a standard bulkhead flatcar. Since great detail is not required, there is a variety of media to work with. I could use styrene, metal, and wood. Of the three, styrene will most likely give the best result. It has no grain and can be cut, sanded, and glued easily.

Next I chose a method for constructing the large blocks. I could use solid strip, simply cutting it to size. Unfortunately it can be nearly impossible to find solid strip stock of those dimensions.

## SIMPLE METAL BLOCK LOADS | 5

A second method is to laminate styrene sheets or strips together until they are one solid piece that can be cut to the correct dimensions. This method is effective, but the downfall is that the layers have to be blended together by puttying and sanding. A third method (the one I chose) is to find a suitable styrene shape that could be used as a starting point.

Styrene shapes are available from a variety of sources. Though I was not able to precisely match the dimensions stenciled onto the prototype, I decided that a Plastruct RT-28 rectangular tube would fill the bill. Molded in gray ABS, the hollow tube keeps the weight of the load down. The 3/8" x 7/8" dimensions are slightly oversize for HO scale, but would not be glaringly obvious. As a bonus, the 15" long strip would yield seven blocks per strip, allowing me to make a full load with a single strip.



4. The large metal blocks can be easily duplicated using styrene shapes and sheet.

## SIMPLE METAL BLOCK LOADS | 6

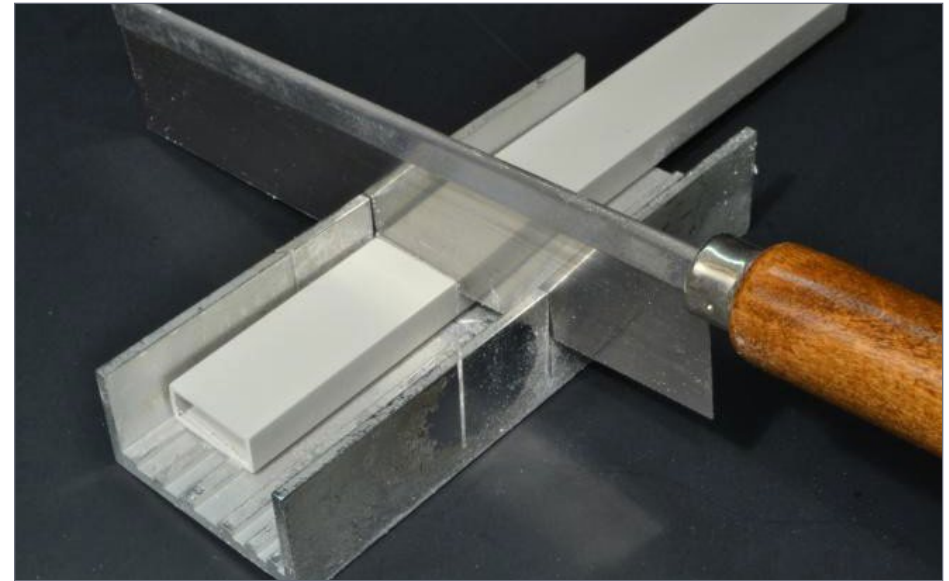

5. When working with styrene shapes, the best method for a clean cut is to use a hobby saw and mitre box.

I converted the long tube into individual 164-scale-inch sections that would form each block. Absolute accuracy is not a requirement here, but reasonably accurate cuts are still wise when sectioning the styrene tube. One method for achieving clean-accurate cuts is to mark the cut line in pencil, place the strip into a mitre box, and cut through it with a fine-tooth hobby saw. This will ensure that the cuts are even across both the width and height of the material, leaving the rough edges to be cleaned up later.

Once each "block" has been cut, I noticed the styrene along each cut edge is rather fuzzy. It might even have small remnants of styrene along the inner and outer edges. It is necessary to smooth these rough spots to make sure the styrene sheet will sit flush and have a good surface for the glue. I removed any styrene



## SIMPLE METAL BLOCK LOADS | 7

remnants by running an X-Acto blade along the inner and outer edge of the cuts. Then I lightly filed across them with a wide nail file found in most chain drugstores. These inexpensive pink files have enough grit to smooth the surface without making deep scratches. They are also wide enough that the entire end can be done in a few passes.

Now I added the ends to the blocks using styrene sheet. Styrene modeling sheet is available in various thicknesses starting at .005" and working upward to over .100" thick. For this project I used thin .005", so its thickness doesn't show on the sides of the block.

I began by cutting 12 rectangular sections of sheet, each 1.0 x 1.5 inches. These became the ends of each of the six blocks. Next I stood a block upright on each rectangle, and lightly traced

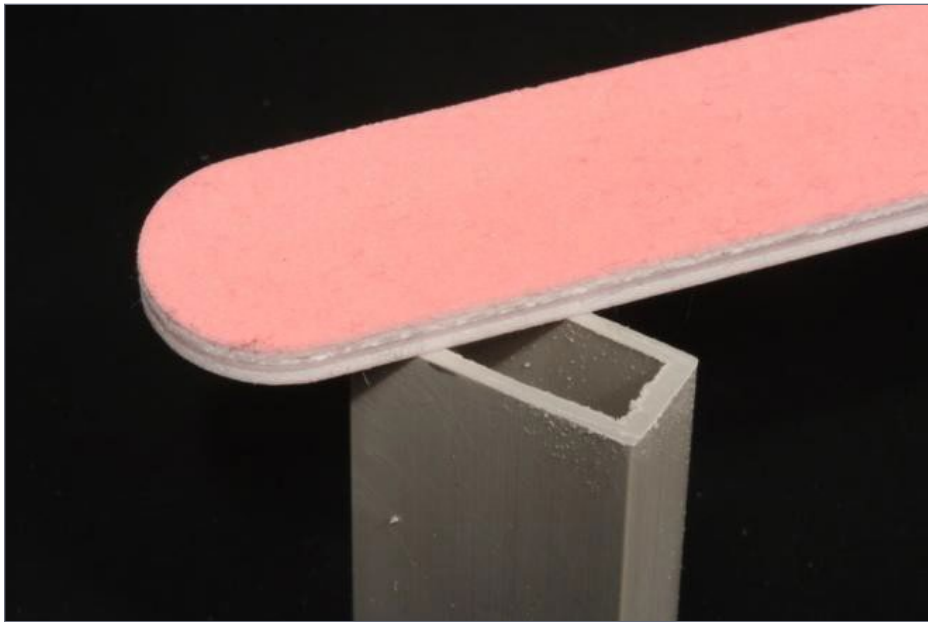

6. An inexpensive salon file is excellent for removing the fuzzy edge often left when cutting thick styrene.

## SIMPLE METAL BLOCK LOADS | 8

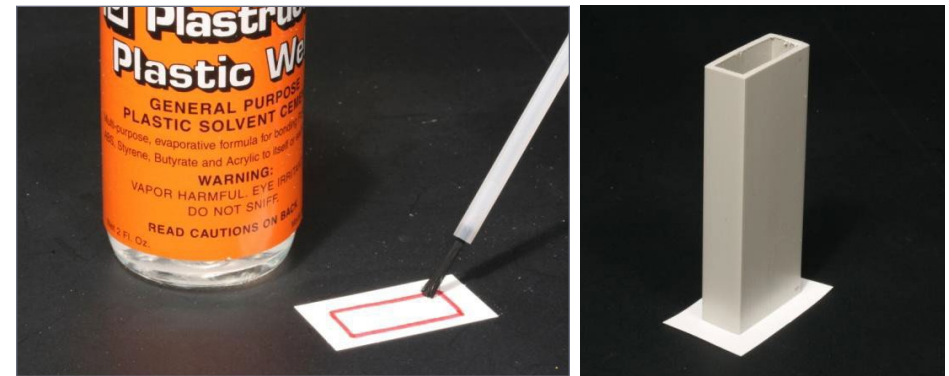

7. Plastruc Plastic Weld is excellent for bonding plastics because it melts them together forming a solid bond.

its footprint with a pencil, taking care not to gouge the thin material. Next I joined the end and body by applying a thin line of Plastruc Plastic Weld along the footprint line. I then placed the block onto the glue, keeping a firm hold until the Plastic Weld formed the bond between the two parts. When the join is complete, there may be small "melt marks" or divets showing in the thin styrene. These are acceptable since we are modeling a rough unfinished product.

I removed the excess styrene of each end section using a two-step process. I cut the excess from the large block body by standing the block on end, and using a sharp #11 blade to carefully cut around the edge. Once that rough cut was complete, it could be filed smooth using the same pink file that was used earlier. Then I sanded each side by placing the file along the long block surface, pulling it from the ends inward, then gently sanding across each end to smooth out any rough spots. Finally, I made one gentle pass along each long side, and subtly rounded the edges where the sides and ends met

## SIMPLE METAL BLOCK LOADS | 9

With the six large blocks completed, it was time to transform them from raw gray and white plastic into something looking like the metal of the prototype. I needed a coat of silver, either from an airbrush or a spray can. Painting required that I secure the group of blocks, so that they could be turned to their top, or end surfaces to be evenly coated. The underside would not be seen, so it was not necessary to paint it. An easy and inexpensive way to do this is to double-over a piece of tape so the sticky side faces out, then place this onto an old kit box. After adding several strips of tape to the kit box, I had a homemade painting jig for holding the blocks.

Having turned the raw styrene into finished product, I was ready to build up the load and mount it onto the flatcar. As

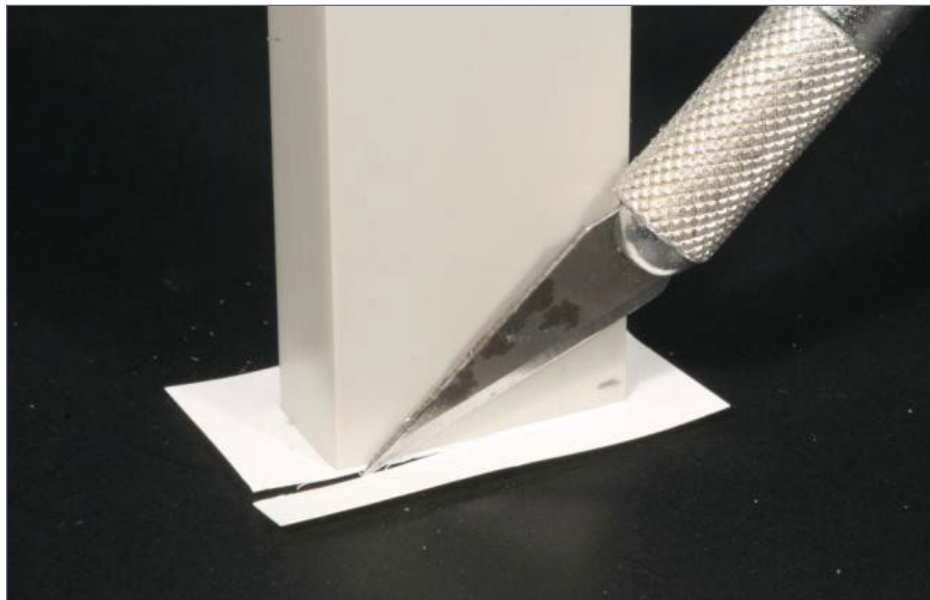

8. The excess styrene sheet can be trimmed from the end cap by tracing around the block body with a sharp #11 knife blade.

## SIMPLE METAL BLOCK LOADS | 10

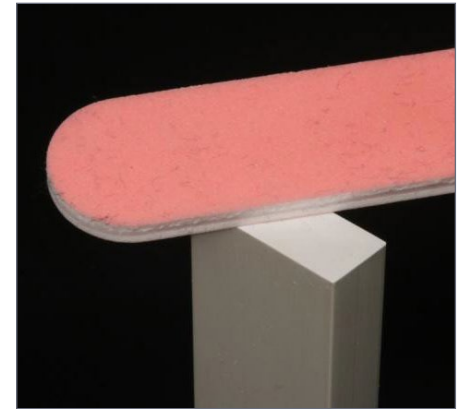
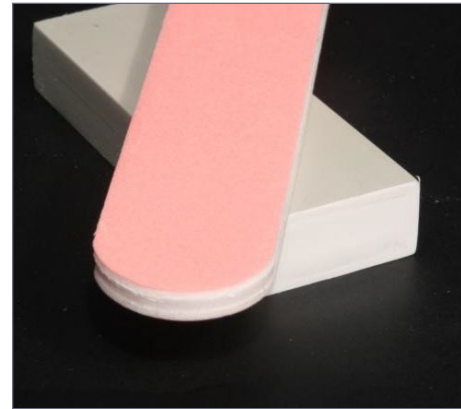

9. After trimming the excess styrene the rough edges on the sides and ends can be smoothed with a file.

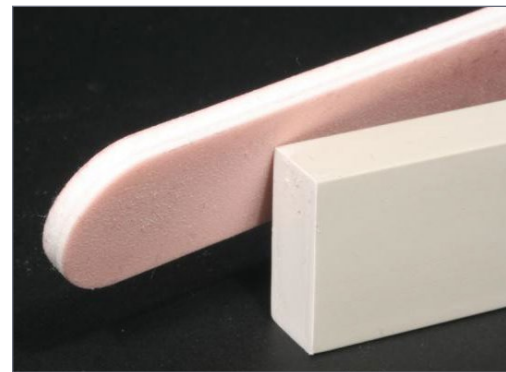

10. The “hard” corners can be easily reduced into gentle transitions by slightly rounding them.

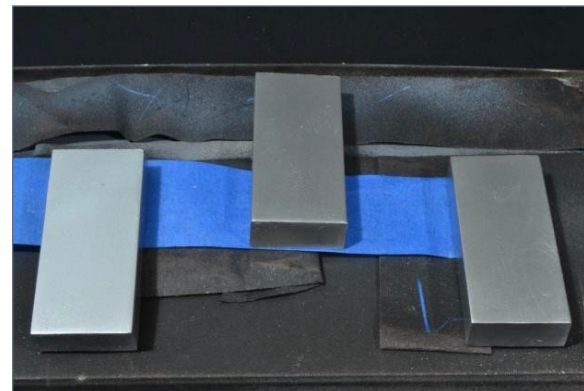

11. A homemade painting jig requires nothing more than a boxtop and several pieces of tape.

## SIMPLE METAL BLOCK LOADS | 11

the prototype photos show, the load consisted of three groups of two blocks, one stacked on top of the other, with two small wood runners in-between. I made these runners from 3" x 4" scale lumber strips (Northeastern Scale Lumber HOSCAL3411) cut to 29/32", just slightly wider than the blocks.

I cut each strip using a #17 chisel blade, then applied a thin bead of CA cement (such as Zap or Zap+) to the underside of one block, approximately 3/8" from each end. Then I placed one runner onto each bead and adjusted them as necessary until both were square to, and equal distance from, the ends of the block. I repeated this for two additional blocks. Then I joined the "top" blocks to the "bottom" blocks, using CA cement on the underside, this time along the wood runners. This will help to prevent oozing, and reduce "hazing" from excess cement.

Once I'd built the three groups of blocks, it was time to add the strapping that holds them together. Prototype photos show that the blocks were held in place by a series of straps extending from

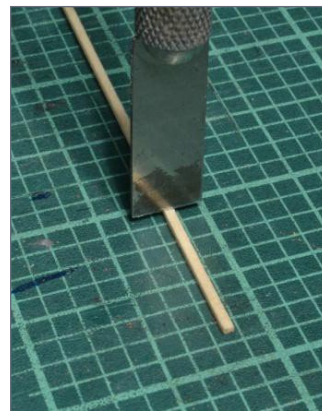

12. Each block is separated from the other by wood runners for loading and unloading. Wood runners can be easily modeled using scale lumber available in a variety of dimensions.

## SIMPLE METAL BLOCK LOADS | 12

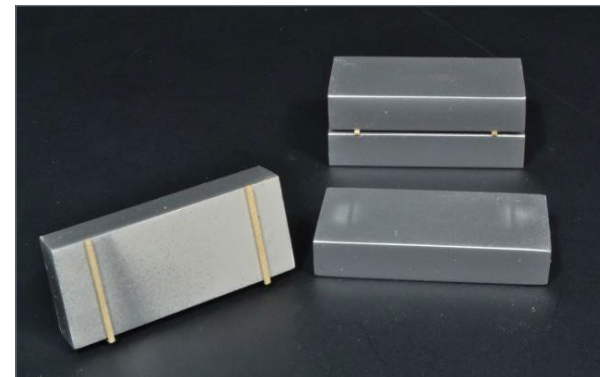
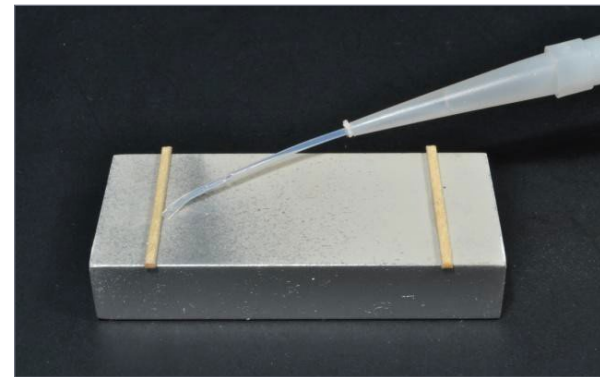

tie-downs on the car, and wrapping around the blocks. This was the most visually appealing part of this load, and was made using airplane striping tape. The 1/16" self-adhesive vinyl tape is available in multiple colors, and is excellent for modeling strapping or banding. For this project I chose Great Planes Yellow (GPMQ1420), and applied it in two steps. The first step models the straps wrapping around each group of two blocks, and the second models the straps extending down from



13. Apply the cement sparingly to the bottom of the load to prevent accidental damage.

the car sides over each group.

I began by cutting 15 sections of

14. Airplane striping tape in three colors.

## SIMPLE METAL BLOCK LOADS | 13

striping, 3-1/2" long for the five straps wrapped around each group of blocks. Next I placed the first block assembly onto a cutting mat using the embedded grid lines to center it. I then peeled the backing from the self-adhesive striping and placed the first strip across the center of the top block using the grid lines for alignment. Once I was satisfied with the placement of the "strap," I picked up the block and worked the striping tape down each side, making sure it was tight, since it represents a tie-down strap under tension. Finally, I wrapped the striping under the bottom block until it overlapped itself. Now the other four straps could be added in a similar manner, working from the outside of the block inward while using the grid lines to keep the spacing even.

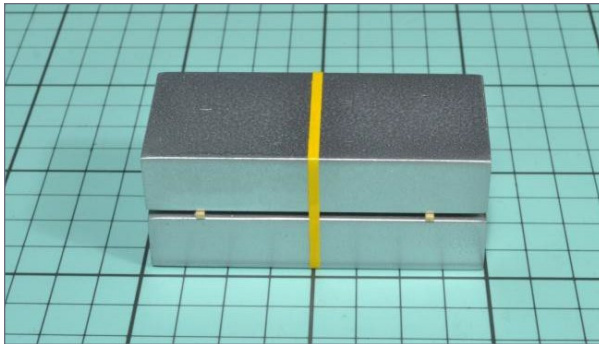

Once all the striping was added, I applied a thin bead of CA cement across the underside of the block. This made

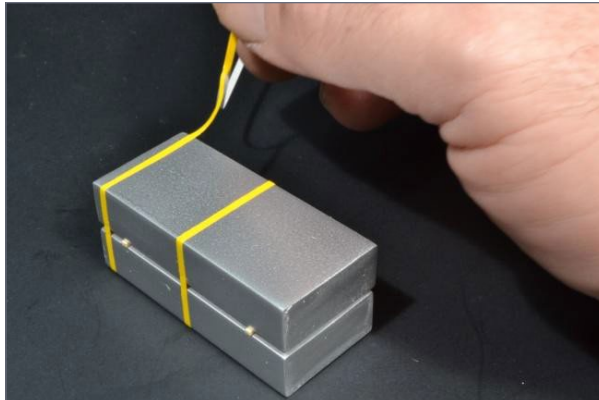

15. A cutting mat with a grid pattern is an easy way to make sure that all the striping is placed at even intervals across the blocks. Start at the center then work from the ends inward.

## SIMPLE METAL BLOCK LOADS | 14

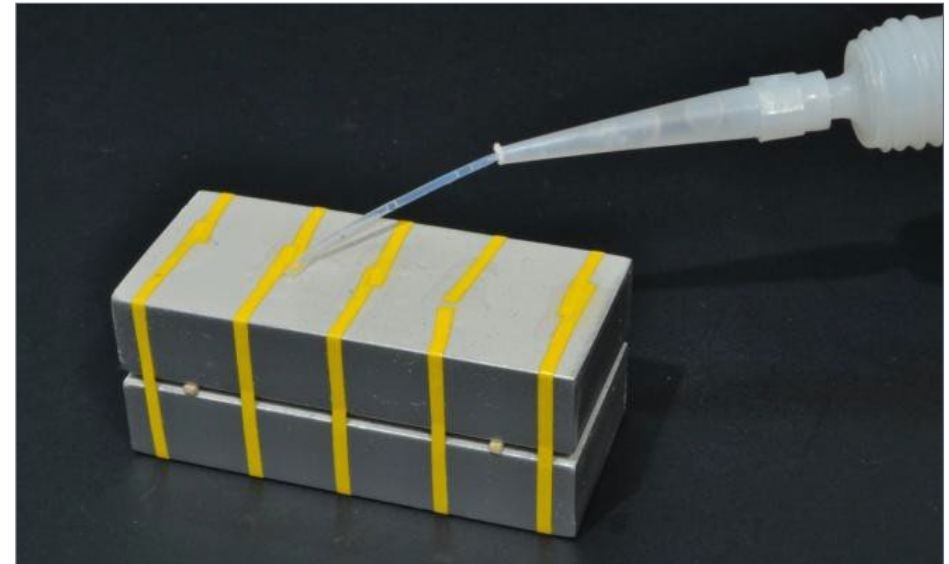

16. Once the striping is applied to each group of blocks, it is glued with CA on the underside to make it permanent.

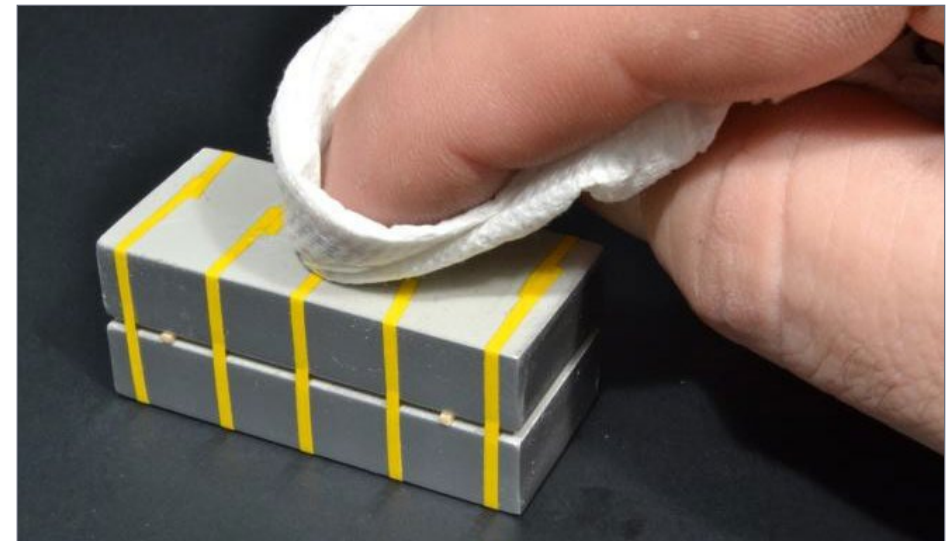

17. After the CA cement is applied, spread it with a paper towel. This will soak up any excess cement.

## SIMPLE METAL BLOCK LOADS | 15

sure that the striping would be permanent, even if the adhesive on the striping tape dried out. I applied one drop of CA to each stripe, then worked it across the surface with a paper towel. This spread the CA, flattening out the drops of cement evenly, and absorbed any excess.

Now that the load blocks were done, I could focus on the car that would be carrying them. I began by weathering the flatcar deck. Next I fabricated the runners mounted on the flatcar deck using 8" x 8" Northeastern scale wood strip (HOSCAL 6611). Most prototype cars I've seen have runners mounted on the deck at 24" intervals. In my opinion, this can cause a cluttered look on models. Rather than mirror the prototype, I used runners only below the blocks, each mounted in line with the stake pockets of the flatcar side sill.

To easily cut the 11 runners the MDC/Athearn flat would require, I taped a group of four wood strips together, then



18. Finished banded load.

## SIMPLE METAL BLOCK LOADS | 16

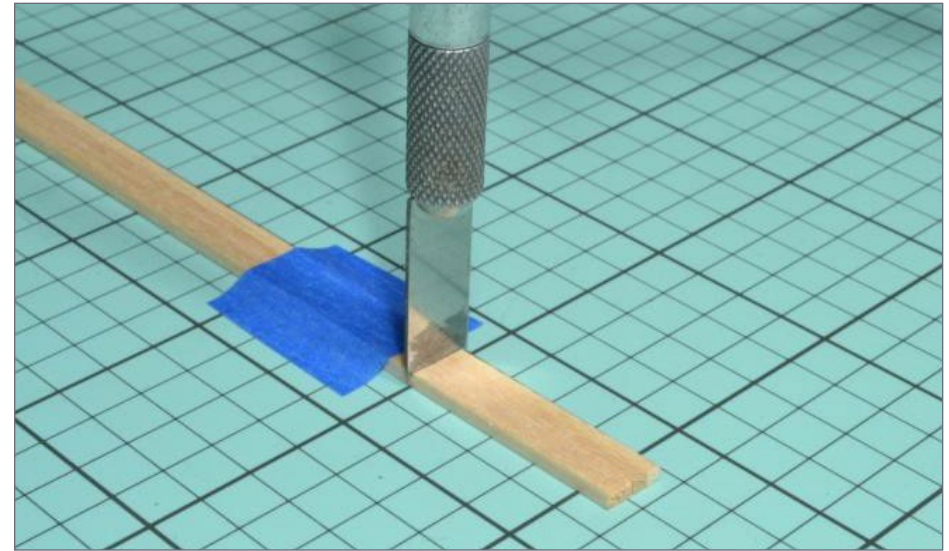

19. Multiple runners can be cut quickly by creating groups of wood strips taped together.

placed them onto a cutting mat. Using the grid lines for alignment. I trimmed the ends so all four strips were identical in length, and cut them to match the deck width using an X-Acto #17 blade. I then placed the angled side toward the long length of strips. After cutting the first batch of runners, I sanded the rough edge left by the blade on the end of each long strip. I repeated the process until all runners were the right length.

Adding a load to a flatcar is really nothing but a retrofit, and the contrast of the bright raw wood against the flatcar deck seems unrealistic and even toy-like. To remedy this, I toned down the wood runners with weathering chalk. I used the simple method of rubbing chalk onto my fingers, then rolling each runner between them, rubbing and twisting them until I had a small pile of "weathered" wood.

## SIMPLE METAL BLOCK LOADS | 17

Now the runners could be added to the flatcar deck. There is no better way to destroy a model than with glue oozes. Rather than applying CA cement to the flatcar deck or directly to the runner, I used the puddle-and-dip method. I applied several lines of CA

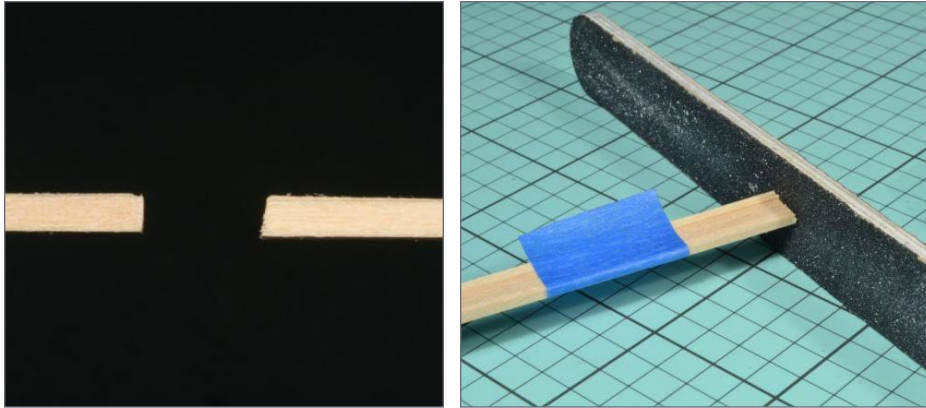

20. The flat side of the chisel blade leaves a square cut, and the angled side leaves an angled cut. This can be squared-up easily using a file along the edge.



21. Raw wood is generally very bright in contrast to a weathered model. It can be toned down quickly and easily using weathering powders.

## SIMPLE METAL BLOCK LOADS | 18

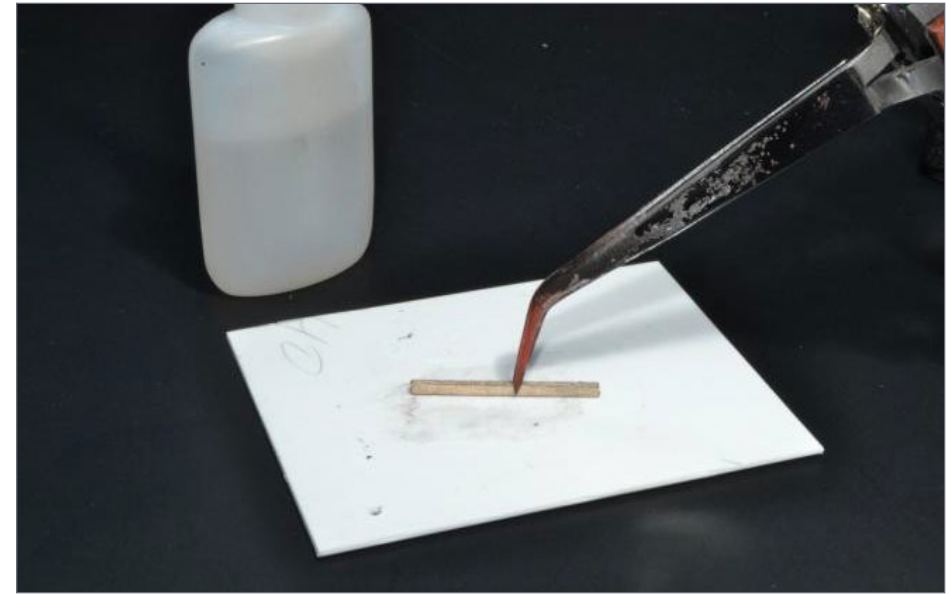

22. One method for preventing damage from glue is to use the “puddle-and-dip” method. No cement is applied directly to the part being glued.

cement onto a scrap piece of styrene, then worked these into an extremely shallow “puddle.” Holding the runner with tweezers, I dipped it into the cement puddle, allowing the cement to coat the bottom surface. Then I placed it onto the flatcar deck without ooze. If it appeared the runner picked up too much cement, I discarded it and replaced it with another.

Once the runners were mounted on the flatcar deck, I added the block assemblies. I test-fitted them first by placing them onto the runners to make sure they would sit level. High spots can be in the milled scale lumber, or as the result of the CA applied to the underside of the blocks. Either one prevents the blocks from seating evenly, which will totally destroy the illusion of multiple tons pushing down on the wood. If a high spot was found, I

## SIMPLE METAL BLOCK LOADS | 19

fixed it by dragging a #17 blade across the top of the offending runner, until everything was level. I then secured the blocks to the runners with some CA cement on the top of each runner. I took care not to allow excess cement to run down onto the flatcar deck.

Once the blocks were mounted on the flatcar, all that was left was to add the tie-down straps. One again, using the yellow

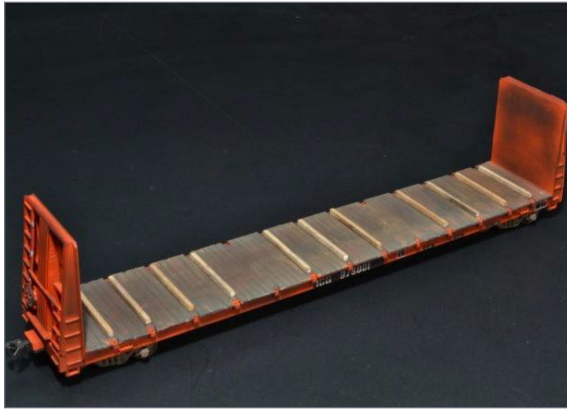

23. Any high spots found, once the runners are mounted to the flatcar deck, can be fixed by gently whittling on the soft wood of the offending runner.

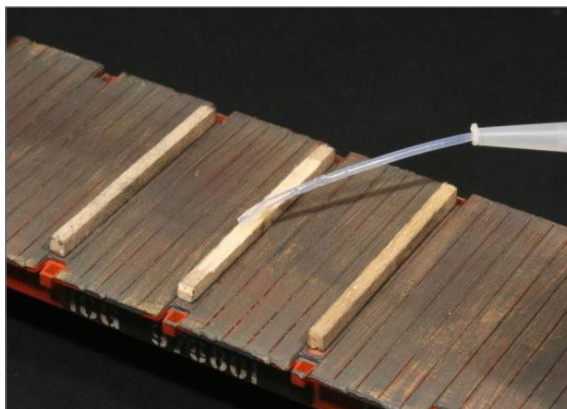
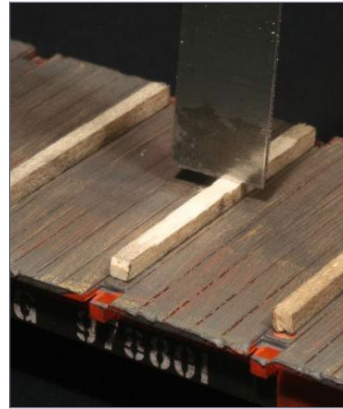

24. A gluing tip allows greater control over the flow of cement. However, the best way to prevent damaging your work is to apply glue to areas that will never be seen, such as the center portions of the runners.

## SIMPLE METAL BLOCK LOADS | 20

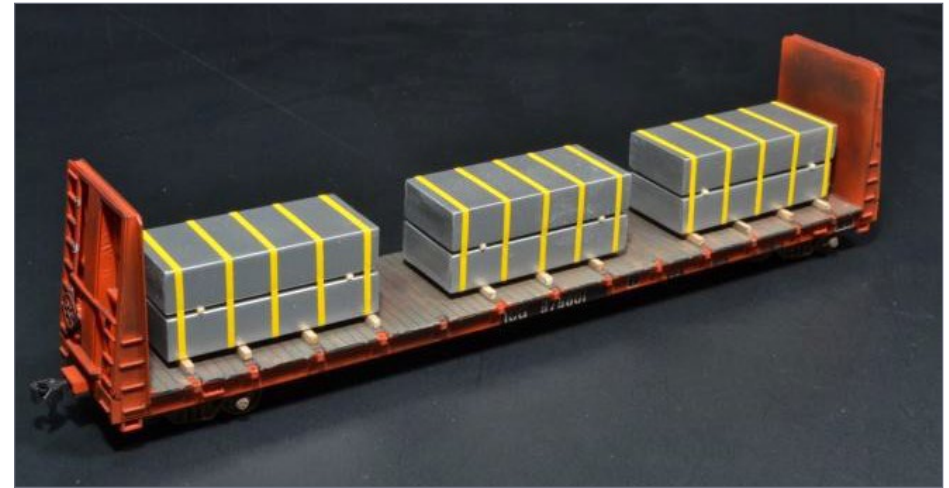

25. The finished loads, ready for tie-downs.

striping tape, I started by cutting 11 5-½” strips from the roll. The roll had plenty of tape, so wasn’t afraid to use more if I damaged a piece.

I added the first tie-down strap, extending it from the face of the first stake pocket up to the top of the stacked blocks. I used the strip’s self-stick adhesive to hold it in place on the stake pocket surface. Once I was satisfied that the strap had a straight alignment I wrapped the striping over the top of the block and down the other side, sticking it to the opposite stake pocket.

If I was not satisfied with the look, I simply removed the striping and adjusted it. If the striping was straight, I pressed it across the top of the block firmly into place, and pulled the first downward strap from the face of the stake pocket. The striping is “self-adhesive,” but a thin application of CA cement between the stake pocket and striping will make a more permanent bond. I pulled the striping tape aside, and applied the CA to the stake pocket. Then I replaced the striping tape, pulling it taut. I

## SIMPLE METAL BLOCK LOADS | 21



26. This photo shows the position of the tie-down straps. Notice how taut they are.



27. When applying the striping tape as tie-down straps, allow any extra to extend below the flatcar.

## SIMPLE METAL BLOCK LOADS | 22

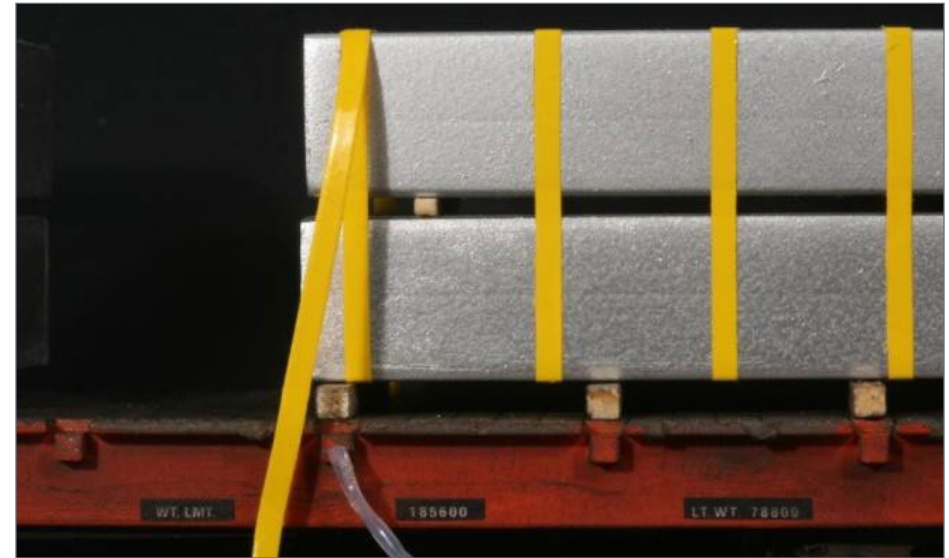

28. Once you are satisfied with the placement of the tape, pull it aside from the stake pockets and permanently glue it with CA onto the face of the stake pocket.

allowed the excess to extend below the flatcar side.

Once the CA cement was dry, I simply cut the excess striping tape from the bottom edge of the stake pocket, using a #17 chisel blade. Then I added each additional tie-down strap, completing an interesting and dynamic load that was sure to gather attention as it rolled down my rails. ☑

*Additional pictures on the next page ...*

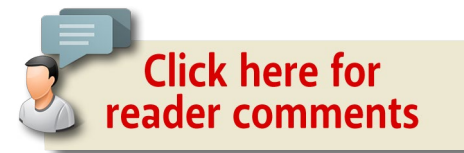



## SIMPLE METAL BLOCK LOADS | 23

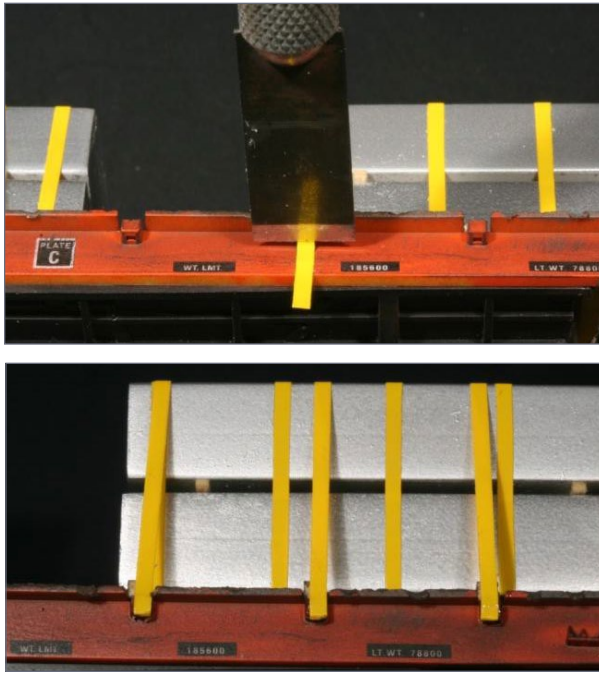

29. Once each strap is permanently glued, the excess can be cut off using a #17 blade. This leaves the appearance that these mount to the stake pockets.



30. A finished shot of the loaded flat car.

## SIMPLE METAL BLOCK LOADS | 24

### M.R. SNELL



M.R. (Matt) Snell has been a model railroader and railfan for 30 years. His interest in railroading grew while growing up in New Jersey surrounded by freight and passenger rail lines. Presently residing in Ohio, Matt and his wife Debie share the hobby, modeling the area he grew up in: north-central New Jersey.

Their “Conrail New Jersey Division” layout has been featured in *Great Model Railroads*, *Rail Model Journal*, and in the Allen Keller *Great Model Railroads* DVD series. Matt has had articles in *Railroad Model Craftsman*, *RailModel Journal*, *Scale Rails* and *Model Railroader*, as well as online at [railroad.net](http://railroad.net). ■

 [Click here for reader comments](#)



# Announcing a New Limited Run PWRS / River Point™ Vehicle!!!

Ford F-350 Series XL SRW Super Duty

**Modern Era Hi-Rail Trucks  
for Canadian Pacific (CP)**

**PWRS**

**COMING**  
September 2015



Official  
Licensed  
Product

PACIFIC WESTERN RAIL SYSTEMS  
**SPECIAL RUN CAR**

**HO**  
SCALE

CLICK HERE FOR  
**CP Hi-Rail**

**Pacific Western Rail Systems**

**Annual  
Fireworks  
Sale!!!**



**July 1st - July 8th, 2015**

CLICK  
ON THE  
FLAGS

MRHMAG.COM



Model Railroad Hobbyist | July 2015 | #65

# YES, IT'S A MODEL

compiled by  
**DON HANLEY**



**Click here for  
reader comments**



1. Terrance Boardman posted photos on the MRH forum of his Santa Fe boxcar. The boxcar is an old Roundhouse kit, as is the CSX boxcar. He thinned down the stirrups. Terrance lightly sanded the flat surfaces with 2000 grit wet-and-dry paper to reveal some of the color behind the lettering and to smooth out any blemishes. The car is weathered with a very light beige/ rust color wash to fade the red; the color is wiped off to leave a see-through coat. Light touches of rust are added to make a fantastic-looking car.

► **MRH'S MONTHLY PHOTO ALBUM**

- [TABLE OF CONTENTS](#)
- [INDEX](#)

## YES, IT'S A MODEL | 2

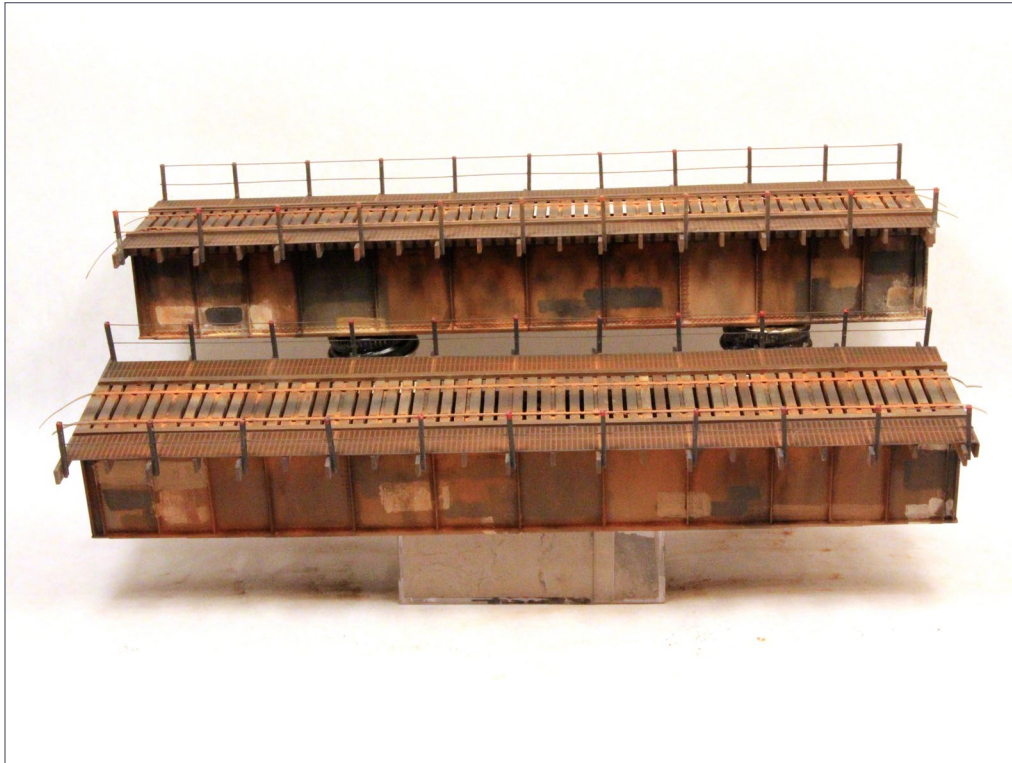

2. These Visalia Electric RR bridges have seen many years of service with little maintenance. Rick Sutton weathered two ExactRail 72-foot plate girder bridges with a light overspray of Krylon gray primer. He masked off some panels and painted them with different shades of gray (maybe not 50). He followed up with various paints and powders to create the rust. The bridge ties are painted various shades of brownish gray to match the railroad's overall appearance of deferred maintenance. The bridges are now in service on Rick's layout.

## YES, IT'S A MODEL | 3



3. Arcata & Mad River GE 44-tonners 101 and 102 haul empties to the interchange on Mitch Valder's Northwestern Pacific 1958 layout. Mitch painted the N scale Bachmann engines and applied custom decals from Highball Graphics. The working beacon lights are from Details N Scale. Brad's N Scale Station installed TCS Z2 decoders in both. The sun shades are scratchbuilt using wine bottle lead foil.



4. This is Mike Confalone's Allagash Androscoggin Subdivision at Holman Mountain. The scenery project was a two-month-long affair, and by far the most ambitious and challenging scenery project he has attempted to date. Mike used sheets of crushed Styrofoam for the melting snow, massive quantities of dirt and leaves, plus he made and planted a untold numbers of trees. The rocks are from Cripplebush Valley Models, cut and blended to fit the space and then colored and weathered with artists oil

paints and turpentine. Compare the views here to the bare plywood *BEFORE* at this location in the Allagash Ops Live 5 video ([available at the MRH Store](#))!



## YES, IT'S A MODEL | 6



## YES, IT'S A MODEL | 7



5. Gregory Wiggins has been sharing his progress on building Burditt Bros. Coal shed on his Rutland Yard blog. Look at [mrh-mag.com/node/11321?page=16](http://mrh-mag.com/node/11321?page=16). His goal was to create the Insul-brick look that was so common in the '50s and '60s. We think he hit a home run with his efforts.





6. Where did the bridge go? Someone stole it! Call dispatch and tell them the bridge is gone! No, you explain it to them! Joe Atkinson shared his progress on modeling Indian Creek on his layout. To see more of his work, go to Joe's blog at [mrhmag.com/node/22148](http://mrhmag.com/node/22148).

**\$ GET PAID FOR YOUR PHOTO**

We pay \$40 per photo we publish. If you'd like to get your modeling in our photo feature, just start posting your photos on the MRH website, especially in the Weekly Photo Fun thread created each weekend.

See [mrhmag.com/help](http://mrhmag.com/help) for more on how to post an image. You need to be an MRH subscriber to post photos to our website, and becoming a subscriber is free, [just fill out this form here](#). ■

 [Click here for reader comments](#)

**When talking to hobby vendors, please remember to mention MRH.**

# The LEWIS COUNTY MODEL RAILROAD CLUB

BY THE MRH STAFF

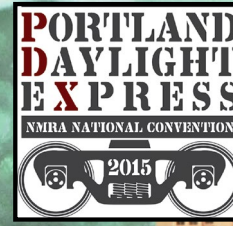

Also coming to  
TMTV in July

Modeling western Washington railroading  
in the late 20th century on the HO layout  
at the Lewis County Historical Museum ...

1. As a museum layout, the Lewis County Club strives for a freelanced but historically correct portrayal of the western Washington State region where they're located. This includes portraying actual local industries from the latter 20th century. This sawmill, with its log dump, the log pond, and the mill structures properly reflects typical Pacific Northwest logging practices.

**MRH: INTRODUCE US TO WHAT YOU'RE TRYING TO MODEL HERE.**

**Ted Livermore:** We're building an exhibit for the Lewis County Historical Museum and it's a generic version of Lewis



2. A key element of the club's mission, as part of the Lewis County museum, is to portray typical industries that actually operated in western Washington in the last half of the 20th century. Here we see a Texaco gas station and a National Frozen Foods warehouse, alongside the Centralia, WA railroad yard. Structures like these are highlights of this club's layout.

County in Washington State. It depicts from Morton, WA to the ocean, which is South Bend, WA and Raymond, WA.

We're depicting history from about 1970 to the early 1980s period, showing what was here. Of course we can't duplicate everything, so we're picking out the highlights: the best structures, the best things that people would remember. We're trying to make it educational for the students that come in and to make it as historically accurate as we can.

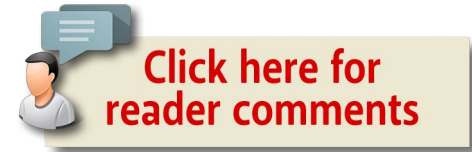

**David Bond:** Because we're trying to model the railroads of Lewis County, we're modeling most of the major cities along this part of the former NP – which is now the BNSF and the UP. We're also modeling the coast line from Chehalis out to Willapa, which was run by NP.

**MRH:** What is the mission of the museum?

**Ted:** The mission of the museum is to preserve the history of Lewis County and the history of the people in Lewis County. The museum wants to present this history in a form that makes it easy for people to learn. People can come in and do research on the history of the people, on the businesses, and on various places in the county – even research on various homes in the area.

The museum has a collection of about 25-30,000 photographs right now. We are re-cataloging the photos currently, and there's a lot there. Some pictures, for example, might show the train depot in 1915. As you look at the picture, you may see it has a milk wagon, and maybe it shows a Mogul locomotive, and then there's some passenger cars, and of course there's people – so one photo can have a lot of different subjects!

We're in the process of reclassifying all of our pictures and cross-referencing everything we can. It's quite a job!





3. The club layout resides in a museum that was originally a large Northern Pacific brick train depot in Chehalis, WA. As a public exhibit, the club needs to first be a historical exhibit the public of all ages can see, learn from, and enjoy – and then second, it’s a model railroad for the club members to enjoy.

**MRH:** What is the history of this building?

**Ted:** The building was built in 1912 and it was one of the last large depots built for the Northern Pacific.

The present depot is exactly as you would have seen it in 1912. The only things changed in here are a couple of doorways, the lighting, and the addition of air conditioning. Everything else is the way it was in 1912.

**MRH:** How important is it that things in here remain unchanged?

**Ted:** From an historical standpoint, we have a lot of people who come in just to see the building.

They’re enjoying the architecture and the type of craftsmanship used to make the building.

We have original features like terrazzo floors and brick floors – they have not been changed and they’re fairly crack-free. That’s actually somewhat surprising, given that we have some 50 to 60

“mini-earthquakes” a day here when the trains go by and believe me, you can feel them going by!

**MRH: How did the club end up here in the museum?**

**Ted:** The club’s existed for about 35 years. We were in a box car when the second-to-last member died. I was the last member left. A couple of individuals approached the museum about creating a model railroad exhibit. An advertisement was placed in the local paper announcing a meeting to discuss building the exhibit. About 25 people showed up for that meeting! Out of that number, a few of us came back for a second meeting, and that group decided to go ahead and build the layout. The group decided to organize itself under the existing club’s not-for-profit corporate charter.

**MRH: What are the challenges of building a layout in what amounts to a train station baggage room?**

**David:** The floor is not level! It’s dirty. But it gives you a great space – it’s a museum, so it’s climate controlled, which is an advantage.



4. The club layout models the NP main and also includes a freelanced version of the NP coast branch that ran to South Bend and Raymond, WA. As the coast branch neared the ocean, it was common to have spans that turn or lift to clear barge traffic on the waterways. Here, club members have modeled one such bridge in this great-looking scene.



5. A BN local freight rumbles across a truss span near the freelanced town of Littel, WA. The layout’s nicely-painted backdrop and tree-studded mountain scenery lend an appropriately Pacific Northwest feel to the layout.

**Ted:** For example, we don’t need to clean the track much here. We probably give it a thorough cleaning maybe three times a year, if that.

It stays pretty dust-free and clean because we have an environmental system in the museum. The system helps keep out the dust and maintains a constant temperature. It does not fluctuate more than about 4 degrees throughout the year – that makes it really nice, especially for things like laying track.

**MRH: When can people come see this layout?**

**David:** The museum is open this time of year from ten until four, Tuesday through Saturday. During the summer it’s open for

a little bit longer hours, I believe it’s ten until five – but again it’s Tuesdays through Saturdays.

**MRH: How important is this place to the community?**

**David:** This museum has a rather low attendance. I think having the model railroad here has brought more people in. When we have open houses, we get a lot of people through here – it makes them aware the museum is here.

Years before there was a model railroad club in here, I would drive by the place and say to myself, “I’m not really interested in going in there – what’s in there to see – what’s in there to do?”

With this club layout here, now there’s something that I would go see in this museum!

**MRH: So you have a dual purpose of serving the community as well as the hobby interests of the members?**

**Ted:** Yes, it’s an educational layout for the visitors. We do have a lot of animation on here to help them learn the history of the area. For the club, it gives us a place to meet, a place to perfect our hobby and modeling skills.

I might add that the club pays for everything here on the layout. The museum doesn’t pay for anything – it’s an exhibit we are donating to the community. We maintain it and we fund it through train shows, swap meets, and what have you.

While we do pay for everything here on the layout, it all belongs to the museum and they keep it if we ever leave. There are some things that don’t belong to museum, like the rolling stock, the vehicles, and a few buildings that have our name on them, but that’s it.

It's great for us because we don't have to pay insurance, we don't pay rent, and we don't pay utilities. If we go to have a train show or open house we're covered because it's under the museum's policy.

### **MRH: What has been the response from the public so far?**

**David:** They really like it, especially the kids. Even when we're not operating the layout, we have display loops on both sides and they can push the buttons to get trains to run. The kids run back-and-forth pushing the button, making the trains run by themselves.

**Ted:** This is also a great place for people interested in the hobby to come and learn. We have new members in the club who are just learning the hobby. We even have junior members and it's great to see the junior guys stepping up!

### **MRH: So for both kids and adults, what are they learning from seeing the layout?**

**David:** They're learning the history of the railroads that ran through Lewis County. It's hopefully introducing them to model railroading. We've finally gotten a new member in here that's not retired or almost retired! Our newest member is still in high school.

**Ted:** Yes, they're definitely learning about model railroading itself. Many don't realize what's available because we don't have local hobby shops, so they don't get to see what's available "out there." So they see it from us – plus they learn what can be done with the different facets of the hobby.

There's not only the building of the layout, there's the architecture and historical end of it, there's the electrical end of it, and there's



6. More precisely, the club models the 1970s and the 1980s on this former NP line that became part of the Burlington Northern system on March 2, 1970. It wasn't uncommon to see Great Northern equipment such as the caboose on the trestle running through. The Milwaukee Road train running under the trestle is running on Milwaukee track that went through Centralia, Chehalis and on out to Raymond, WA.

the scenery end of it. We're starting to bring the younger generation in that are tuned into the computers. It's good to see that we're a valuable educational tool.

### **MRH: Who is enjoying it the most?**

**Ted:** Oh we are! Isn't that why you retire, so you can play with your trains? Seriously, we like the history and we just love the



7. One part of the club layout models industries seen more often in the interior of Washington State, such as a logging operation or a gravel pit as shown here. The empty Weyerhaeuser log train is heading up into the Cascades toward the lumber camp to get another load of logs for the big sawmill on the coast branch.

trains. Myself, I love to build or scratchbuild a lot of the items on the layout, as have some of the other members. It's just something you love to do – that's why it's a great hobby.

**MRH:** Doesn't trying to meet the competing interests restrict what you can do with the club?

**David:** No, I think our club is no more restricted than we want it to be. We want to be open, friendly, not telling people what they couldn't do, we're more into telling you what you can do.

The only time we have any "restrictions" is if we're having an open

house and then we're restricted to the railroads that ran through Lewis County, Washington. We have had one person who would like to run CSX. Other than that, we have some Southern Pacific people, and we have some Cotton Belt, but we mainly like to run the railroads from here.

**MRH:** Do you run the railroad differently when you're by yourselves, versus when the museum is open and you have to play to an audience?

**David:** When we're here by ourselves we typically run switch lists. When the doors open for the public, we normally just run trains around to have motion and action on the layout.

**MRH:** How do you protect things from little fingers and what are these buttons on the front of the display area?

**Ted:** Well, the buttons on the front are the start of our animation. Right now we have one animated display. The rest are lights. The lights highlight or light up an area and right next to the button is a sign telling you what that area is for.

One example talks about the oil distributor, another about Christmas trees that are a major part of agriculture here. Another tells more about the depots. We're planning to add more – we're trying to make this as educational as possible – and also entertaining.



8. As a BN through freight roars by, it looks like there's a wedding just now getting out at the Winlock, WA church – complete with the “just married” decorated car positioned near the door for a fast getaway. Scenes such as this add life to the layout and delight museum visitors.



We have two loops here that the public can operate via pushbutton and they love it! We have the adults pushing the buttons as much as the kids. They love to push a button and then watch the train run – it brings out the kid in all of us!

**MRH: Can you give an overview of different areas of the layout?**

**Ted:** We have the mountain division, which takes in Morton and the logging industry. We have the two main towns, Centralia and Chehalis. We have the industrial park, which shows the Railworks and the Weyerhaeuser Company.

Next, we have the line that goes out to the ocean to South Bend and Raymond, and it depicts the different towns along the way. Right in the middle we have the sawmill, which depicts a typical sawmill of the time.

9. This panoramic view shows the heavy-duty gantry facility of Chehalis Railcar. The club's attention to detail with their modeling skill makes this layout fun to tour for both modelers and museum guests.

**MRH: How did you develop the track plan?**

**Ted:** We just sat down as a group – which was four of us at the time – and decided what we wanted for a display layout. Number one, the layout was to be seen by the public. You had to be able to stand in one spot and see the layout from front to back and from side to side. They needed to be able to take in the whole thing standing in one spot.

We needed the layout height to be such that the little kids and kids in strollers and so on could see the front of the layout. The



10. Taking a closer look at the details of the big lumber mill operation on the coast branch, first is the log dump here. The crane picks up the logs and then drops them on the wooden bunk, allowing them to roll on into the pond. That murky, bark-strewn log pond water is just perfect!





11. Next, is this close-up of the lumber mill's curved-roof loading area. This curved truss roof construction was quite common for lumber mills located in the Pacific Northwest.

To anyone from the Northwest, this just shouts "lumber mill" right away.



12. Looks like there's an NP steam excursion running out of the Winlock, WA station today! Running vintage steam as an excursion is one way to stay era-correct, yet get in the fun of running steam on the layout.

layout, going from the front to the back, goes up in height. That allows visitors to get a clear view of the entire layout. Luckily, Dave was doing it on computer, so it was easy to change.

**David:** I was trying to maximize the running distance. We didn't want to have just a loop of track, we wanted it to be interesting. I like to minimize straight lines if at all possible. It's kind of hard with these prototypes, though. I came up with the mainline to start with, then we designed the rest of it after we did the mainline.



13. It appears there's a thunderstorm brewing in the mountains above the lumber camp! This is the terminus of the freelanced lumber branch (supposedly) outside of Morton. While freelanced, what's depicted here is typical of western Washington logging railroads in the latter half of the 20th century, particularly around mid-century.

**MRH:** Did the track plan go through a lot of iterations?

**David:** Actually, I was surprised. We had our first meeting and about two to three weeks later I came back with the basic mainline design.

So then I said, "Well, how do you like this?"

They said, "Oh, that's great, let's just go with it." So it ended up being built that way.



14. This peninsula features a Weyerhaeuser specialty-lumber operation. Again, note the curved truss building construction on the older building, shouting “lumber mill” to locals familiar with the area. Also note the newer addition to the facility in the back of this scene, with the more modern industrial metal-siding construction, also typical of lumber mills still operating at the end of the 20th century.

**MRH:** How did you develop the right height for the layout given your public display requirements?

**Ted:** We started with the front and what we literally did was we measured the height of kids in a stroller to see what their eye level was. We wanted them and the other little kids to see the layout without having to stand up on a platform. But with the layout that low, it’s hard for us to get underneath it – we’ve got a lot of aching backs from that!

Remember, the whole idea behind this layout is that it’s for the public, not just for us. If we were only doing this for us as modelers, we would build it differently. Everything would be up at 40 inches or whatever. But we wanted it down where the public would enjoy it the most.

**David:** As a public display, we’re required to support the ADA laws. It has to be accessible to the public, which includes people in wheelchairs who want to view it. We have a lot of children who come in, so we had to make sure the height was low enough to see the layout without them needing to be held up to see it.

**MRH:** About how many feet of mainline do you have here?

**David:** Never calculated it. The space is about 14 x 52 feet. We’ve tried to maximize track so we could have longer runs. So it’s a substantial amount, I’d say it’s four to five hundred feet.

**MRH:** What is the minimum radius on the main?

**David:** It’s 30 inches on the main and on the branch lines it’s 24.

**MRH:** When did you start construction?

**David:** I don’t remember exactly, I think it was May, 2006.

**MRH:** Has construction gone as fast as expected?

**David:** It’s actually been faster than I thought it would be. There was a push to get something built for the public to view,

so that the museum would feel we were providing something to the public.

**Ted:** First thing we did was put a loop in the front so we could get some trains running for the public. We put some generic scenery in. That way the public could see something. We went from there and continued to refine it.

**David:** We probably didn't do the quality job some of us would've liked with that initial work. We're going back now and upgrading those earliest areas.

**MRH:** What would you say have been your greatest challenges with this layout?

**Ted:** Getting enough people to help! Oh, there's been plenty of challenges, but they've all been fun challenges. Things like trying to decide the proper industries to put on the layout and how we're going to do those industries. We have to shrink everything down and take artistic license, yet keep the proper flavor of the particular industry we're trying to depict.

**MRH:** What do you like most about this layout?

**David:** I like the people. I like being able to come down every week. We may want to build or not. We may run trains, or we may just talk. It's a good place to meet with people that all get along with each other.

**Ted:** I really like the fellowship we have here, where we can work together. We have a common bond and we share a common interest. Plus I really love operating it!



15. The layout features a nice mix of in-town scenes and rural between-town scenes such as this one. The mountain scenes feature a good number of conifer trees, which are quite common west of the Cascades in Washington and Oregon.

**MRH:** What do you like the least?

**David:** I think it's like with every model railroad: it's too big and it's not big enough. It's like with the new section that we're building, every time we turn around, we need a little bit more space and we don't have it.

**Ted:** It is not finished! It is too small – they are never big enough. And like most layouts, we do have a few areas that we would like to change.



16. Another industry common in rural areas of the Pacific Northwest are Christmas tree farms. Here the club depicts a small mountain valley ranch that includes just such a tree farm.

**MRH:** If you did it over again, what would you do differently?

**David:** I think the front would have fewer tracks. It's like four tracks wide. We might have made it double track instead of a single track mainline. But other than that, I think it's turned out pretty good.

**Ted:** I'd like to have more walk-ins and longer runs instead of all the little peninsulas. I would make the track just go back-and-forth a couple of times. But then again, how would we make that work for the public?

Basically, we love the layout and the design. I can say it's a fun one to switch!

**MRH:** What type of control system do you use?

**David:** We're using Digitrax and we're using JMRI with Wi-Fi throttles. We also have radio throttles and we're running Railroad & Co software.

**MRH:** Why Digitrax?

**David:** It was the only DCC system that really supported signaling and that was one of the requirements for building the layout.

**MRH:** Do you have a signaling system?

**David:** Yes the mainline is fully signaled and it's bidirectional.

**MRH:** What kind of decoders are you using?

**Ted:** We're using mostly Digitrax and NCE.

**MRH:** What's your least favorite part of doing a layout and how do you motivate people to do it anyway?

**David:** My least favorite is scenery. We're lucky that we have several people in the club who are good at scenery and don't mind doing it.

How do we motivate people? People do what they want here. We try to get people to build trees – we try to get people to participate in everything. But people tend to focus on what they do best and what they like to do.

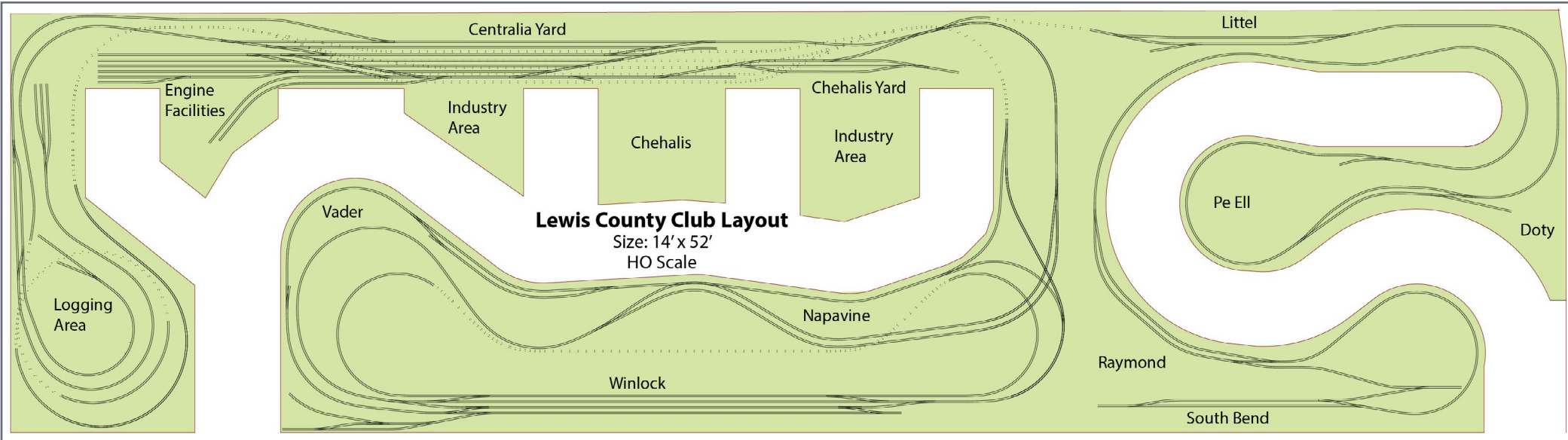

## LEWIS COUNTY CLUB LAYOUT HO SCALE

14' x 52'

*Museum guests view the layout from this direction*

**MRH:** You host operating sessions here – how are they working out for you?

**David:** They're pretty good! They're open to the public: if anyone wants to come run with us, the sessions are the third Friday of every month. We run with JMRI switch lists and it all works fine.

**Ted:** The sessions start about three or 4 o'clock in the afternoon and go 'till about 7:00 or 7:30 pm and they're great! Besides the JMRI switch lists, we also run with the signal control. We're really having fun now – we have things fine-tuned!

**In this month's subscriber bonus downloads, get an infinitely zoomable track plan and additional photos of the Lewis County model railroad club.**

[Visit bonus downloads now!](#)

**MRH:** Would you ever consider doing a layout in a different scale or gauge than HO standard gauge?

**David:** I personally like HO – it's a nice balance between the amount of detail and the amount of space required. If I had my choice, I would prefer to do narrow gauge, but that's really a minority interest.

**Ted:** I am mainly HO and I have HO at home. But I also have two-rail O scale at home and I have an N scale layout that I just built to take to shows. The N scale layout is a replica of the original John Allen layout – the original was about 5 x 7.



17. Playing to the public means the club also puts in a few fun goodies for the little kids, such as this mishap with Thomas the Tank at a pier on the coast branch. Wonder how many sharp-eyed folks catch this?

Boy, that track plan was a challenge! But I've always wanted to build it, so I built it.

**MRH:** What is your philosophy on doing a club layout well?

**Ted:** The first thing is you need to have fun – you have to enjoy it! Here, we have a basic pattern: it has to be historic and it has to be Lewis County. That sets our parameters. From there, we pick an industry we want and then vote on it. But the most important thing is we need to have fun at it! If you're not having fun at it, then don't do it – this is not a job!

**David:** I think you need to have someone with a vision, and you need to have people who are willing to accept that vision. You must encourage people to do the best they can.

**MRH:** What advice would you give to someone who's just starting out in the hobby?

**David:** I would say find other people who are in the hobby and learn from them. Read a lot, look at the magazines, read books, go

online. There are lots of people out there to help if you really want to do the hobby.

Yes, you can be an armchair railroader for a long time, but just get started doing and expect to learn as you go. It's not going to be perfect the first time. You will learn over time.

**Ted:** To start out, put a loop of track down and keep it running so you always have something to run on.

Then go visit different layouts and clubs, learn what you can learn – and find out what you're interested in.

When we get new folks here who want to join the club, we first have them come in for a month or two and play with things for a while. We want them to learn about us and to learn about what we're trying to do. If they like it, then they can join. They don't have to be an expert, they can be a beginner.

The most important thing is we want them to have fun and be compatible with the group.



You can see the Lewis County club layout at the Portland NMRA Convention this August!



Also coming to TMTV in July





MEET THE LEWIS COUNTY CLUB MEMBERS!

1. Ted Livermore
2. David Hiles
3. Warren Hambruch
4. Cal Curow
5. Neal Thomas
6. Robert Case
7. Richard Loop
8. David Bond
9. Peter Lofgren
10. Kevin Miller
11. Sam McReynolds

**DID YOU KNOW  
MRH SUBSCRIBERS  
GET FREE BONUSES?**

**CLICK TO SUBSCRIBE  
NOW - IT'S FREE!**

**WHAT'S NEW!**  
ON  
**TRAINMASTERS.TV**



**SHAUN TOMAN'S UP IN OREGON**

Visit one great small HO layout in a garden shed: see Shaun Toman's UP Oregon Division in operation.

**Non-members: Watch for just \$1.49!**



**TRACKSIDE SCENERY**

Trevor Marshall demos his trackside scenery techniques as his friend Chris Abbott follows along.

**Non-members: Watch for just \$1.49!**



**SUPER-DETAILED STRUCTURES**

Don Railton shows his techniques for creating amazingly-detailed structure models.

**Non-members: Watch for just \$1.49!**



**ROOTS OF THE HOBBY**

TrainMasters TV learns about antique tinplate trains and the origins of scale model railroading.

**Non-members: Watch for just \$1.49!**

**Watch these videos on TrainMasters.TV**

(Non-members can now watch one of these videos for just \$1.49, or download-to-own for \$3.49)





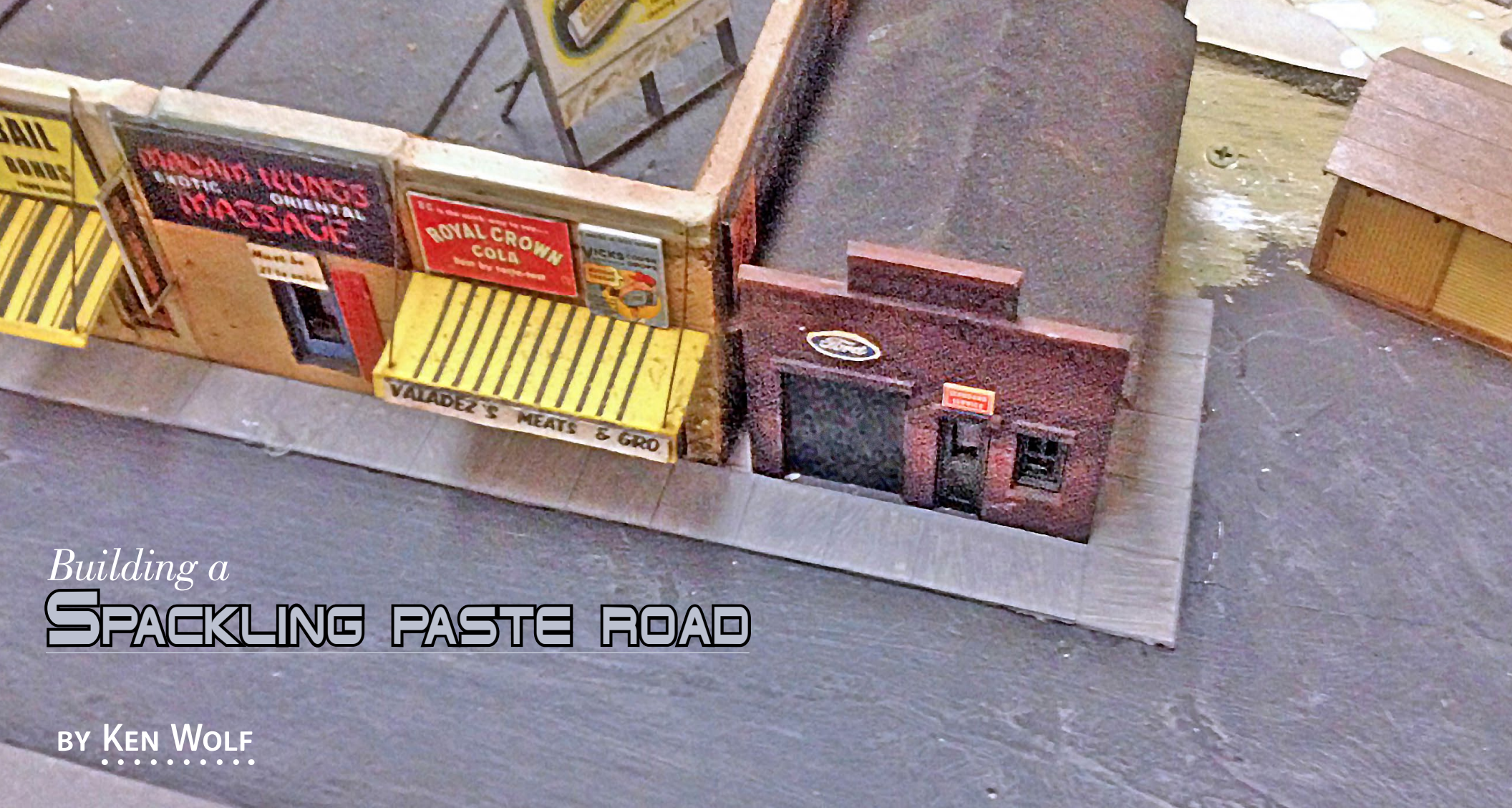

## Building a **SPACKLING PASTE ROAD**

BY **KEN WOLF**  
.....

### ***Building a road with spackling paste and a putty knife ...***

**THERE ARE MANY METHODS AND MATERIALS** used for building roads on model railroad layouts. You can buy pre-made roads in rolls, build them with styrene or cardstock, or you can use other materials that you are comfortable with. Your

choices may depend on the type of road wanted, your comfort level with modeling and the purpose of the road on the layout.

We will use spackling paste in the construction of this road. Spackling paste is inexpensive and very versatile. Our model is set in the steam to diesel transition period of the early '50s. The road to be modeled is in a small downtown area. It is a fairly simple arrangement, and we want the look of a slightly worn, but not new, asphalt road. ☑



1. The first step is to lay out the buildings you are planning to use. One of the buildings had a sidewalk molded in, so we will use this molding to define the size of the sidewalks we build.

 [Click here for reader comments](#)



2. Once the buildings are laid out, take a black Sharpie pen and draw where you want the road to be. As you can see, the corner building has a molded sidewalk and steps. Carefully draw around this structure, so that it will butt neatly up against the asphalt when finished.

## SPACKLING PASTE ROAD | 5



3. We will use all-purpose spackling paste from the hardware or home supply store, and an old putty knife. The all-purpose spackle dries overnight but can be worked for a fair amount of time. The putty knife doesn't have to be pretty, but needs to have a straight edge so the road levels out.

## SPACKLING PASTE ROAD | 6



4. Here is the road after the first application of spackle. You can see that we did go outside the lines in places, but don't worry about that. You can use your finger to remove any spackling you don't want. Try to get the coverage as level and uniform as possible. You can see in the photo the road is very white, and sometimes holes are hard to see. We will apply a second coat, so getting it perfect the first time is not critical.

## SPACKLING PASTE ROAD | 7



5. After the spackling has dried, take a sanding block. Use the finer side to sand down the road. This will knock off high spots and expose holes in the first layer. Once you have sanded it, wipe off the dust with a damp sponge, then apply a second coat. Take some care to get it level and fill holes in the first layer.

## SPACKLING PASTE ROAD | 8



6. My wife's Dyson wall unit works well to vacuum up the excess spackling dust after sanding. A regular shop vacuum will work just as well. After the second coat, make sure you sand it again and vacuum up the dust and loose bits before painting.



7. Now comes the fun part. You can use tempera paint from the craft store. It is inexpensive and cleans up with water. I also use disposable cheap brushes. Mix the paint for the first coat, a gray color. Make it lighter than you think it needs to be.



8. After the first coat, the road will look way too black. We will want to really “gray up” this road to make it look well-used. Only freshly laid asphalt would look this black.



9. Mix very light gray paint. Start with a few drops of black paint in some white. Then dry-brush the color on. This gives the road a weathered, well-used look. Use your finger to smooth and blend the dry brushing as needed. Always remember that you want to move the paint in the direction the traffic flows. Notice, the holes that the second coat filled are highlighted with the dry brush. These look like pothole patches, and are appropriate for this type of road.

10 (next photo). Once the road is painted and ready, you will want to add some sidewalks where appropriate. Where there are to be no sidewalks, don't worry about the color or plaster outside of the road's edge. The ground cover will hide mistakes. To make sidewalks, thick illustration board is

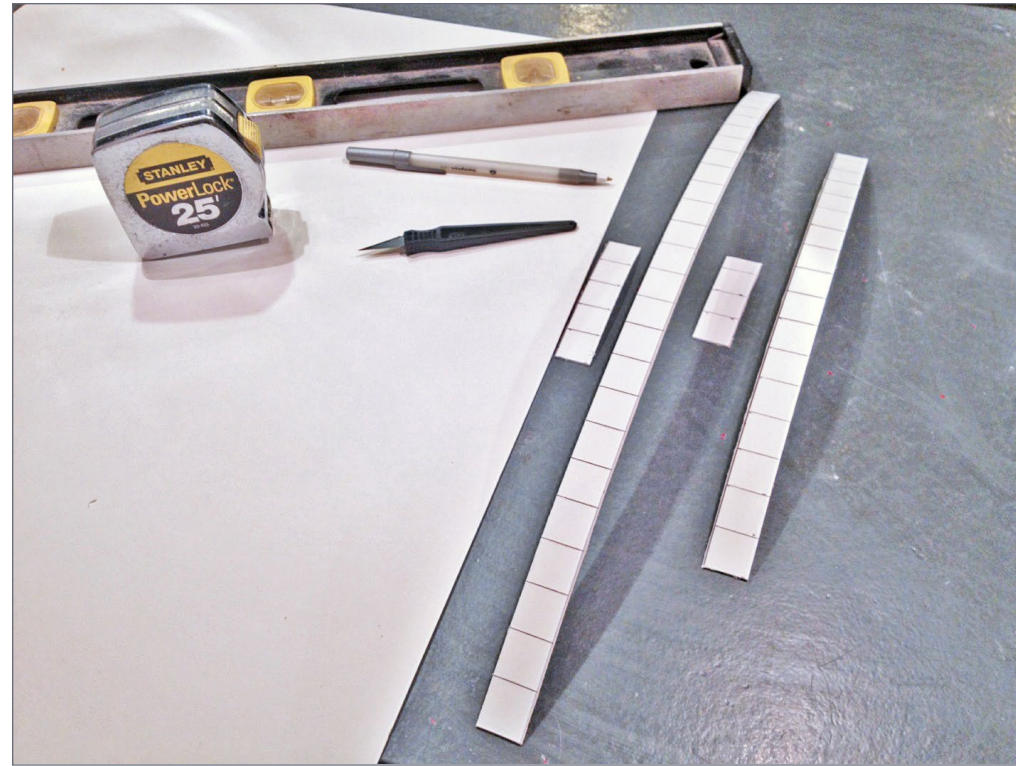

about the correct height of a sidewalk for a small town. Taller sidewalks can be made by doubling up the thickness. In HO,  $\frac{3}{4}$  inch is a good size for the sidewalk squares. A large city's sidewalk would be wider. Use what looks good in your application. Look around where you live. Some sidewalks are barely wide enough for one person, and some are as wide as a road. There is no right or wrong size.

Draw a line  $\frac{3}{4}$  inch from the edge. Then draw right angle lines every  $\frac{3}{4}$  inch for the expansion joints. Use a hobby knife to score and cut the width. Use the same knife to score the expansion joints, but not cut through. We like the three-dimensional look this gives. Try bending the expansion joints just a bit to add dimension to them. That is why the sidewalks bow in the photo.

## SPACKLING PASTE ROAD | 13



11. Paint the sidewalks with tempera paint. Make them a light gray. Again, look at sidewalks in the area you are modeling. Paint at a right angle to the street, and add several light coats until you like the look. You can highlight the expansion joints with a pencil once the paint dries. Don't forget to paint the edges of the sidewalk.

You can score in curbs when you cut the sidewalk. I prefer a scored look. In this application we did not use curbs.

The sidewalks are weighted down while they dry. Apply white glue to the back, spread it evenly, and place them in position. Replace the buildings, and then line the sidewalks up and glue them. Place the weights so that the sidewalk is in contact with the street side, so you do not get gaps.

## SPACKLING PASTE ROAD | 14

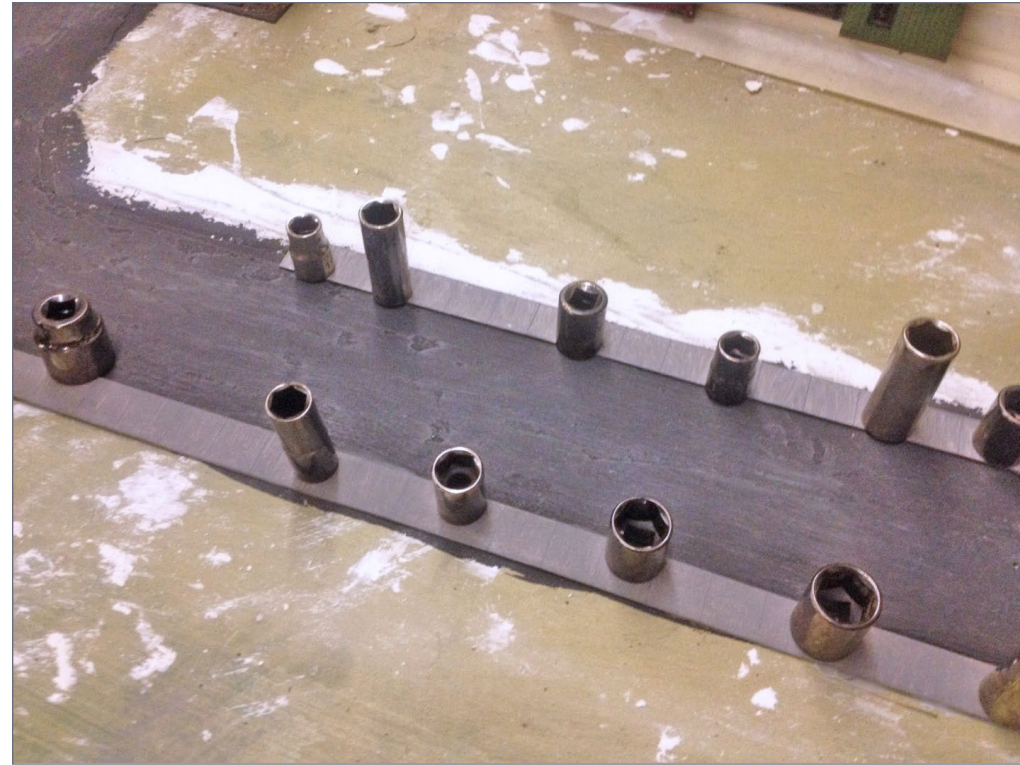

12. Once the sidewalks are placed, remove the buildings so the glue doesn't bind them to the sidewalk. If any glue squeezes out, use your finger to rub it into the street. It will look like wet or stained pavement, or you can cover it later with a paint touch-up.

## SPACKLING PASTE ROAD | 15



13. Here is the semi-finished result. Once ground cover is applied and other details like signs are placed, the scene will look fantastic. You can also daub or dry-brush some gloss black in the streets for oil stains. Just remember that less is more in most things modeled. ☑



[Click here for reader comments](#)

## SPACKLING PASTE ROAD | 16

### KEN WOLF



Ken is 55, and a vice president of a small sales and service company. He has been involved in model railroading since the age of 8. Ken grew up in Arizona and has lived in Texas, Oregon and Massachusetts. His modeling prototype is Union Pacific during the steam transition era, but he has recently incorporated New Haven into his collection. He is working on his fourth layout, and is experimenting with different techniques and building tips. The layout has four separate modules that feature a different technique on each module.

Ken is married, with three grown children and five grandchildren. He also enjoys sailing and fishing. ■

Want to help  
keep MRH free?  
Then click on  
Ads!





## MID-ATLANTIC RPM MEET

*A snapshot of coming attractions*

BY JOHN HUNTZINGER

*An exciting meet that should draw many...*

Last year's Mid-Atlantic RPM meet was great – and this year's meet will be here before we know it. It's September 25-26, 2015 in Fredericksburg, Virginia.

Here's a review of last year's meet to give you an idea what to expect this year. — John Huntzinger

**THE 2ND ANNUAL MID-ATLANTIC RAILROAD** Prototype Modeler's Meet (MARPM) in 2014 was held in mid-September at the Wingate by Wyndham in Fredericksburg, VA. This meet in only its second year was a two-day event which featured outstanding clinics, vendors, attendee model displays, hands-on weathering, styrene scratchbuilding and micro-LED seminars,

and was preceded by an Ops Session on Thursday, September 11th.



Over 110 modelers from the U.S. and Canada, with the majority coming from the mid-Atlantic area of the U.S., attended. About 15 attendees brought over 200 models for display, primarily in HO scale. Motive power and rolling stock dominated but some structures and at least four dioramas were on display.

Like other RPMs there are no contests, but attendees brought finished and in-progress work to share their work and discuss with fellow modelers.

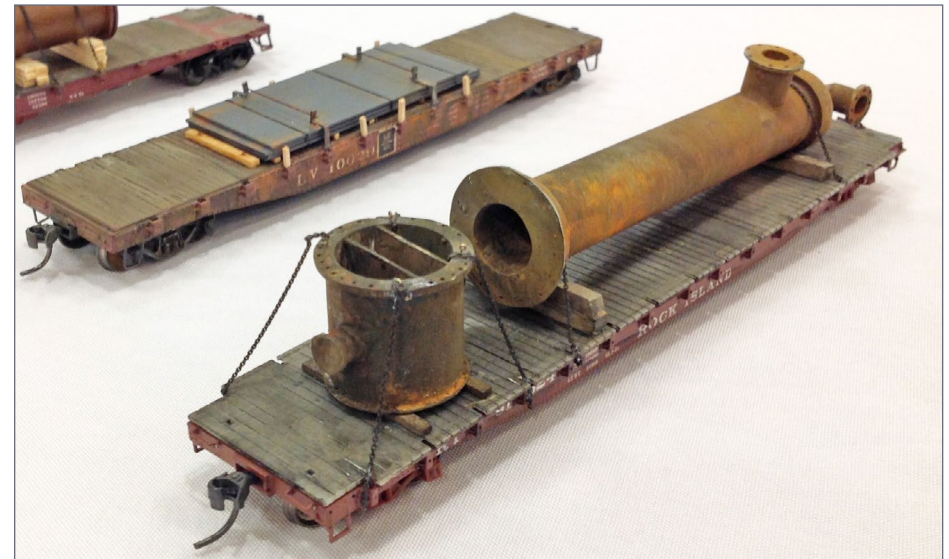

1. (Lead photo) Mike Baker's maintenance of way tamper as described in his clinic.
2. Scratchbuilt styrene loads described in Ralph DeBlasi's clinic.

SEP 6, 1956 OCRR CALL BOARD

DISPATCHER	STEVE		
OPERATOR			
HOYT STREET	BOB, SHAWN, PETE		
CLATSKANIE			
ASTORIA	JOHN, MARIE		
DEPOE BAY	Tom, HERB		
TRAIN	TIME OUT	CREW	TIME IN
11		GEORGE	
X51W		CHUCK	
350		ROY	
311		PHIL	
X4501E		HERB	
X42W		GEORGE	
X42E		GEORGE	
X161W		PHIL	
X51E		CHUCK	
351		ROY	
310		STEVE	
10		CHUCK	
123			
352			
315			
353			
314			
124			

3. Call board for the September 11th ops session on Matt Thompson's Oregon Coast Railway.

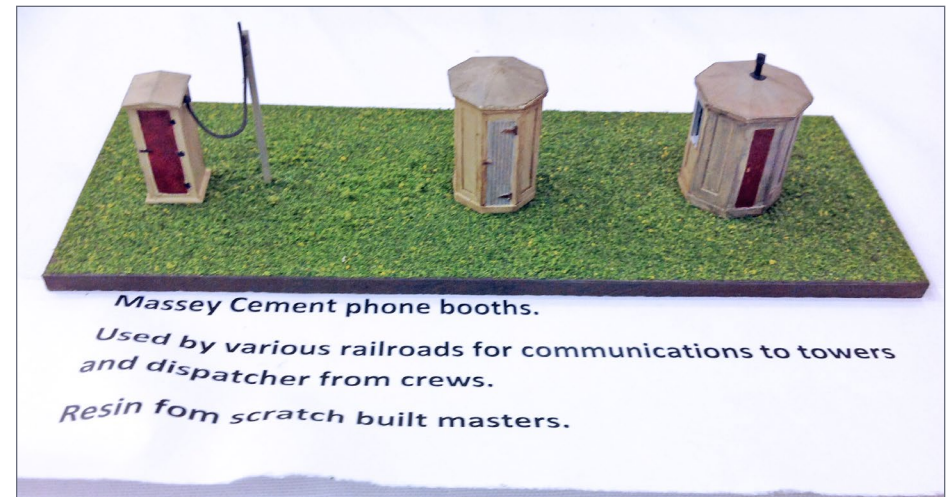

4. Will Jameson's Massey cement phone booths.

The Mid-Atlantic RPM featured clinicians known throughout the modeling community as well as up-and-coming local clinicians. Clinicians included:

- Ralph DeBlasi (Scratchbuilding in Styrene)
- Butch Eyler (Hands-on Weathering)
- Scott Mason (Converting Prototype Structure to Scale Model)
- Chuck Davis (Modeling Lehigh Valley Coal Cars)
- Jack Brown (Modeling Western Maryland Railway Circa '69-74)
- Tony Sissons (Modeling Chaos)
- Bernie Kempinski (The Model Railroad Goes to War)
- Mike Baker (Track Maintenance-Make the Railroad Work)
- Craig Bisgeier (Designing / Building Laser-Cut Boxcar Model)
- Marty McGuirk (Modeling Central Vermont in HO Scale)

## MID-ATLANTIC RPM MEET | 5

- Ramon Rhodes (Military Trains You've Never Heard Of)
- Bill Sartore (Lighting Structures, both clinic and hands-on)
- Lance Mindheim (Modeling a Miami Branch Line)
- Dave Ramos (New York Harbor RR: Modeling 1947)
- Brian Banna (Diesel Prototype Modeling: MP SD-40-2 #3320)

Butch Eyler and Bill Sartore carried their clinics into a corner of the display room and attendees got to try their hand at the techniques. Scotty Mason regaled the crowd with the lessons he learned in making a very large New England mill starting with drawings, including Monster Model Works laser-cutting this custom project.

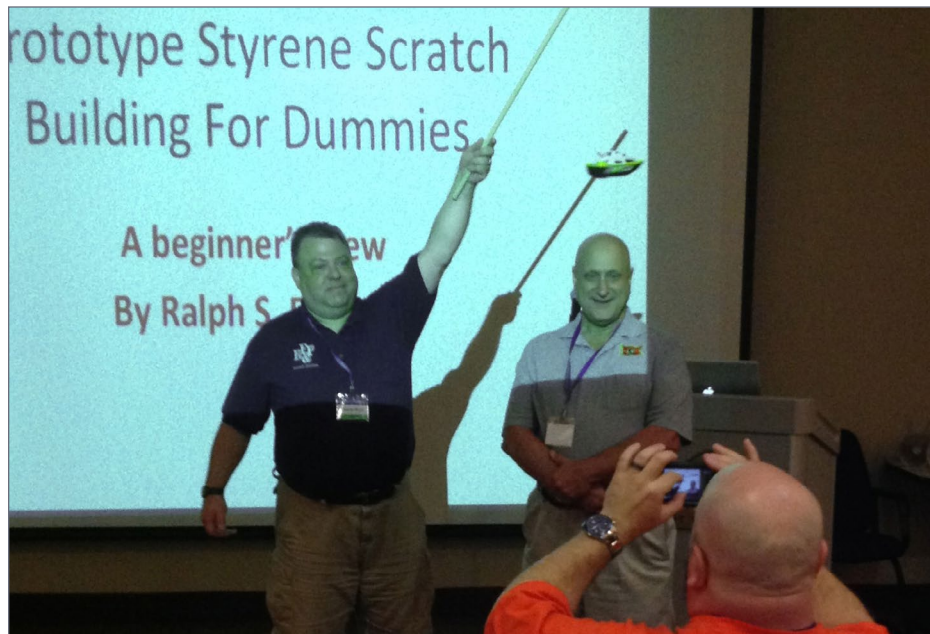

5. Norm Wolf, Ralph DeBlasi, and Craig Bisgeier paying homage to the 2013 MARPM which was held in a boat shed.

## MID-ATLANTIC RPM MEET | 6



6. Attendee doing weathering on a car bought at the MARPM. (Bought for \$5, sold for \$8 after weathering!)

Bernie Kempinski's machine gun style presentation of railroads and their impact on warfighting from before the US civil war to today held the audience spellbound even as he ran out of time (guess we need to read his new book!). Craig Bisgeier told the story of the trials and tribulations of designing and getting built a late 1880's box car, laser cutting is just part of this multi-media car.

Marty McGuirk told the story of his multiple fits and starts to design and build his dream home layout (something about the sound of a Sawzall isn't a good sign). Bill Sartore patiently and expertly explained how voltage and amperage (actually milliamps) needs to be taken into consideration when building lighting circuits. His hints during the hands-on part gave us confidence that we too could use those really tiny LEDs.



7. Craig Bisgeier autographing Motrak Model's Bisgeier Tool Company kit for a customer.



8. Bernie Kempinski's DODX 41000 Flat Car with M1 Tank – notice the tie-downs!

Dave Ramos's saga about building his New York Harbor Railroad had us all both laughing and groaning at what he went through. Ramon Rhodes wasn't a name I knew before the MARPM but he's one that I want to hear more from. He gave a jam-packed talk about various military trains that many of us had only oblique knowledge, but they were contemporary to all of us, and they were interesting!

At the beginning of the first clinic homage was paid to last year's venue (which was held in a boat shed with forklifts and boats regularly interrupting clinics). This year's venue was everything last years was not – it was first class (as was the rest of the meet).

Bernie Kempinski was among several attendees who brought in dioramas. His diorama of modern U.S. Army M1 tanks and M2 fighting vehicles being loaded to DoD flatcars also had them properly chained down.

There were 16 tables of vendors who attended the meet (many also were clinicians whose talks complemented their wares). Vendors included: Atlantic Coast Lines & Seaboard Air Line Railroads Historical Society, Inc., Bob the Train Guy, Bob's

## MID-ATLANTIC RPM MEET | 9

Photos, Caroline Craftsman Kits, Funaro and Camerlengo, Microlumina, Nick and Nora Designs, Paw of a Bear, Spring Mills Depot and Motrak Models (who arranged for a Craig Bisgeier autographed version of their Bisgeier Tool Company kit).

The night before the RPM an op session was held on Matt Thompson's smooth running Oregon Coast Railroad which was featured in Great Model Railroads 2014. It runs and operates as good as it looks.

The MARPM is well organized and nicely run. Many thanks to the organizers and staff (Norm Wolf, Bob Sprague, Shannon Crabtree, Butch Eyler, Michael Duggan, Daylene Wolf, and Ida Wolf) – they made it look easy.

Will I attend again? Yup, you betcha – I'm registered. And I hope you will consider the 2015 RPM this year. For more information see [marpm.org](http://marpm.org). Hope to see you there!



9. Bill Sartore showing how to wire micro-LEDs.

## MID-ATLANTIC RPM MEET | 10

### JOHN HUNTZINGER

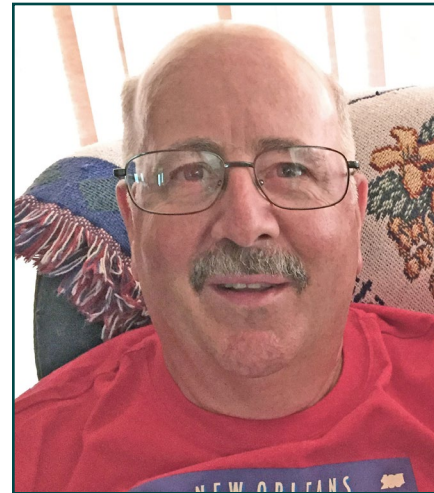

John is a retired US Air Force logistics officer and got his first train, a Lionel, for his first Christmas. John models the Santa Fe, Montana Rail Link, Bessemer & Lake Erie and most recently the Pennsylvania railroad.

John finds that being a member of a modular railroad club allows him to run his disparate railroad consists and longer trains. Margie, his wife of 40 years, has supported his train hobby through multiple military moves and the purchase of their retirement layout (and house). ■

 [Click here for reader comments](#)

SAVE 17.76%  
until July 6th  
Coupon code: HAPPY4TH

# What's **NEW** Model Railroad at the ... Hobbyist *Store*



	DVD	Download
- Sixteen layout tours set <b>HOT!</b> ...	<b>\$33.77</b>	<b>\$12.99</b>
- Backdrop painting how-to .....	<b>\$14.77</b>	<b>\$7.99</b>
- Extreme weathering how-to .....	<b>\$14.77</b>	<b>\$7.99</b>
- Streamliners at Spencer .....	<b>\$22.77</b>	<b>\$9.99</b>

DVDs and downloadable videos from ...

## TRAINMASTERS.TV

What our customers are saying ...

*"In comparrison to other videos that offer techniques, how to's, and demonstrations ... TMTV videos are top notch, keep it coming!"* -- Daniel S.



SAVE 17.76%  
until July 6th  
Coupon code:  
HAPPY4TH  
on checkout

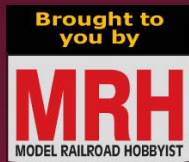

Visit [store.mrhmag.com](http://store.mrhmag.com)

The **NEW** Model Railroad Hobbyist STORE



Model Railroad Hobbyist | July 2015 | #65

# LOOK

column



Click here for  
reader comments

JEFF SHULTZ

## MRC DECODER DOCTOR ...

### MODEL RECTIFIER CORPORATION (MRC)

has long been a force in the DC power pack business, and also markets DCC systems in its Prodigy product line. One of the newest products is a dedicated decoder tester named the MRC Decoder DR. It will retail for \$99.98 when it is released.

The Decoder DR. resembles the current line of Prodigy throttles. It's an easily hand-held hammerhead shape about 7½ inches long by 3-1/8 inches wide at its widest point, with an LCD screen about 1 inch by 2 inches. Near the bottom front of the Decoder DR. is an eight-pin NMRA socket for testing decoders equipped with this plug prior to installing them in a locomotive. The base of the Decoder DR. has a permanently attached set of thin wires that can be connected to a section of track for decoder-equipped locomotives. The wires have a plug in the middle, allowing the test set to be easily disconnected from a fixed programming track. A much thicker set of wires plug into a socket on the bottom and are used to connect to an appropriately sized power

► **NEW PRODUCT FIRST LOOK**

## FIRST LOOK | 2

supply, which is not included. I used wire nuts to attach the loose ends of the wires to an MRC AD515 power supply I keep as a spare for my layout. The basic instruction set for the device is printed on its back, which is standard for Prodigy throttles.

As can be seen in [1], there are three groups of buttons on the Decoder DR. The top set are action buttons that define what you are going to do to the decoder, including reading and writing (programming) CVs, and switching from program track mode to

ops mode. Reading and programming addresses have their own set of buttons, and the Decoder DR. reads long, short and consist addresses – whichever is the active address type the decoder has configured as its primary address. The SYS button is a special function button which combines with a numbered function button to perform specific tasks. As an example, according to the instructions, SYS + 0 will reset a decoder to its factory defaults.

The second set of buttons consists of the number keys 0-9. These buttons act as function keys. For functions F0 to F9, the

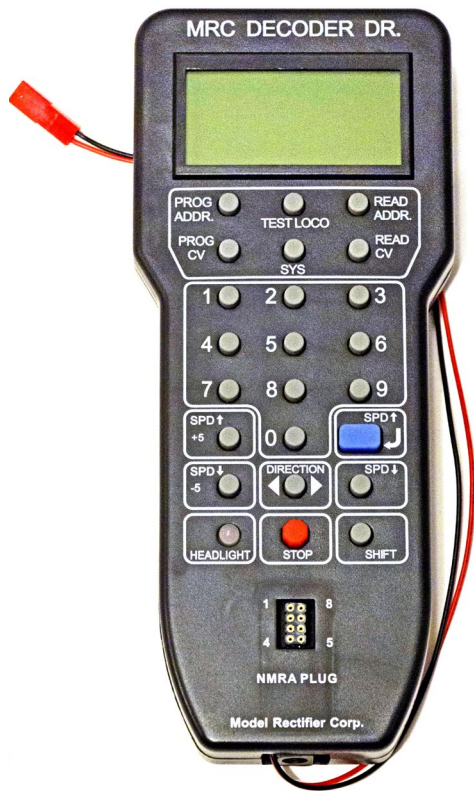

1. The front of the MRC Decoder DR., showing its Prodigy roots.

## FIRST LOOK | 3

user presses the 0-9 buttons, and for F10-F28, the user presses the SHIFT button and then the two digits. They are also used for entering addresses and CV values.

The remaining buttons are labeled SPD, and are what I consider the “throttle” buttons – two buttons increase or decrease speed in single increments (out of 100) and two others work in increments of five. The +1 Speed button also doubles as an Enter button and is colored blue. The last two buttons are the DIRECTION button and the STOP button, which is solid red. The STOP button only stops motion. It does not affect other functions such as sound or lighting.

Decoder operations are straightforward. To program an address, press the PROG ADDR button, enter the address with the number keys, and press the blue Enter button. To program a CV you press the PROG CV button, enter the CV number with the number keys, and press the Enter button. You then use the number keys to enter the CV value and press Enter again to finish. Similarly, READ ADDR reads the primary address on the decoder. With READ



2. The instructions printed on the back of the MRC Decoder DR.

## FIRST LOOK | 4

CV, pressing the CV number and Enter will display the value contained in that CV. The instructions note that the Decoder DR. might not be able to read the address from a decoder, and this was borne out by my testing. The majority of my locomotives are equipped with TCS decoders, and it was hit-or-miss whether or not the Decoder DR. could read the address. On the other hand, a Loksound 3.5-equipped locomotive that my command station and Decoder Pro balked at was read easily by the Decoder DR.

To test a decoder, press the TEST LOCO button and enter the decoder address, even if you have read the decoder address previously, then hit Enter. You can then use the SPD (speed) buttons to adjust the locomotive's speed, and the DIRECTION button to change directions, as well as the STOP button to stop motion. I noticed that several times I had to hit a function key, usually 0, before the locomotive would start moving, an odd quirk I quickly adjusted to. At this point all



3. Bottom view of the MRC Decoder DR., showing the programming track wires and the socket for the wires from the transformer.

the functions supported by the decoder could also be tested using the number keys. In Test Loco mode the Decoder DR. functions as a low-power, single-locomotive command station. For uninstalled decoders with an NMRA plug, instead of using the SPD keys, press SYS + 1 to test the motor functions. This then returns either "good" (passes) or "bad" (fails) on the LCD as a result.

## FIRST LOOK | 5

Additionally, an LED lamp on the Decoder DR. glows green to represent the forward headlight, and red for the rear headlight.

The Decoder DR. is intended to be a basic decoder and decoder-equipped locomotive tester for a modeler with a workbench in a separate location from the layout. For more complex decoder programming, especially on sound decoders, a more advanced system using a computer running JMRI Decoder Pro would be more appropriate. For a modeler with a small, single operator layout, the Decoder DR. functions as a combined command station, booster and throttle at a reasonable price.

**Link:**

[modelrec.com/search/product-view.asp?ID=8273](http://modelrec.com/search/product-view.asp?ID=8273).



**Click here for  
reader comments**

## Did you see this MRH video?



**MicroEngineering  
Track laying tips  
from Charlie  
Comstock**

**Watch the video now**





# You're the kid.



## Welcome to the candy store.

- 180,000 square feet of sheer bliss
- Over 250 manufacturer & retailer booths
- 50,000 square feet of modular layouts
- "Ask the Collectibles" appraiser
- Trains, accessories, collectibles & more
- Hands-on demonstrations

**August 28 - 30, 2015**  
**Portland Expo Center**

2060 North Marine Dr.  
 Portland, OR 97217

Sponsored by



**CLICK HERE  
 FOR ALL THE  
 DETAILS!**

[www.nationaltrainshow.com](http://www.nationaltrainshow.com)

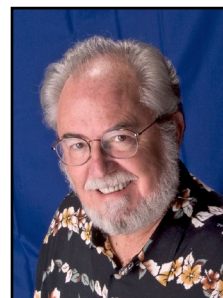
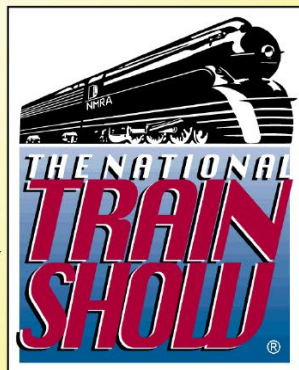

Model Railroad Hobbyist | July 2015 | #65

# JULY NEWS

column

RICHARD BALE *and* JEFF SHULTZ



**Click here for  
 reader comments**

## Quality Craft-Scalecoat owner announces retirement

**Quality Craft Models** of Northumberland, PA will cease operations effective June 30, 2015. The announcement was made by Joe Hayter, who began working for founder Bob Weaver in 1970 and acquired the business in 1994. In addition to the Quality Craft brand, the shutdown includes Weaver Models and Scalecoat Paint. Weaver established Quality Craft in 1965 with the introduction of wood kits for rolling stock and model buildings.

Over the years the company's focus has centered on two- and three-rail O gauge models. The Weaver Models brand was launched in the early 1980s with the introduction of an O gauge plastic injection-molded twin-bay hopper car. In 1990 Weaver began selling O gauge brass locomotives built by Samhongsang. That relationship ended in the mid-1990s when the Korean

▶ THE LATEST MODEL RAILROAD PRODUCTS, NEWS & EVENTS

maker agreed to a North American exclusivity contract for O gauge models with Mike's Train House (MTH). In 1997 Weaver returned to the brass market with models produced by alternate Korean sources.

Quality Craft's line of model paint, marketed under the Scalecoat brand, is highly regarded by both hobbyists and professional builders. Hayter said the business remains viable, however he feels it is time to retire. The company employs about half a dozen full- and part-time workers. Several expressed both surprise and sadness at the announcement ...

### New minimum advertised price policy for Athearn

**Horizon Hobby** has advised its dealer network that it intends to apply a Minimum Advertised Price (MAP) on selected Athearn products. The MAP policy will apply to certain N and HO scale Ready-To-Roll items and all Athearn Genesis products. The MAP on individual products will be established at 85 percent of the manufacturer's suggested retail price and will remain in effect from the time of the announcement through 90 days after the initial shipping date of the product to retailers and consumers. Horizon said it will post MAPs on its announcements page and in the dealer product listings on FastServe ...



### Birthday celebration at Bowser

Happy 95th birthday to Mrs. English, co-founder and past president of **Bowser Manufacturing**. We received this photo from her son, Lee English, who has been in charge of the

family business for the past several years. Lee said his mother still comes into the office every day. She rides her tricycle for the short commute ...

### NEW PRODUCTS FOR ALL SCALES

**Cascade Rail Supply** sells a wide selection of pre-cut Homasote roadbed for N, HO, HO<sub>N3</sub>, S, O, and On30 trackwork. The CRS products include mainline (18 inches thick), and branchline (12 inches thick) roadbed and turnout pads. All items are offered with shoulders beveled either 30 or 45 degree. CRS also offers custom work for special applications. For complete information visit [cascaderailsupply.com](http://cascaderailsupply.com).

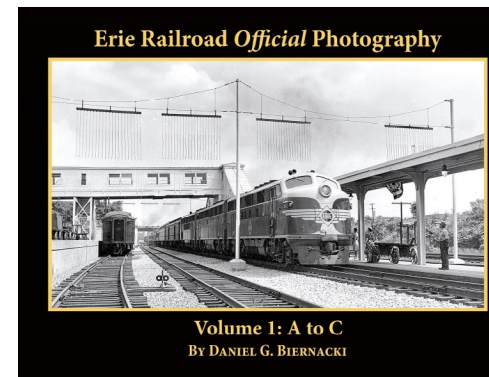

**Morning Sun** has released Volume One of *Erie Railroad Official Photography*. This new book is composed of images by Erie's company photographers in the 1940s, 1950s and early years of the Erie-Lackawanna merger. The collection offers management's official perspective

on featured trains, new and revitalized facilities, special events, and operations – all in stunning black and white photography.

Additional new hardbound books from Morning Sun include *Florida East Coast Railway* by Bill McBride. The all-color book covers the steam-to-diesel transition era and the fast trains that raced through the wet, palm-treed landscape of Florida.

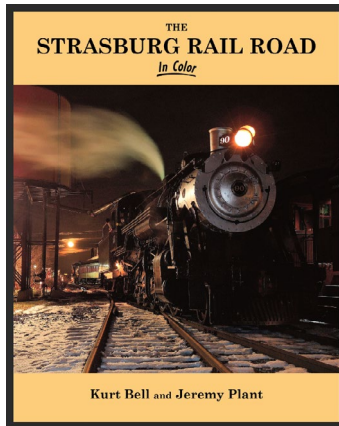
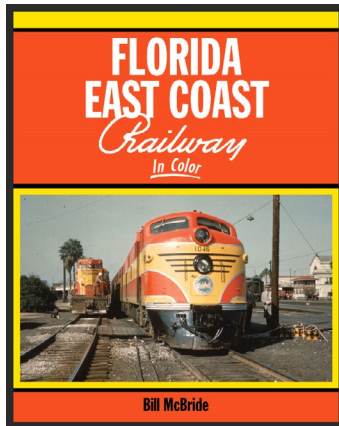

By contrast, *The Strasburg Rail Road*, co-authored by Kurt Bell and Jeremy Plant, presents a relaxed view of the Lancaster County steam-powered line

that transports railfans and tourists through the heart of the fabled Pennsylvania Dutch farm country.

Also new is *Chicago, Burlington & Quincy Facilities in Color, Volume 2*, which highlights the Burlington's Hannibal Division via a thorough examination of noteworthy facilities and trains. For more information, go to [morningsunbooks.com](http://morningsunbooks.com).

## O SCALE PRODUCT NEWS



**Atlas O** plans to release new cylindrical covered hopper cars during the fourth quarter of this year. Six-bay versions of the car will be available

for Detroit & Toledo Shore Line, Texas Pacific Lines, Southern Pacific, and Wabash. Triple-bay cars will be available for Conrail and Seaboard System.



A Trainman series Alco RSD-7/15 diesel locomotive is scheduled for release by Atlas O during the first quarter of 2016. Features include directional LED lighting, etched metal grilles, and separately applied wire grab irons. High-nose versions of the locomotive will be available for Chesapeake & Ohio; Pennsylvania Railroad; Canadian Pacific; and Duluth, Missabe & Iron Range. Two Santa Fe schemes will be available: black with zebra stripes on a high nose, and blue and yellow applied to a low nose version of the locomotive. The model will be available with a variety of two-rail and three-rail control and sound systems.



Atlas O has scheduled the release of a new run of PS-2 triple-bay covered hopper cars for the fourth quarter of 2015. Road names for the Trainman series model will be SSW-Cotton Belt, Baltimore & Ohio, Great Northern, Illinois Central, Louisville & Nashville, and Santa Fe. For additional information on these and other Atlas O products, contact your dealer or visit [atlaso.com](http://atlaso.com).

## HO SCALE PRODUCT NEWS

**Accurail** has released kits for four new HO scale models. They include a Grand Trunk Western 50-foot steel boxcar with

## JULY NEWS | 6



modified and running board removed during a 1973 rebuild.

Superior doors and Improved Dreadnaught ends. The model is based on a prototype built in 1953 that had its original ladders

Also new from Accurail is a Central of Georgia 40-foot PS-1 steel boxcar. It follows a prototype built in 1957 with Youngstown doors and P-S wash-board ends.

One of the lesser-known shortline coal carriers in western Pennsylvania was the Montour Railroad Company. Accurail is offering a kit for an HO

scale version of a Montour 50-foot offset-side twin-bay hopper car. The model is patterned after a prototype built in 1946 and rebuilt in 1963.

Completing Accurail's July list of new kits is a 40-foot Chicago, St. Paul, Minneapolis & Omaha double-sheathed wood boxcar. The model displays a *Route Of The 400* slogan and a Chicago & North Western herald. The HO scale model follows a prototype built in

## JULY NEWS | 7



1919 that retained its vertical brake shaft, horizontal brake wheel, and wood running board in a 1941 rebuild. All Accurail kits include appropriate trucks and Accumate automatic couplers. For additional information contact your dealer or visit [accurail.com](http://accurail.com).



Atlas Model Railroad Company will release a kit for an HO scale 1937 AAR 40-foot boxcar during the fourth quarter of this year. With its Dreadnaught ends and a straight panel roof the prototype represented a major step in boxcar standardization. The Trainman series kit will be available in three numbers each for Nickel Plate Road, Canadian National, Minneapolis & St. Louis, Clinchfield, Erie, and New Haven. Trucks and couplers are included in the kit which will be released with an MSRP of \$20.95. An undecorated version will list at \$15.95.



Ready-to-run models coming late this year include a Thrall articulated auto carrier with working diaphragms to facilitate drive-through loading. Road names will be Norfolk Southern,

Denver & Rio Grande Western, Florida East Coast, Union Pacific, Northwestern Oklahoma Railroad, TTX (speedwriting), and TTX (2008 logo).

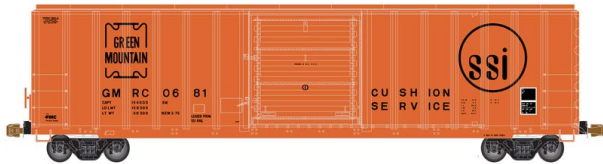

Another release of the Atlas FMC 5077 cu.ft. boxcar is scheduled for the fourth quarter of

this year. Identifying features of the Plate B car include a flat X-panel roof, seven panels on either side of the single door, and non-terminating box-corrugated ends. Features of the HO scale Master Line model include separate wire grab irons and etched-metal end platforms. Three numbers each will be available for Green Mountain, Burlington Northern, Clarendon & Pittsford, Sierra Railroad, Railbox, and Vermont Northern. Cars decorated for CSX (*Ease Up* slogan) and CSX (safety stripes) will be available in two road numbers each. For additional information on these and other Atlas products, contact your dealer or visit [atlasrr.com](http://atlasrr.com).



**Bachmann Trains** has expanded its line-up of EMD GP7 diesel locomotives with two new road

names: SSW Cotton Belt in the distinctive Black Widow paint scheme developed by the road's SP parent, and Boston & Maine in maroon and yellow with a Minute Man logo.



Additional road names include Rio Grande, Pennsylvania, New York Central, and Western Pacific.

The ready-to-run HO scale model comes with a dual-mode NMRA-compliant DCC decoder for speed, direction, and lighting. For additional information contact your dealer or visit [bachmanntrains.com](http://bachmanntrains.com).



**Classic Metal Works** plans to release a series of HO scale Mini Metal brand railroad MOW vehicles in August. Road names will

include (clockwise from the lower left) Milwaukee Road, Union Pacific, Pennsylvania-Excelsior Leasing, New York Central, Santa Fe, and a unique 1955 Ford sedan modified for hi-rail inspection service. The models are the direct result of an industry-wide request officials of Classic Metal Works made early last year, in which they asked for help in developing MOW vehicles for the 1960s. The response was even greater than hoped for with many individuals and North American railroad historical societies providing photos, diagrams, and color specifications for the project. More road names are expected to be released in the future. For

additional information contact your dealer or visit [classicalmetal-works.com](http://classicalmetal-works.com).



**Imperial Hobby Productions** (IHP) is preparing a second run of HO scale Kawasaki Light Rail Vehicles

non-powered display models for release late this year. The assembled injection molded styrene HO scale models will be available in four new SEPTA-licensed paint schemes and car numbers at an MSRP of \$75.00 each. Unassembled kits are also available at a list price of \$39.95 each. For more information visit [ihphobby.tripod.com/hokawasakilrv/holrvplastickit.html](http://ihphobby.tripod.com/hokawasakilrv/holrvplastickit.html).



New ready-to-run HO scale freight cars coming from **Kadee Quality Products** in September include a Central of New Jersey 40-foot PS-1 boxcar. The prototype was built in 1957 and repainted in April 1967 in

boxcar red. When the PS-built cars received the six-panel 8-foot Superior doors is unknown.



Also due in September is a Chicago & North Western 50-foot PS-1 boxcar with 8-foot Youngstown corrugated steel

doors. Kadee's HO version will be painted in the same red oxide as the prototype when it was built in 1955. Both models will be equipped with Kadee #2100 knuckle couplers. Contact Kadee at [kadee.com](http://kadee.com), or your dealer for reservation information.



**Kato USA** has added Reading and Western Pacific to its list of custom decorated GP35 locomotives. The HO scale EMD GP35 diesels are hand decorated by Kobo

Custom Paint of Japan. Two numbers are available for each road. Delivery is planned for September. The models are available only from Kato direct.



The models represent Phase 1a versions of the prototype with dynamic brakes. Features include directional headlights, all-wheel electrical pickup,

blackened metal wheels, and installed handrails. The DC models come with an 8-pin plug for installation of an aftermarket DCC decoder. The direct link to Kato's online store is [katousa.com/Zcart/index.php?main\\_page=index&cPath=166](http://katousa.com/Zcart/index.php?main_page=index&cPath=166).



**Monroe Models** is selling a two-pack of HO scale kits that assemble into double billboards. That is a total of four billboards at an MSRP of \$17.95. The models are based on standard billboards common in North America from about 1910 through the 1960s.



The components in the kit are made from laser-cut plywood, basswood, and fiberboard with peel and stick trim. Also included is a selection of vintage advertising signs. The advertising image dimensions are 2.625

x 1.35 inches. The assembled billboard structure measures 5.5 by 1.25 by 2.0 inches high. To order visit [monroemodels.us](http://monroemodels.us).



**Monster Model Works** plans to begin shipping a kit for this HO scale flat background industrial structure by the 15th of this month. Called Hansen

Machine & Tool, the kit assembles into a realistic building constructed of concrete blocks topped by an aging brick crown. Two loading bays are provided with iron bars protecting the other doors and windows. Jimmy Simmons, the man in charge

of the show at MMW, said the design is based on a prototype he spotted in Los Angeles. Components include 3D engraved concrete block and brick walls, 3D engraved corner pieces and engraved terra cotta coping. The wall bumpers, doors, security doors and bars are all laser-cut basswood. Drains and signage are also included. The finished structure has a footprint of 11.5 x 1.62 by 3.06 inches high. The kit can be ordered now at a reduced introductory price. For details including ordering instructions visit [monstermodelworks.com](http://monstermodelworks.com).



Last Chance Garage is a new cast resin structure kit just released by **Rusty Rail**. The structure measures 3.5 x 2.875 x 2 inches tall. Components in the kit include the cast resin roof, building, and gas pump island, wood for roof supports and the sign post, and paper sign material. The island with the gravity-fed gas pumps can be positioned anywhere. The details shown on the side of the building are cast in place. Vehicles in the illustration are not included. To order go to [rustyrail.com/HOShacksCastingsPage.htm](http://rustyrail.com/HOShacksCastingsPage.htm).

**Tangent Scale Models** has released a second run of its prototypically accurate Pullman-Standard PS-2CD 4750 cu.ft. covered hopper car. The HO scale ready-to-run model is available now



in eight new road names plus primed but unlettered. Tangent's beautifully detailed model

follows the same variations in road name details as Pullman-Standard applied to the prototype. They include five different brake systems, three different outlet gates, two different sets of roof hatches, four jacking pad sets, with or without shaker brackets, two roof overhangs, three different running board and crossover platform options, end ladder options, five brake wheel housing and clevis options, and two brake wheel options. This highly accurate model comes with Kadee couplers and Tangent 100-ton roller bearing trucks with metal wheelsets.

Multiple road numbers are available for Denver & Rio Grande Western original 12-74 orange with large logo; ICG original 1979 simplified scheme, Chicago & North Western original 1974 dark green with two shades of yellow lettering, and Chicago & North Western with retrofitted smooth hatches in 1974 blue oxidized to 1990s appearance.



Also, SCL Family Lines original 1980 beige scheme, with Georgia-Clinchfield-West Point Route

logo and matching beige trucks; CSXT ex-SCL Family Lines cars in post-1980s restenciled scheme; FLIX - COOP - Far-Mar-Co with both Farmland Industries COOP and Far-Mar-Co placards; and PTLX post-1975 white lease private lessor plain scheme with black underframe and ends. An undecorated

ready-to-run model in unlettered gray primer with 1974-75 truck brakes is also available. For additional information visit [tangentscalemodels.com](http://tangentscalemodels.com). Note that Tangent allows mixing for multiple car discounts on quantity purchases in increments of 6, 12, 36 and 48.



**Walthers** has announced the availability of a newly-tooled 50-foot ACF exterior-post boxcar. The Mainline series HO scale model is available in two numbers each for Kansas City Southern, Santa Fe, CSX, Missouri Pacific, Pickens Railroad, and Railbox.



Walthers has also released a Northeast-style steel cabooses with a centered cupola. A notable feature of the HO scale Mainline series model are flush-mounted windows. Road names are New Haven, Chesapeake & Ohio, Chessie - Western Maryland, Chicago & North Western, and Conrail.



Walthers plans to release this Proto series 40-foot UTLX 16,000 gallon Funnel-Flow tank car next month. The HO scale model will have etched metal walkways and platform. Road names will be AMMX-KT Clays, AMMX-Cyprus, PROX-Procor, J.M. Huber, KLRX, and GATX-Staley. The position of the dome



and platform will be in accordance with prototype practice of each road name.



Another release of Walthers Proto series 50-foot CC&F bulkhead flat cars has been scheduled for September. Road

names will be Canadian National, Algoma Central, BC Rail, and Ontario Northland.

Pennsylvania Railroad 80-foot class P70 steel coaches in several different decorating schemes are scheduled for release next February. The HO scale models will be produced from new tooling and will represent cars rebuilt with air conditioning. Features include LED interior lighting, stainless steel grab irons, and PRR 2D-PF roller bearing trucks with 36-inch metal wheelsets. PRR cars will be available in the original 1939 scheme with Futura lettering, the 1941 scheme with block lettering, 1947 scheme with block lettering and three stripes beneath the windows, and the 1952 scheme with block lettering and a black roof. Additional road names will be Pennsylvania-Reading Seashore Lines with three stripes and Long Island Railroad. Each model will have matching car number decals. For complete details contact your dealer or visit [walthers.com](http://walthers.com).

## N SCALE PRODUCT NEWS

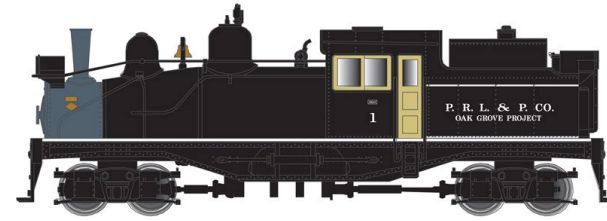

**Atlas Model Railroad Company** will release its N scale two-truck Shay early next year in several

new paint schemes. Although the external connecting rods and drive shaft of the diminutive locomotive are in motion, the model is actually driven by a reliable worm drive and truck-mounted gear tower. In addition to the Portland Railway Light & Power version shown here, road names will be Arcata & Mad River, Western Forest Industries, Yawkey Bissell Lumber Co., Panhandle Lumber Co., and Manary Logging Co. An undecorated model will also be available as well as a painted but unlettered Shay.

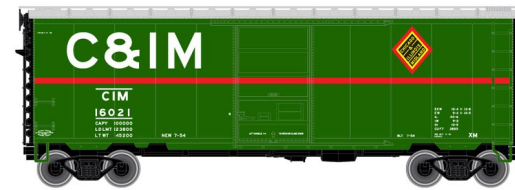

Scheduled for arrival from Atlas late this year is a group of N scale 40-foot PS-1 boxcars featuring etched metal running

boards and Barber S-2A 50-ton trucks with metal wheelsets. Cars with 6-foot Superior doors will be available decorated for Chicago & Illinois Midland; Copper Range; Chicago Great Western; Duluth, South Shore & Atlantic; and Green Bay Western. Models decorated for CP Rail and New York Central will be equipped with Youngstown doors.

Also due from Atlas late this year are Thrall articulated auto carriers with working diaphragms to facilitate drive-through loading. Road names will be Denver & Rio Grande Western, Norfolk Southern, Florida East Coast, Union Pacific,



Northwestern Oklahoma Railroad, TTX (speedwriting), and TTX (2008 logo). Contact your dealer for additional information or visit [atlasrr.com](http://atlasrr.com).



**BLMA** is preparing another production run of its highly-rated General Steel

Casting 60' flat car. The GSC prototype was used on a number of railroads beginning in the mid-1950s with many continuing in MOW service today. The N scale model rides on BLMA's 70-ton ASF Ride-Control trucks fitted with 33-inch metal wheelsets. New road names due early next year will be Missouri Pacific MOW, MP MOW with stripes (above), Missouri Pacific (buzz saw logo), Union Pacific (1966 scheme), Great Northern, and Illinois Central Gulf.



Road names still available from the initial production

run include ATSF (above), Burlington Northern, SSW-Cotton Belt, Illinois Central, Pennsylvania, and Wabash. For additional information contact your dealer or visit [BLMamodels.com](http://BLMamodels.com).

**Fox Valley Models** has announced a new series of CSX Heritage paint schemes for its N scale ES44AC diesel locomotive. The initial group, scheduled for release late this year, will include PRR (green), Pittsburgh & Lake Erie, Seaboard System,

and Seaboard Coast Line. The release of the second group of Heritage locomotives is scheduled for early 2016. Decorating schemes will be Nashville, Chattanooga, & St. Louis; Georgia Railroad; Conrail; and Western Maryland. FVM plans to release additional groups of Heritage locomotives later next year. InterMountain Railway is responsible for marketing Fox Valley Models products. For additional information contact your dealer or visit [intermountain-railway.com](http://intermountain-railway.com).



**Micro-Trains Line** has released several new N scale ready-to-run cars including this big Baltimore & Ohio boxcar.

The prototype of the sixty-footer was built in 1963 with double plug-doors. The model rides on 100-ton roller bearing trucks.



This 50' Santa Fe rib-side boxcar has double Youngstown sliding doors, non-terminating box corrugated ends and

a Shock-Control underframe. The decorating scheme includes modern-day graffiti.



The prototype of this Canadian National 33' twin-bay hopper car was built in 1936 with flat sides. It was later rebuilt

with panel sides to increase the cars' load capacity.



Micro-Train's yellow Baby Ruth car represents a wood sheathed NADX refrigerator car built in 1928 with ice bunkers.



M-T's classic Southern Pacific heavyweight 70-foot baggage car comes with six-wheel Commonwealth trucks. The N scale ready-to-run model is also available decorated for Great Northern. For additional information on all Micro-Trains Line models contact your dealer or visit [micro-trains.com](http://micro-trains.com).



**Monroe Models** is selling a two-pack of N scale kits for Double Billboards for a total of four billboards at an MSRP of \$14.95. The models are based on standard billboards common in North America from about 1910 through the

1960s. The components in the kit are made from laser-cut plywood, basswood, and fiber board with peel and stick trim. Also included is a selection of vintage advertising signs. The dimensions of the advertising image are 1.42 x .73 inches. The assembled billboard structure measures 3 by .625 by 1.25 inches. To order visit [monroemodels.us](http://monroemodels.us).

## Z SCALE PRODUCT NEWS



**Micro-Trains Line** shared this photo of a preproduction sample of their new Z scale boxcar currently under devel-

opment. The modern 50-foot outside-braced dual-door boxcar, with an interesting combination of plug and sliding doors, is scheduled to be available decorated for a wide selection of contemporary railroads including ABOX, CN, BCRail, Mopac, UP, and MDW. If all goes according to plan, they will be released before the end of this summer. For additional information, contact your dealer or visit [micro-trains.com](http://micro-trains.com).

## NEW DECALS, SIGNS AND FINISHING PRODUCTS

**Black Swamp Shops** sells HO scale decals for the Akron, Canton & Youngstown Railroad formerly available from the ACY Historical Society. Items currently available include lettering sets for ACY series 7000-7199 USRA twin-bay open hopper cars. Also ACY series 500-539 1958 cu. ft. covered hopper cars. A variety of decals are available for ACY Alco and GE diesels, steam locomotives, and steel cabooses. For more information visit [greatdecals.com/Black\\_Swamp\\_Shops.html](http://greatdecals.com/Black_Swamp_Shops.html).

The newest HO scale silk screened decal lettering sets from **Daniel Kohlberg** are for ATSF BX-94/97/114 50' boxcar 1965+ (original scheme and 1970s all red repaint scheme), and

ATSF BX-94/97/114 50-foot boxcar 1981+ (Helvetica all red repaint scheme). Photos, prototype information and ordering instructions are available at [home.mindspring.com/~paducah](http://home.mindspring.com/~paducah).

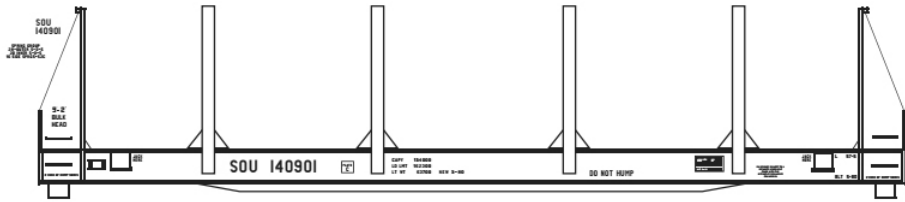

**Mask Island Decals** has Mask Island Decals has a lettering set for a Southern Railway converted pole car (item 87-296). To order go to [maskislanddecals.com](http://maskislanddecals.com) and select freight.

**87-1505** FRUIT GROWERS EXPRESS (FGEX)  
EARLY VENTILATED AND INSULATED 40' AND 50' BOXCARS

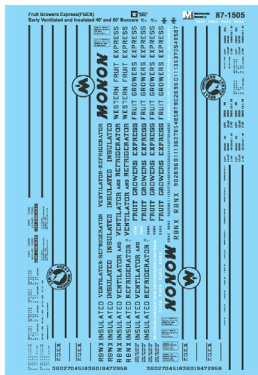

**87-1506** GULF MOBILE & OHIO (GM&O)  
40' AND 50' BOXCARS



The latest water slide decals from **Microscale Industries** include a lettering set for Fruit Growers Express (FGEX) the provides material for a variety of FGE, Great Northern, and Monon ice-bunker

reefers and insulated boxcars. Also new is a decal set for Gulf, Mobile & Ohio that will letter 40-foot and 50-foot GM&O boxcars. Popular decals now back in stock include diesel lettering sets for NS, SP, and PRR; Wheeling & Lake Erie and Milwaukee

Road boxcars; and Denver & Rio Grande narrow gauge freight equipment. For more information contact your dealer or visit [microscale.com](http://microscale.com).

## **i** SEND US YOUR PRODUCT ANNOUNCEMENTS

If you are a hobby manufacturer with a product announcement, just [click here](#) and submit your announcement to us. Our web site and free magazine reach continues to grow, so get on board this new media train! ■

### DISCLAIMER .....

The opinions expressed in this column are those of the writer and do not necessarily reflect the opinion of *Model Railroad Hobbyist* or its sponsors. Every effort is made to provide our readers with accurate and responsible news and information, however, neither *Model Railroad Hobbyist* or the writer of this column can be held responsible for any inaccuracies or typographical errors that may inadvertently appear in this column.

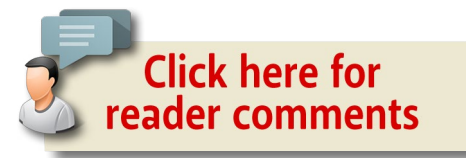

 BRIEFLY NOTED AT PRESS TIME ...

**Athearn's** ([athearn.com](http://athearn.com)) May-June 2016 delivery schedule includes a group of HO scale Genesis SD70 locomotives. Units with standard cabs will be available decorated for IC and Conrail. The production run includes SD70M diesels decorated for NYSM (Susquehanna) and SP, a Union Pacific version with flared radiators, and an ATSF SD75M.

The list of new Ready-to-Roll models includes SD45T-2 locomotives decorated for BLE, DM&IR, G&W, UP, SP, and SP with speed lettering. HO scale rolling stock coming in May-June includes new road names and decorating schemes for 85-foot TOFC flat cars, 50-foot FGE-built boxcars with Youngstown doors, 53-foot Wabash Duraplate trailers, and 36-foot wood reefers. RTC 20,900 gallon tank cars will be available in both HO and N scales.

We'll have full details in the next edition of *Model Railroad Hobbyist* ...

**Fox Valley** is accepting reservations through July 15 for an early 2016 release of an N scale GEVO locomotive. Road names will be Iowa Interstate (two schemes) and CSX including the "How Tomorrow Moves" slogan.

A brief video of the prototypes in action is available at [youtube.com/watch?v=sb8mk2HSJUC](https://www.youtube.com/watch?v=sb8mk2HSJUC) ...

**Funaro & Camerlengo** has released new resin kits for Baltimore & Ohio class N12G and BWCX – Berwind class BW-1 twin-bay open hopper cars. The HO scale kits include body and detail castings, grab irons, wire for air lines, appropriate decals, and Tichy cast styrene brake components. The B&O kit is available with either AB or K-type brakes. F&C cast resin craftsman kits are sold without trucks or couplers. For additional information including a list of dealers visit [fandckits.com](http://fandckits.com) ...

**InterMountain Railway's** ([intermountain-railway.com](http://intermountain-railway.com)) production schedule includes an early 2016 release of General Electric ES44AC HO scale diesels. Road names will be GE demonstrator, ArcelorMittal, Iowa Interstate, Ferrosur, UP (two versions), BNSF, and Ferromex Diex Anos. Also due for release in January-February are HO and N scale versions of cylindrical covered-hopper cars with trough hatches ...

Shawn Cavaretta, owner of **Minuteman Scale Models** ([minutemanscalemodels.com](http://minutemanscalemodels.com)) has acquired Scalecoat Model Paints from **Weaver Models**. The sale

includes mixing equipment, color formulas, bottling and packaging equipment, and existing inventory. Cavaretta said availability of the full assortment of Scalecoat paint should be near normal within 30 to 45 days. As noted previously, Jack Hayter, owner of Weaver Models, has announced plans to retire effective July 17, 2015. In an interview with MRH, Hayter confirmed the sale of Scalecoat to Cavaretta and expressed confidence that the quality of the well-regarded line will be maintained by the new owner. Although Hayter declined to name the participants, he acknowledged that negotiations are underway for the sale of Weaver O gauge products ...

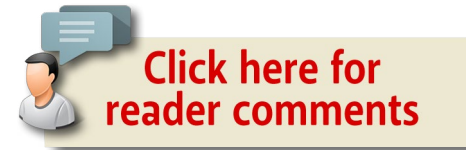

 THIS MONTH'S BONUS EXTRAS

MRH SUBSCRIBERS GET ACCESS TO FREE BONUS extras, but you do have to be a subscriber! That's easy because [subscribing is free \(just click this link\)](#).

The bonus extras this month include:

- High quality versions of the issue videos
- Extra photos from the Lewis County club layout
- Device wallpaper of the best photos this issue

To access the bonus extras, click the link below:

[BONUS DOWNLOADS FOR THIS ISSUE](#)



# SELECTED EVENTS

## July 2015

*(Please note that many events charge a fee. Check individual info website for details.)*

**CALIFORNIA, McCLELLAN, (Metro Sacramento),** July 15-19, National Summer Live Steamup, Lions Gate Hotel, 3410 Westover Street. Info at [summersteamup.com](http://summersteamup.com).

**CALIFORNIA, POMONA,** July 18-19, The Great Train Show, at Fairplex, 1101 West McKinley Avenue. One of Southern California's largest train shows. Info at [greattrainexpo.com](http://greattrainexpo.com).

**COLORADO, DENVER,** July 5-11, National Garden Railway Convention, Crowne Plaza Denver International Airport Hotel, 15500 East 40th Street. Info at [ngrc2015.com](http://ngrc2015.com).

**TEXAS, BEAUMONT,** July 22-25, NMRA Lone Star Region Convention, Holiday Inn Plaza, 3950 I-10 South Walden Road. Info at [lsr2015.com](http://lsr2015.com).

## August 2015

**ARIZONA, PRESCOTT VALLEY,** August 15, Beat The Heat Swap Meet, at Liberty Traditional School, 3300 N. Lake Valley Road. Sponsored by Central Arizona Model Railroad Club. Info at [trainweb.org/camrrc/SwapMeet/SwapMeet.html](http://trainweb.org/camrrc/SwapMeet/SwapMeet.html).

**CALIFORNIA, FREMONT,** August 1, Third Annual Model Railroad Swap Meet, at Niles Depot, 37592 Niles Blvd, 94536. Co-sponsored by the Niles Depot Historical Foundation and Tri-City Society of Model Engineers. Vendor info available from Mike (650) 207-4397 or Bob (510) 325-2092.

**CALIFORNIA, TEHACHAPI,** August 8-9, Train Show, sponsored by Tehachapi Loop Railroad Club, 410 West D Street. Info at [tlrc.club/events](http://tlrc.club/events).

**FLORIDA, THE VILLAGES.** August 22-23, Summer Train Show & Sale, Savannah Regional Recreation Center, 1545 Buena Vista Blvd. Info at [villagerailclubs.blogspot.com](http://villagerailclubs.blogspot.com).

**ILLINOIS, BIG ROCK,** September 6, Illinois Live Steam & Milwaukee Live Engineers Meet, at Plowman's Park, 48W508 Hinckley Road. Info at [facebook.com/PrairieStateRailroadClub](https://facebook.com/PrairieStateRailroadClub).

**ILLINOIS, COLLINSVILLE (Metro St Louis),** August 7-8, St. Louis Railroad Prototype Modelers Meet, featuring 16,000 sq. ft. of display area, at Gateway Convention Center, One Gateway Drive. Co-sponsored by RPM committee and the Gateway Division, Mid-Continent Region, NMRA. Info at [home.mind-spring.com/~icg/rpm/stlrpm.pdf](http://home.mind-spring.com/~icg/rpm/stlrpm.pdf).

**NORTH CAROLINA, DENVER,** August 28-30: HO modular layout display by The Sipping and Switching Society of North Carolina. Salem United Methodist Church, 378 N. Pilot Knob Rd, Denver NC 28037. Info: [groups.yahoo.com/neo/groups/SandSSofNC/info](http://groups.yahoo.com/neo/groups/SandSSofNC/info).

**OHIO, CINCINNATI,** August 8, Summerail at C.U.T., featuring a day of high quality railroad photography, at Cincinnati Union Terminal, 1301 Western Avenue. Info at [cincinnatiirclub.org/Summerail/index.shtml](http://cincinnatiirclub.org/Summerail/index.shtml).

**OREGON, PORTLAND,** August 23-30, NMRA National Convention, at Double Tree by Hilton Hotel Portland. Info at [nmra2015.org](http://nmra2015.org).

**OREGON, PORTLAND,** August 28-30, National Train Show, at Portland Expo Center. Info at [nmra2015.org/trainshow](http://nmra2015.org/trainshow).

## SELECTED EVENTS | 3

**VIRGINIA, VIRGINIA BEACH**, September 19-20, Tidewater Division 26th Annual Train Show, at Virginia Beach Convention Center, 1000 19th Street. Info at [nmra-mer-tidewater.org](http://nmra-mer-tidewater.org).

### Future 2015 and beyond (by location)

**CANADA, ONTARIO, BRAMPTON**, October 3-4, Annual Brampton Model Railway Show with 33,000 square feet of display including N, HO, O and G scale operating equipment. At Brampton Fairgrounds, 12942 Heart Lake Road. Info at [bramptonmodelrailwayshow.com](http://bramptonmodelrailwayshow.com).

**CANADA, QUEBEC, LAVAL**, Oct 3-4, The North Shore Train Show, Complexe Multi-Sports, 955 ave Bois-de-Boulogne. Info at [salondutrainrivenord.org/english.html](http://salondutrainrivenord.org/english.html).

**CANADA, QUEBEC, MONTREAL**, September 26-27, Model Train Exposition, at Sun Youth Centre, 4251 St Urbain Street. Info at [montrealmodeltrainexposition.com](http://montrealmodeltrainexposition.com).

**ARIZONA, SCOTTSDALE**, September 16-20, NMRA Pacific Southwest Region Convention, at McCormick Scottsdale Hotel, 7401 North Scottsdale Road. Info at [psrnmra.org](http://psrnmra.org).

**COLORADO, LONGMONT**, December 11-13, 38th Annual Model Railroad Expo, at Boulder County Fairgrounds, Hover & Nelson Roads, sponsored by Boulder Model Railroad Club. Info at [bouldermodelrailroadclub.org](http://bouldermodelrailroadclub.org).

**GEORGIA, KENNESAW**, September 18-19, Atlanta Railroads Prototype Modelers Meet, at the Southern Museum of Civil War and Locomotive History, 2829 Cherokee Street. Jointly presented by SRHA, Atlantic Coast Line & Seaboard Airline Railroads Historical Society, Central of Georgia Railway Historical Society, Louisville and Nashville Historical Society, and Nashville Chattanooga & St. Louis Preservation Society. Info at [srha.net](http://srha.net).

## SELECTED EVENTS | 4

**INDIANA, SOUTH BEND**, September 11-12, NMRA Michiana Division Education & Training Conference, at Comfort Suites University Arena. Info at [michiana-nmra.org/events](http://michiana-nmra.org/events).

**ILLINOIS, LISLE (Naperville)**, October 22-24, 22nd Annual Naperville RPM Conference, hosted by Joe D'elia, at Sheraton Lisle-Chicago Hotel, 3000 Warrenville Road. Info at [railroadprototypemodelers.org/naper\\_meet.htm](http://railroadprototypemodelers.org/naper_meet.htm).

**NEBRASKA, NORTH PLATTE**, September 18-20, Rail Fest 2015, info at [nprailfest.com](http://nprailfest.com).

**OHIO, DAYTON**, November 7-8, 40th Annual Dayton Train Show, at Hara Arena, 1001 Shiloh Road. Info at [daytontrainshow.com](http://daytontrainshow.com).

**OHIO, WEST CHESTER**, October 10, NMRA Mid-Central Region, Cincinnati Division 48th Annual Model Railroad Show at Lakota West High School, 8940 Union Centre Blvd. Info at [www.cincy-div7.org](http://www.cincy-div7.org). For table rental information contact Roy Hord at (513) 777-5337 or [rhord@fuse.net](mailto:rhord@fuse.net).

**TEXAS, FOREST HILLS**, October 10-11, Texas Western Model Train Show, presented by the Texas Western Model Railroad Club, at Forest Hill Civic Center, 6901 Wichita Street. Info at [twmrc.org](http://twmrc.org).

**TEXAS, HOUSTON**, September 2-5, 35th National Narrow Gauge Convention. Info at [nngc-2015.com](http://nngc-2015.com).

**TEXAS, SAN ANTONIO**, November 21, Texas Train Show, at Christopher Hall, 16002 Thousand Oaks Drive. Info at [texas-trainshow.net](http://texas-trainshow.net).

**VIRGINIA, FREDERICKSBURG**, September 25-26, 3rd Annual Mid-Atlantic RPM Meet, at Wingate by Wyndham Fredericksburg, 20 Sanford Drive. Info at [marpm.org](http://marpm.org).

# HobbyOn

Come & See Us  
CLICK Here



[www.hobby-on.com](http://www.hobby-on.com)

**Name Brand  
Hobby  
Products  
at Discount  
Prices!**

MRHMAG.COM

## SELECTED EVENTS | 5

Future 2016 and  
beyond (by location)

**CANADA, BRITISH  
COLUMBIA, SALMON  
ARM**, June 15-19, 2016, Pacific  
Northwest Region Annual  
Convention and Train Show.

**COLORADO, DENVER**,  
2017, National Narrow Gauge  
Convention.

**INDIANA, INDIANAPOLIS**,  
July 3-10, 2016, NMRA  
National Convention and  
National Train Show. Info at  
[nmra2016.org](http://nmra2016.org).

**MAINE, AUGUSTA**, Sept.  
7-10, 2016, 36th National  
Narrow Gauge Convention.  
Info at [nngc2016.org](http://nngc2016.org). ■



Click here for  
reader comments



CLICK  
HERE FOR  
MORE  
INFO



**JUST TWO OF SEVEN  
DIFFERENT ENDS ON OUR RDC-1**

- TABLE OF CONTENTS
- INDEX



## Clickable advertiser index – 1

[Accu-Lites](#)  
[American Ltd \(San Juan\)](#)  
[ANE Models](#)  
[Archer Fine Transfers](#)  
[Athearn](#)  
[Atlas Model Railroad Co.](#)  
[Bachmann](#)  
[Backdrop Junction](#)  
[Berrett Hill Trains](#)  
[Black Cat Publishing](#)  
[Blair Line](#)  
[BLMA](#)  
[Bowser](#)  
[Caboose Hobbies](#)  
[Canyon Creek Scenics](#)  
[Clever Models](#)  
[Coastmans Scenic Products](#)  
[Coffman Graphics](#)  
[DCC by Design](#)  
[Digitrax \(2 page spread\)](#)  
[ESU LokSound](#)  
[Fast Tracks](#)  
[Fifer Hobby Supply](#)  
[Fox Valley Models](#)  
[George's Trains](#)  
[GLX Scale Models](#)  
[Grand Central Model Railway](#)  
[Great Decals](#)  
[Hobby-On \(MRS Hobby\)](#)  
[Iowa Scaled Engineering](#)  
[Iwata-Medea](#)  
[Jelsma Graphics](#)

[Ken Patterson](#)  
[Lights 4 Models](#)  
[Litchfield Station](#)  
[Logic Rail Technologies](#)  
[Microscale](#)  
[Missouri Pacific Historical Society](#)  
[Model Railroad Benchwork \(1\)](#)  
[Model Railroad Benchwork \(2\)](#)  
[Motrak Models](#)  
[Mountain Subdivision Hobbies](#)  
[MRH Store \(Model Trains Video\) \(1\)](#)  
[MRH Store \(Model Trains Video\) \(2\)](#)  
[MRH Store \(Model Trains Video\) \(3\)](#)  
[Nano-Oil](#)  
[National Narrow Gauge Conv.](#)  
[NCE \(2 page spread\)](#)  
[Nick & Nora Design](#)  
[North American Railcar](#)  
[Portland National Train Show](#)  
[Pre-Size Model Specialities](#)  
[Precision Design Co.](#)  
[RailMaster Hobbies](#)  
[Railroad Explorer](#)  
[Rapido \(1\)](#)  
[Rapido \(2\)](#)  
[Ring Engineering \(1\)](#)  
[Ring Engineering \(2\)](#)  
[Rulers-of-the-World](#)  
[Rusty Stumps](#)  
[Streamlined Backshop](#)  
[Scenic Express](#)  
[Scotty Mason Show](#)

## Clickable advertiser index – 2

[Signature Press](#)  
[Soundtraxx \(Blackstone\)](#)  
[Southern Digital](#)  
[TAM Valley Depot](#)  
[Tony's Train Exchange](#)  
[Trainfest](#)  
[TrainMasters TV \(1\)](#)  
[TrainMasters TV \(2\)](#)  
[TrainMasters TV \(3\)](#)

[Traintek](#)  
[TrainWorld](#)  
[True Scene Modeling](#)  
[Voltscooter Engineering](#)  
[Walthers](#)  
[Westerfield Models](#)  
[Yankee Dabbler](#)  
[Yarmouth Model Works](#)

## Clickable "other" index

---

[Other – Bonus Extras](#)  
[Other – Cover](#)  
[Other – Derailments](#)  
[Other – Hobby Marketplace](#)  
[Other – MRH Sponsors](#)  
[Other – Staff Notes](#)  
[Other – Table of Contents](#)

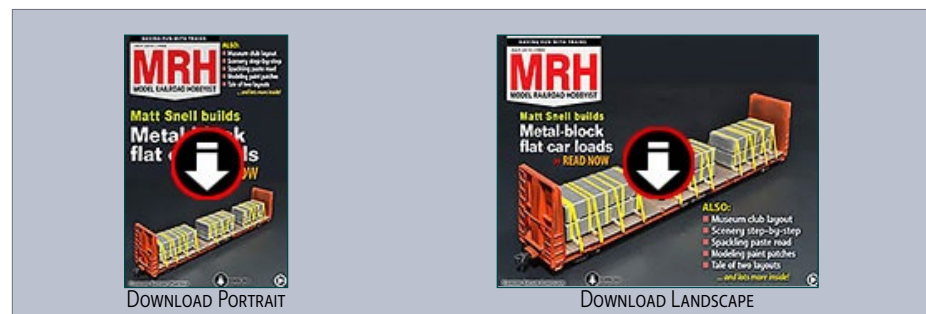



JOE FUGATE  
.....



[Click here for reader comments](#)

## No Use for HOMASOTE ...



**I WON'T BEAT AROUND** the bush, I personally don't have any use for homasote on a model railroad. On my Siskiyou Line layout, I don't have one scrap of Homasote anywhere. Never have liked the stuff – and frankly, never will have it on my layout.

First, I swear the Homasote company saw the model

railroaders coming, since Homasote sells at almost \$30 for a 4'x8' half-inch sheet! By comparison, a half-inch sheet of drywall runs just \$10 for a 4'x8' sheet.

So I went with a plywood / drywall sandwich on my layout's flat areas. I talked to an architect who is also a model railroader and

▶ **STEPPING OUTSIDE THE BOX WITH A CONTRARY VIEW**

asked him which will expand less in the presence of moisture – Homasote or drywall? He said without question drywall will expand less in moisture than Homasote will.

In fact, I've taken to using scraps of drywall as working boards for my projects. It works especially well for doing my Poor man's turnout jig method (see the September 2011 issue of MRH [model-railroad-hobbyist.com/magazine/mrh-2011-09-sep/jig-built\\_turnouts](http://model-railroad-hobbyist.com/magazine/mrh-2011-09-sep/jig-built_turnouts) for more). The drywall holds small track spikes just fine. I just wrap some duct tape around the edges of these scraps and voila! Instant soft workboards for my projects!

Cutting drywall is a snap, literally. Similar to working with styrene, as long as the edge is fairly straight, you can just score it with a sharp utility knife then snap it. Cut through the paper on the other side of the snap and you're done – no mess!

Have you ever cut Homasote with a saw? Prepare for heaps of dust on everything! Yes sir, cutting drywall was never this messy!

I think it was Linn Westcott from *Model Railroader* who first promoted its use. It seems to have become a given that Homasote is the stuff you want for your roadbed and large flat areas for things like yards.

Isn't it about time we kill the Homasote myth as a product that's required in model railroading? The stuff is costly, messy and subject to dimensional changes when exposed to moisture.

Myself, I use hardboard spline for my roadbed, laying the track straight on the spline with grey latex caulk. For large flat areas, using a drywall-plywood sandwich works just fine. My pocket book certainly appreciated the relief.

At this point, my layout's going to be 25 years old in 2016. There's not a scrap of Homasote on the layout anywhere, and I've not missed it, even a tiny bit!



# DERAILMENTS



## FUNNY, WEIRD AND WACKY TRAINS

Not only do you find out why the chicken crossed the railroad tracks in this video (watch to the end to get the answer), but you'll see quite the eclectic mix of unusual and sometimes rather wacky trains.

► BIZARRE FACTS AND HUMOR (SUPPOSEDLY)

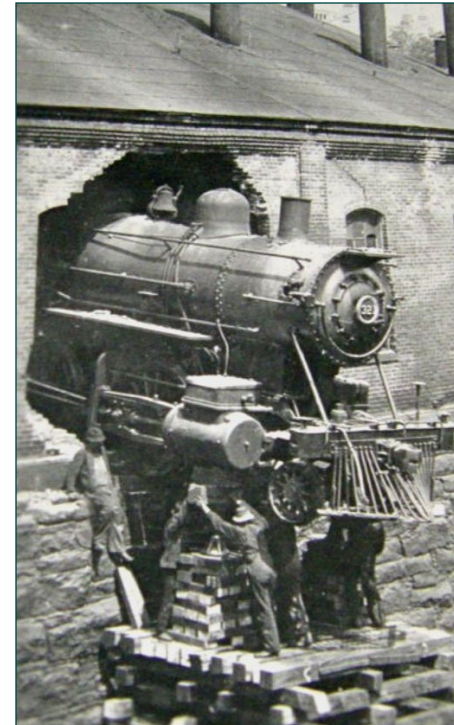

Photo from [The Old Motor website](http://The Old Motor website).

# WHEN I SAY STOP, I MEAN STOP!



[Click here for reader comments](#)

## Coming next issue ...

- Don Hanley on building the Meadow Gold dairy, step-by-step
- Prepping cars for operation
- Making a DCC test track
- Using forced perspective effectively
- Kitbashing / scratchbuilding SP passenger cars
- And lots more ...

