

Building resin cars • SP&S RS-3 • Turnout control

# Model Railroad Hobbyist magazine™

August 2014

Price: Forever Free

**Gary Christensen does ...**

## Realistic “rustbucket weathering”



Click here for the  
landscape version

## HAVING FUN WITH TRAINS



Standard edition - Portrait



download



contents



index

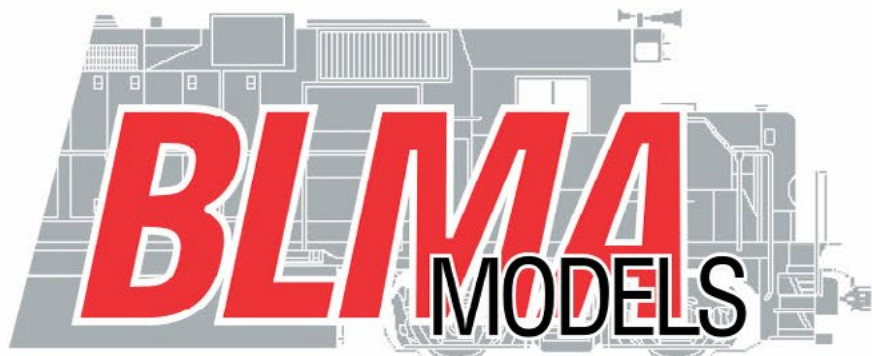

**N**SCALE

*General Steel Castings*  
**60' FLAT CAR**

COMING SOON IN SIX PAINT SCHEMES!

▶ ORDER BY: **September 15th**

▶ DELIVERY BY: **Early 2015**



**CLICK HERE TO SEE MORE**



# Model Railroad Hobbyist magazine™

Issue 54

**Front Cover:** Soo 16916 rolls along in a freight heading south towards Los Angeles, where it will deliver its load. The model was weathered by Gary Christensen: follow as Gary show us how to do “rustbucket weathering”.

**ISSN 2152-7423**

## Editorial Staff

Joe D. Fugate, Publisher and Editor  
Don Hanley, Assistant Editor

## Production

Patty Fugate, pasteup and layout  
Joe Brugger, copy editing  
Mike Dodd, copy editing

## Technical Assistants

Jeff Shultz  
Jimmy Simmons

## Advertising

Les Halmos, Account Manager  
Daniel Nava, Advertising Assistant  
Jean-François Delisle, Marketing Assistant

Published for the glory of God. [What's this?](#)



## Columnists

Richard Bale, News and events  
Jeff Shultz, News and events  
Les Halmos, Modular railroading  
Ken Patterson, Reporter at large  
Bruce Petrarca, DCC

## Special Correspondents

Joe Brugger, Questions & answers  
Charlie Comstock, Contributing editor

Issue password: Aug2014

Cover and MRH masthead



contents



index



click to learn more about this sponsor



click to learn more about this sponsor



**NEW SPONSOR!**



**NEW SPONSOR!**



**NEW SPONSOR!**



click to learn more about this sponsor



click to learn more about this sponsor

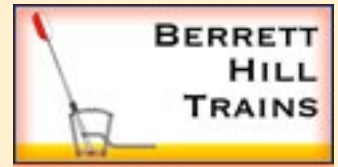

**NEW SPONSOR!**



**NEW SPONSOR!**



**NEW SPONSOR!**



click to learn more about this sponsor



click to learn more about this sponsor



**NEW SPONSOR!**



click to learn more about this sponsor



click to learn more about this sponsor



click to learn more about this sponsor



click to learn more about this sponsor



click to learn more about this sponsor



click to learn more about this sponsor



click to learn more about this sponsor



click to learn more about this sponsor



click to learn more about this sponsor



**NEW SPONSOR!**



click to learn more about this sponsor



click to learn more about this sponsor



click to learn more about this sponsor



click to learn more about this sponsor



**NEW SPONSOR!**



**NEW SPONSOR!**



click to learn more about this sponsor



click to learn more about this sponsor



**NEW SPONSOR!**



click to learn more about this sponsor



click to learn more about this sponsor



**NEW SPONSOR!**



click to learn more about this sponsor





click to learn more about this sponsor



click to learn more about this sponsor



click to learn more about this sponsor



**NEW SPONSOR!**



click to learn more about this sponsor



click to learn more about this sponsor



**NEW SPONSOR!**



click to learn more about this sponsor



**NEW SPONSOR!**



click to learn more about this sponsor



click to learn more about this sponsor



**NEW SPONSOR!**



click to learn more about this sponsor



**NEW SPONSOR!**



click to learn more about this sponsor



click to learn more about this sponsor



click to learn more about this sponsor



**NEW SPONSOR!**



click to learn more about this sponsor

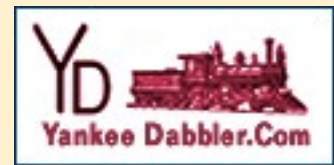

click to learn more about this sponsor

**100,000+ unique device views per month...**

**Tell me more**

**Want your logo on this page?**

*Click to find out how....*

**MRH HOBBY MARKETPLACE - 1**      **MRH HOBBY MARKETPLACE - 2**

MRH May 2014 MRH Hobby Marketplace - 1      MRH Hobby Marketplace - 2

**Looking for something? Check our Hobby Marketplace!**

**Take me there**



# Table of Contents - 1

## Main Features

Click title  
to view



### “Rustbucket weathering”

Extreme car weathering without an airbrush  
*by Gary Christensen*



### Building your first resin house car

Tips and tricks for building limited run kits  
*by Rob McLearn*



### Realistic switch control

The fun of using large-scale switch stands  
*by Trevor Marshall*

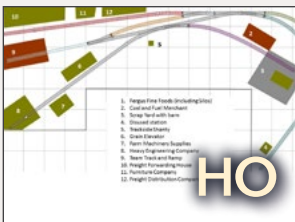

### \$500 contest winner 2nd place

Build this layout for under \$500  
*By Robert Douglas*



### Intro to 3D modeling

A new method for creating special parts  
*by Earl Hackett*



### First Look: SP&S RS-3 in N

A common Alco switcher in N-scale  
*by Hobbysmith*

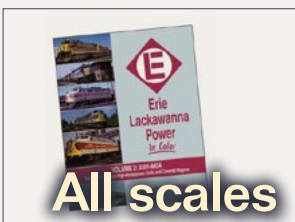

### August Hobby News

Industry news, product announcements, and events  
*by Richard Bale & Jeff Shultz*



## Table of Contents - 2

# Other Features

*Click title  
to view*

**Report from Cleveland**

**Assistant Editor's thoughts**  
*by Don Hanley*

**MRH Staff Notes**

**EBooks like you've never seen**  
*by the MRH staff*

**MRH Q - A - T**

**Questions, Answers, and Tips**  
*compiled by Joe Brugger*

**Yes it's a model**

**Great modeling photo feature**  
*compiled by the MRH Staff*

**Hobby Marketplace**

**Vendor ads**

**Derailments**

**Bizarre facts / humor (allegedly)**

# Columns

**HO sound DCC installation**

**DCC Impulses**  
*by Bruce Petrarca*

**Layout building productivity**

**Getting Real**  
*by Mike Rose*

**Finishing the coal tibble**

**Lite and Narrow**  
*by Larry Smith*

**Signal tower scene design**

**What's Neat**  
*by Ken Patterson*

**The case against detail**

**Reverse Running**  
*by Joe Fugate*

**Subscriber-only extras** (*subscribers click here to access*)





**HO SCALE**  
[CLICK HERE](#)





# EMD FL9



**N SCALE**  
CLICK HERE



Email



Phone



contents



index

ATHEARN®: TRAINS IN MINIATURE™



**PREORDER NOW**



HO Locomotive

## COMPLETELY REDESIGNED SD40. INSIDE AND OUT.

The EMD SD40 changed the face of American Railroading. From 1966-1972 the SD40 was produced for many different railroads before being updated to the SD40-2. The SD40-2 saw delivery 1972-1989 as the successor to the game changing SD40. Both versions lead a new paradigm of 3000 horse power locomotives becoming the standard model for a full motive power generation. Many of these signature locomotives can be found today.

We are excited to bring you a similar game changing paradigm shift – the completely redesigned and completely new Ready to Roll EMD SD40 from Athearn. Along with a brand new shell comes a new mechanism that can be upgraded to our Genesis electric motor. Locomotives come not just DCC ready, but SOUND ready. This will be the FIRST series of RTR Locomotive models that also feature factory installed SOUND!

Three points of perfection:



Completely new hood, handbrake location according to prototype, new dynamic/non dynamic brake hatches and optional early or FARR style radiator grilles.



Nose – no boundaries. The correct nose and headlight/signal light configuration for the right prototype.



New chassis not only makes this model a smooth runner, but includes a baffle for a speaker and enough space to upgrade to Genesis™ power with kit ATHG63839.



Find us on: YouTube®  
Facebook® and Twitter®

**HORIZON**  
HOBBY

**VISIT**  
Your Local Retailer

**CLICK**  
Athearn.com

**CALL**  
1.800.338.4639

**SERIOUS FUN.®**

©2014 Horizon Hobby, LLC. Athearn and Genesis are registered trademarks of Horizon Hobby, Inc. The Union Pacific mark and other marks owned by Union Pacific are made under trademark license from Union Pacific Railroad Company. All other trademarks, service marks and logos are property of their respective owners. Final models may vary slightly from photos shown. 46288





# Cleveland 2014

Convention inspires new layout thoughts



## Assistant Editor's thoughts

by Don Hanley

**I**t is over – the 2014 NMRA National Convention is history. For those who were unable to attend, you missed a great event. I have been to regional meets and RPM meets before, but this was my first time attending a national convention.

I want to congratulate the Cleveland team: they did a marvelous job. From my perspective, everything ran very smoothly. The event was held in the new Cleveland Convention Center and was the first event held there. The convention center staff likewise did a great job, and are to be commended as well. The only problem was parking. That had to do with the city and there wasn't much the convention committee could do about that.

I began my time at the convention on Wednesday, taking in the LD/OPS SIG layout tour. I found all the layouts worthy of being part of this exclusive tour. All layouts were operational, with scenery ranging from minimal to fully sceniced. I noticed each owner housed their layout in a neat clean room, and allowed space for visitors. Each owner had achieved what I discussed in my editorial a year ago on doing a layout room well (see: [mrhpub.com/2013-08-aug](http://mrhpub.com/2013-08-aug)). I left each layout a bit sorry that I had to leave such a pleasant environment.



**HO**  
SCALE



*Ken Paterson*

PRR - TUSCAN RED 5 STRIPE #4913  
Item No. 65302

  
**CLICK HERE  
TO WATCH  
THE VIDEO**

# **ELECTRIFYING NEWS BACHMANN'S SOUND VALUE GG-1 STARS IN VIDEO!**

The electric GG-1 has a unique streamlined design that captured the public's imagination when it was introduced in the 1930s. Our GG-1 is loaded with features to spark your interest, including all new tooling, die-cast frame, 12-wheel drive, twin operating metal pantographs that can operate from overhead wire if desired, soft white LED directional headlights with dimming function, and *E-Z Mate*® Mark II couplers. This DCC sound-equipped model includes our Sound Value *SoundTraxx*® sound package with prototypical motors with blowers, pantograph extension and retraction, air compressors, short and long horns, and bell—all in 16-bit polyphonic sound. It is also available in a DCC-ready version with an 8-pin socket ready for DCC decoder installation of your choice. Visit your favorite hobby dealer to see why the arrival of the GG-1 is such electrifying news for HO modelers!

Click to learn more. 



**Shipping Now!**  
MSRP \$299.00 each



PRR - BRUNSWICK GREEN  
SINGLE STRIPE #4807  
Item No. 65301



PRR - "BLACK JACK"  
BRUNSWICK GREEN 5 STRIPE #4935  
Item No. 65303



PRR - SILVER with RED STRIPE  
"CONGRESSIONAL" #4872  
Item No. 65304



PENN CENTRAL - BLACK  
with WHITE LETTERING #4853  
Item No. 65305



Bachmann Industries, Inc. • 1400 East Erie Avenue • Philadelphia, PA 19124 USA • [www.bachmanntrains.com](http://www.bachmanntrains.com)

Click to learn more.

MRH-Aug 2014



I found the number of clinics and their variety to be impressive. I attended as many clinics as I could, but there were more than one individual could possibly attend. One room difficult to stay away from was the contest room – the room held some very impressive modeling.

The National Train Show ran from Friday through Sunday in the convention exposition center. Of this large spacious area, the show devoted a generous amount for layouts. The layouts ranged from Proto 48 to Z, three-rail O gauge to Sn2, HO and N. There was even a 7-1/2" gauge live-steam locomotive on display!

Several groups displayed FreeMo layouts: single track mainline, a two-track mainline, or a two-track main with a branch line. The modules or sections followed all manner of shapes and sizes. One HO group had a 24' radius curve (yes, 24 feet) that made up one corner. Try that on a home layout! Watching the trains go around this broad curve is just something you don't see very often.

*Advertisement*



WORLD FAMOUS  
MODEL TRAIN STORE

Since 1938!

**The World's  
Largest  
Model Train Store!**

Model trains G to Z, DCC, brass models, kits, RTR, collectable models, scenery, structures, books, magazines, DVD's, hobby tools & supplies and a full service repair department.



**WWW.CABOOSEHOBBIES.COM**



Some of the larger layouts involved two or three different clubs combining their modules to form one massive layout. All together, I counted over 640 individual modules on display at this show!

This got me thinking about the convention and how we build layouts in the hobby. It seems to me sectional/modular layout construction has gained a solid foothold.

Many of us do not have space, nor will we ever have the space to build the layout of our dreams. Those who do have lots of space often become overwhelmed with scope of such a project.

Sectional layout construction need not be limited to portable layouts. You can use the same approach on a home layout. Publisher Joe Fugate talks a lot about the value of sectional layout construction, and it makes sense.

By building your home layout in sections, you create the flexibility to remove a section and take it to the workbench to repair it or to flip it over to do things like mount switch machines. No need to crawl under the layout, which becomes more difficult the older we get.

You also have the ability to do most of the messy work outside the layout room, helping to keep the layout room neat and clean. Think about the advantage of having your necessary tools and supplies located on the workbench instead of being scattered around the layout.

Two of the displays in the contest room (also called the “celebration room” for those less into competition) featured sectional portions of an individual’s home layout. These sections included labels showing where they connected into the layout, so no confusion when the section made its way back home. The only limitation you need to keep in mind is that the section must fit through the smallest door, or around the tightest corner you have.

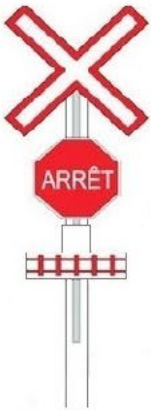
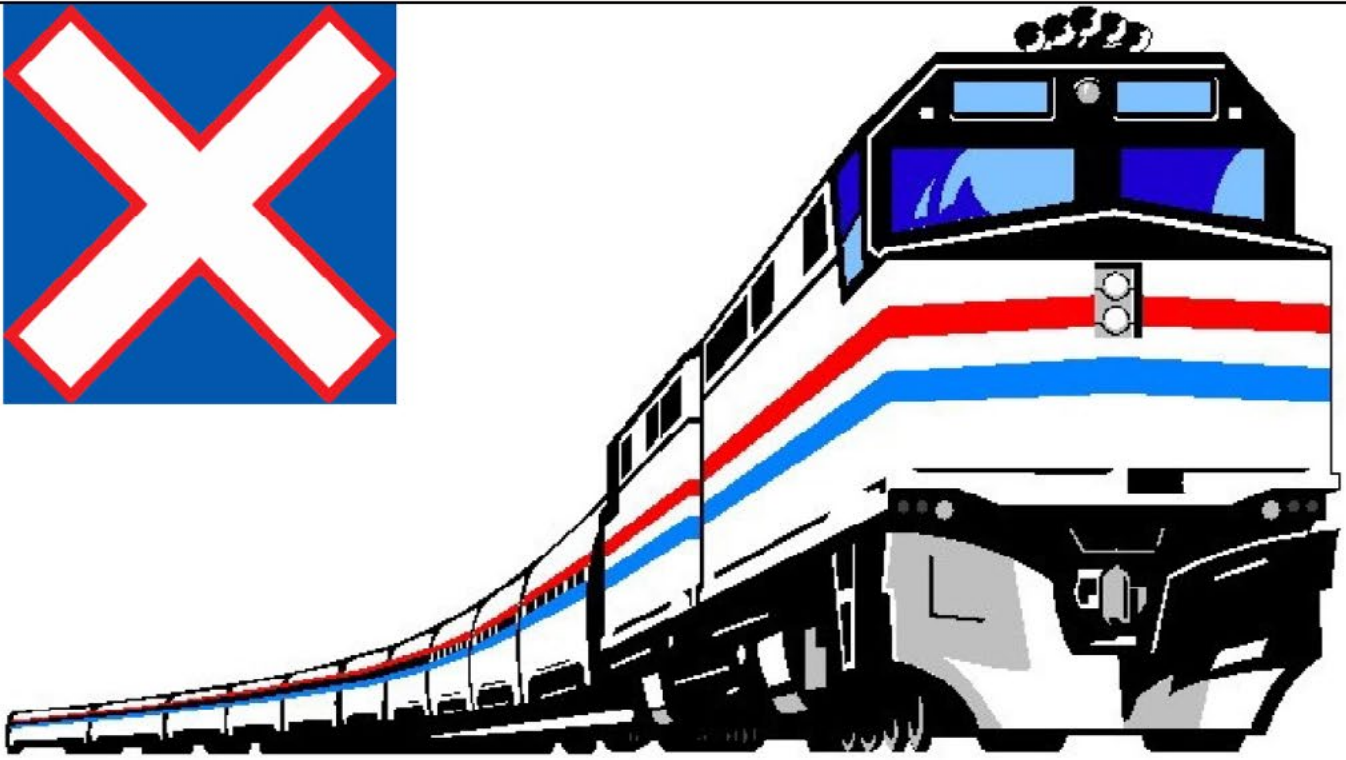

# THE NORTH SHORE TRAIN SHOW

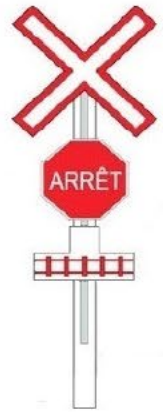

**First Edition**

**OCTOBER 4 & 5 OCTOBRE  
2014**

**SATURDAY**

**10AM TO 5PM**

**SUNDAY**

**9:30AM TO 4:00PM**

**Complexe Multi-Sports**

**995 ave Bois-de-Boulogne  
Laval ,Québec  
Canada**



Email



Phone



contents



index

A big advantage of building your layout in sections – you are less likely to become overwhelmed. You can see a portion of the layout completed, moving it from your imagination into reality more quickly because it has a well-defined scope.

I spoke with a modeler at the show who had experienced just that. He attempted to build a large home layout several times, but due to moves and frustration with damage to his previous work, he was ready to leave the hobby.

But when he hooked up with others who wanted to build a portable layout, he found fresh excitement in the hobby. He said that being able to see a small section go from a pile of lumber to a completed scene with trains running through it in fairly short order provided that new sense of accomplishment for him. He has never been happier with the hobby.

Remember Joe's one-section challenge [mrhpub.com/2013-05-may](http://mrhpub.com/2013-05-may)? Once you have completed the section, put it in the layout space with staging on each end. Once that has been

*Advertisement*

# Railroad Explorer Magazine

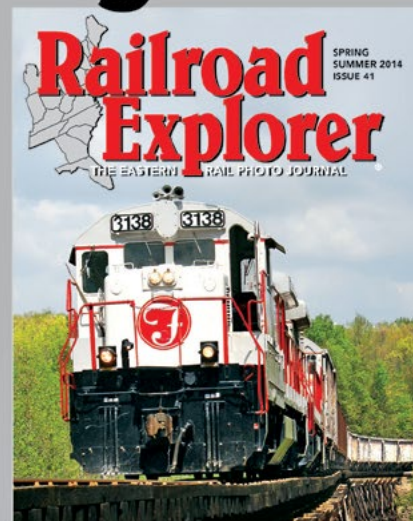
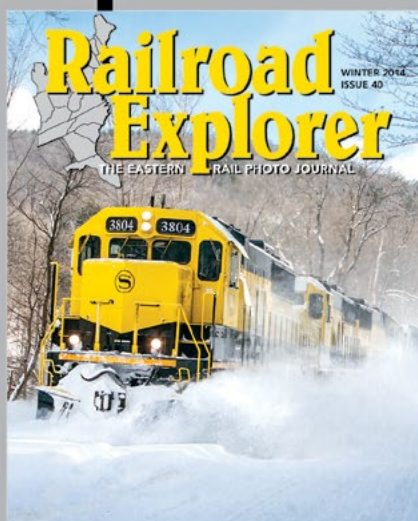
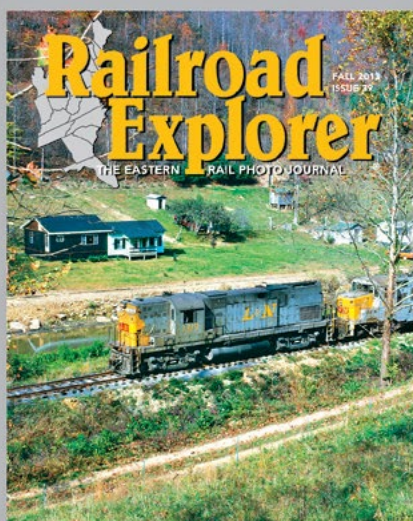

## THE EASTERN RAIL PHOTO JOURNAL

- Three all-color issues per year. Exciting feature stories and spectacular photos of Eastern Railroading
- Best-in-class photo reproduction. Printed on heavy, glossy paper. Zero advertising.
- Three times per year - Winter, Spring/Summer and Fall editions.

**Subscribe today!**

[www.railroadexplorer.com](http://www.railroadexplorer.com)

MRH-Aug 2014







New Clinics are being added daily!!  
Check the website for all the latest news!!

## 34th National Narrow Gauge Convention September 3rd-6th, 2014

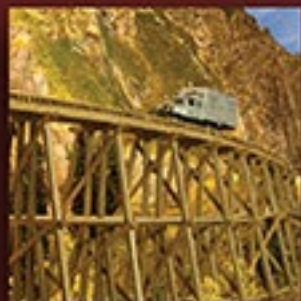

### Goin' to Kansas City

Come and enjoy the sites and sounds of Kansas City and our fantastic Narrow Gauge community. See what we have to offer and get the creative juices flowing - all while enjoying great food, great people and a great city.

We will have:

- Over 400 Vendor and Manufacturer Tables
- Exciting new Clinics and Clinicians
- 60,000 square foot state-of-the-art convention hall
- Hotel and Convention Center in one location
- Dozens of layouts on the Layout Tour
- Free Wi-fi for all Convention Attendees



**CLICK HERE**  
[www.34thnngc.com](http://www.34thnngc.com)

### GREAT AREA ATTRACTIONS

Union Station, Truman Library, Steam Ship Museum, Power and Light District, the Country Club Plaza and GREAT BBQ are just a few of the things that KC is known for.

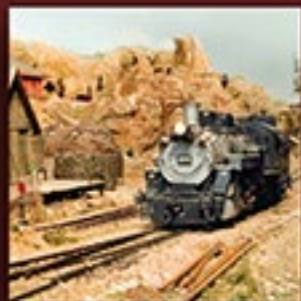

### REGISTRATION

Attendees can REGISTER ONLINE at [www.34thnngc.com](http://www.34thnngc.com)  
Registration: \$99 (\$114 after June 1, 2014)  
Email: [registrar@34thnngc.com](mailto:registrar@34thnngc.com)  
Address: 34th NNGC  
14633 S. Chalet Dr.  
Olathe, KS 66062

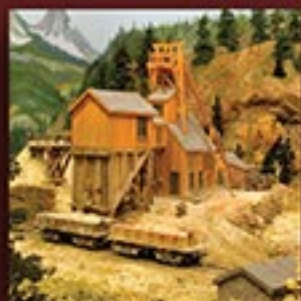

### EXCITING NEW CONTEST CATEGORY

In addition to all the contest categories that you are used to, there will be a special contest category:  
**- THE SQUARE FOOTER -**  
Build anything you want as long as it fits on a 12" x 12" display

### CONVENTION HOTEL

Rooms are filling fast...  
Check the website for current hotel availability.

## We want to see you in KC!!



contents



index

# NEW for AUGUST

**87-1482 & 60-1482**  
Conrail (CR)  
Open Top Coal Hoppers



**87-1483 & 60-1483 (BLACK)**  
**87-1484 & 60-1484 (WHITE)**  
NAHX and TLCX, PTLX, PLCX Style  
Reporting Marks and Alphabet  
For PD 3000 and PS 4740 and 4750  
Covered Hoppers

**87-1483 & 60-1483 (BLACK)**  
**87-1484 & 60-1484 (WHITE)**  
NAHX and TLCX, PTLX, PLCX Style  
Reporting Marks and Alphabet  
For PD 3000 and PS 4740 and 4750  
Covered Hoppers



**87-1485 & 60-1485**  
Delaware & Hudson (D&H)  
Assorted Passenger Cars  
Includes Stripes and Car Names

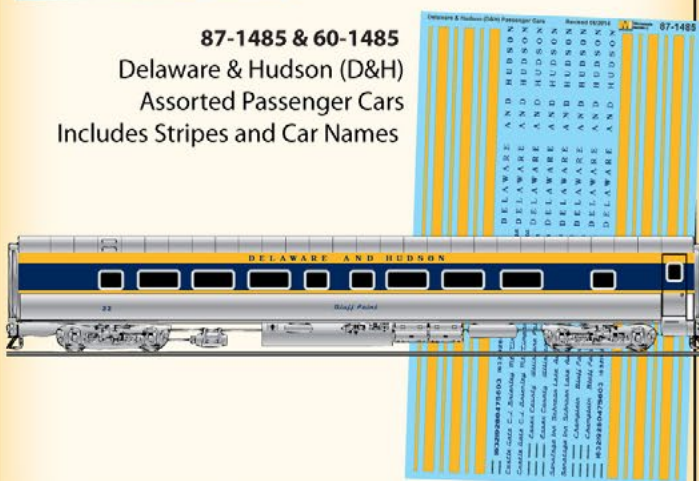

**87-1486 & 60-1486 (BLACK)**  
**87-1487 & 60-1487 (WHITE)**  
Well Car Common Data

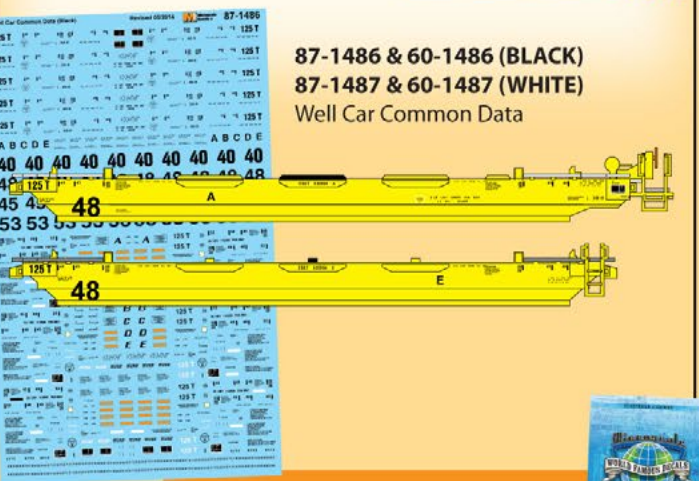

Click to View Online Catalog

Microscale Decals® microscale.com MROC IN THE USA

completed, do another, and then another.

No matter how disciplined you may be, it's difficult to stay with a project if there's no end in sight. And that's the problem larger layouts, the end can be so far in the future we can't stay motivated enough to make good progress.

So is the larger home layout a bad idea? Not at all! What may be time to lay to rest, however, is our approach to how we build such larger layouts. Instead of one massive layout project, how about taking it just one section at a time?

**Reader Feedback**  
(click here)



New Innovation



# Nano Technology Lubricants

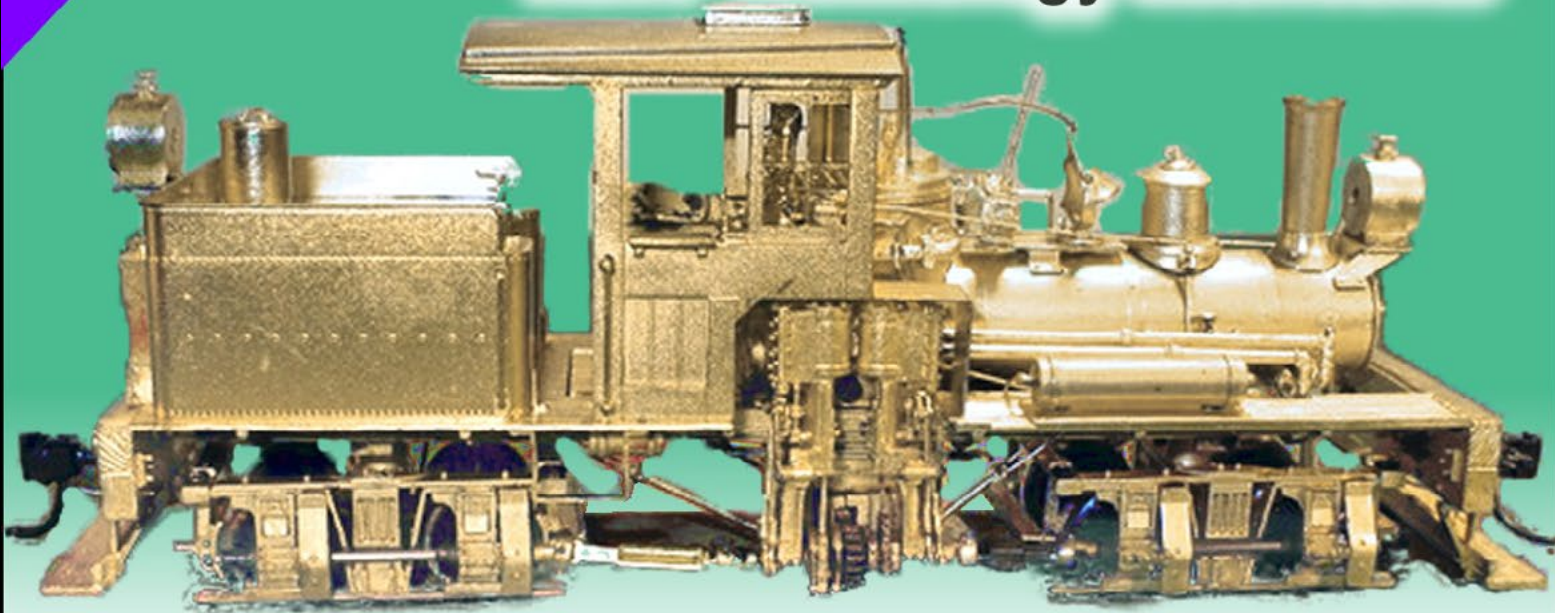

**Nano-Grease**

"After eight years of extensive testing, the only lubricants now used in my shop are Nano-Oils and Nano-Grease. The extreme reduction in power draw by mechanically minimizing friction is simply technologically superior."

- Phil Floyd, 'The Shay Fixer'



**THE SHAY FIXER**  
 VISIT US AT...  
**SHAYFIXER.COM**

*Specializing in brass Pacific Fast Mail / United geared locomotives*

**For more details  
click here ...**



# Notes from the MRH STAFF

EBooks like you've never seen, MRH is digital first, Made for sharing, Yes, MRH is indexed, and more ...



## Coming: eBooks like you've never seen!

**W**e're about to kick our new eBooks division into high gear, so we thought it would be good to give you a preview of what's coming.

We're pretty excited about all the great eBook titles we have in the hopper, and we'd like to also discuss how we believe eBooks for model railroaders need to be done. So far, we're the only publisher in the model railroad industry doing eBooks this way.

But first, let's talk about what eBooks we have coming.

**Railroad Explorer #41, Summer 2014:** Railroad Explorer has been our first eBook title, and it's essentially a photo essay periodical without ads. It's loaded with superb photos of eastern prototype diesels



# iwata

by ANEST IWATA

## *Just Rolling By...*

## Make It **REAL** With Iwata *Climb Aboard!*



**Eclipse  
HP - CS**



**Revolution  
HP - TR1**



## **Visit...** [www.iwata-medea.com](http://www.iwata-medea.com)

## **To Check Out Our Full Product Line!**

*Models By... Alan Houtz,  
North American Prototype Modelers*



contents



index



## July 2014 MRH Ratings

The five top-rated articles in the [July 2014](#) issue of MRH are:

- 4.6 What's Neat: An electronic fly swatter?
- 4.5 Track cleaning experiments
- 4.5 DCC Impulses: More getting the sound out
- 4.5 Up the Creek: Laminated backdrop
- 4.4 Computer-generated backdrops
  
- Issue overall: 4.3

***Please rate the articles!***

Click the reader feedback button on each article and select the star rating you think each article deserves. ***Thank you!***

Advertisement

## Check out the latest Atlas All Scales Catalog!

**View and pre-order all of the  
latest locomotive and freight  
announcements from Atlas now!**

**CLICK HERE!**

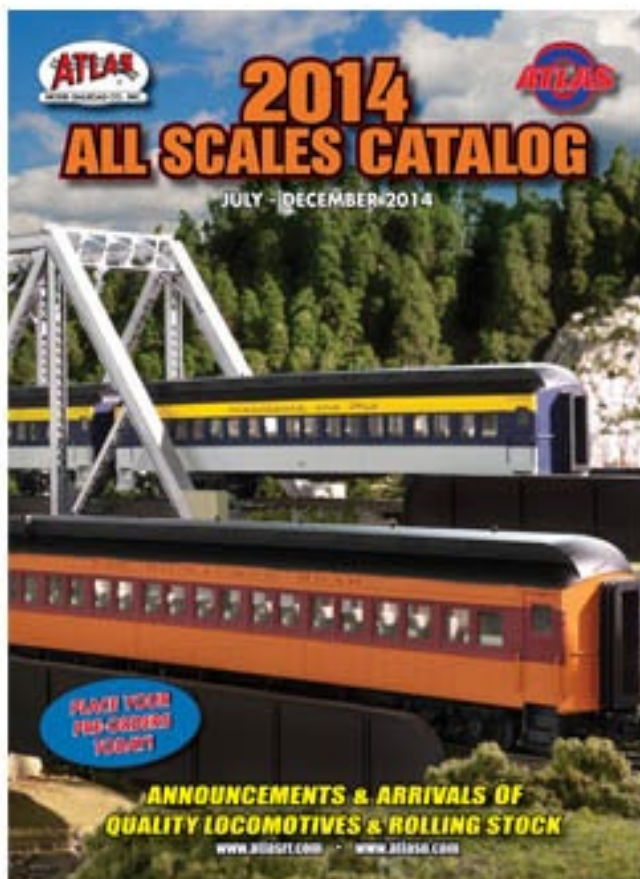

MRH-Aug 2014



from the 1960s to present, along with railfan stories. Mike Confalone (of the Allagash Railway fame) is the editor. Mike publishes a paper edition of this periodical, and he's having us do the digital version. *Railroad Explorer* (RREX) has been our first foray into digital eBooks, and we've cut our teeth on RREX, defining our unique approach to eBooks for modelers. More on this later.

**Easy Real Railroads:** Robert Schleicher, past editor of *RailModel Journal*, has a great

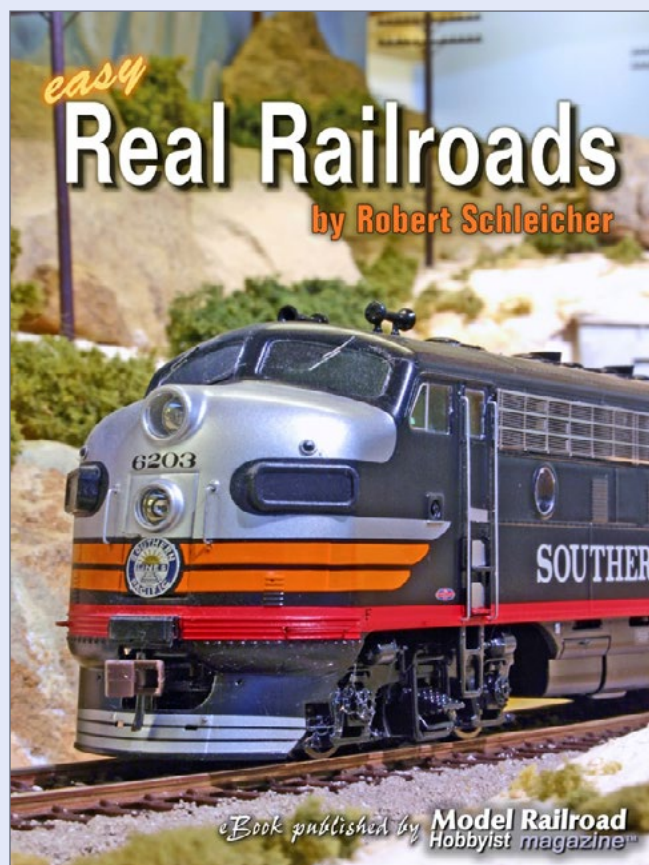

**Easy Real Railroads**, a new eBook series by Robert Schleicher, coming from the MRH Store.

### Advertisement

Summer is here, time to GO FISHING!

Frank's Fishing Shack  
Kit # ST010  
\$28.95

Craftsman structures  
Detail Parts  
Shingles  
Vehicle kits from:  
Sylvan & Jordan  
Tru-Color paint



NICK & NORA DESIGNS  
Uniquely inspired craftsman kits



**When talking to hobby vendors, please remember to mention MRH.**



new book series he's written on doing prototype modeling by example. Bob covers the thinking you need to go through if you want to do a prototype-based railroad well, and then he provides several layouts as examples, discussing the hows and whys of each prototype-based layout.

**Building an HO steam locomotive in brass and styrene:** René Gourley has an eBook he did on scratchbuilding an HO steam loco, and he's updated it with new material and is having us publish it. René goes step-by-step through the construction process, and we think you'll find this book to have many useful tips for any steam loco construction project you may wish to undertake.

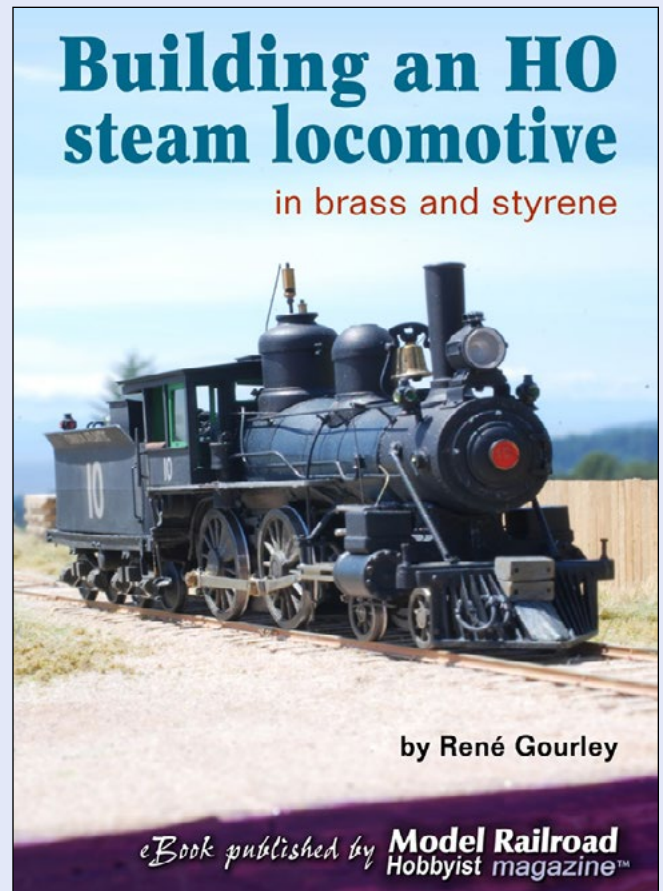

### **Early wood frame and stone/**

**masonry structures:** Pat Harriman, an MMR and architect, has developed 86 structure plans and made them available for publication. We'll be publishing them in an eBook series we're working on now. You can also find a layout visit with Pat on TrainMasters TV at:

[trainmasters.tv/videos/2014-05-4-tmtv-may-2014-edition-act-iv](http://trainmasters.tv/videos/2014-05-4-tmtv-may-2014-edition-act-iv)

**Other eBook titles coming:** The eBooks listed above should be coming throughout the fall, with a number of other eBooks planned for 2015. The eBook titles planned for 2015 include:

- ***All about the Railway Express Agency*** by Victor Roseman
- ***Make it run like a dream*** (series) by Joe Fugate
- ***Railroad Explorer #42, 43, and 44*** edited by Mike Confalone





We're also talking with the Operations SIG about publishing one or more books on operations – stay tuned on that front.

## The MRH eBook difference: Digital first

While the other model railroading publishers are starting to explore digital publishing, they're not approaching digital eBook publishing the same way we are. With us, we're digital first, while the other guys are very much print first.

What difference does that make, you ask? It makes a lot of difference, actually. In this case, a picture is worth a thousand words, so let's just *show you* the difference.



**200% zoom: "other guys" digital book, \$10.95**



**200% zoom: MRH Store digital book, \$5.99**

In short, good photographs matter to modelers, and we make sure you can zoom into the digital images and study the details up close. See the next couple pages for some full-spread examples.

The other guys see eBooks as a secondary add-on to their print-first business, and they don't really understand digital like we do. As if that wasn't enough, they're also generally charging more for what is a lower-quality product than what MRH gives you.



contents



index



10. **Above:** Norfolk, Franklin & Danville's daily eastbound freight trundles through rural south (NKP) RS-11s and a leased T-6 from parent N&W. The lead unit was built for the NKP in 1956

***Full screen example #1 from MRH's Railroad Explorer***



 **Get this eBook!**



contents



index



17. Above: Led by big Alco Century 630s 5309 and 5306, Reading symbol BH-15 heads westward on the Reading Line. This train of mostly empties is bound for Rutherford Yard near Harrisburg, PA and a re

**Full screen example #2 from MRH's Railroad Explorer**



 **Get this eBook!**



contents



index

The preceding pages are screen grabs from a PC displaying the Kindle edition of Railroad Explorer #40. I displayed the book full screen in the PC Kindle reader, and I got what looks like a digital coffee table book with page after page of breathtaking photography.

Mike Confalone emailed this to us when he took a look at Railroad Explorer #40:

*“Absolutely spectacular ... it’s beyond impressive.”*

So this is what you get when you buy an eBook from us. We like to say of our eBooks: “no ads, just page after page of superb photographs”.

In general, our eBook content is all-new material and we bring it to you completely ad-free. And as you can tell, we price our eBooks to be very affordable. [Visit the MRH eBook store.](#)

## **August 2014 Bonus Extras!**

***Available to subscribers!***

**DVD and HD quality versions:**

- **DCC sound install tip videos**
- **August *What’s neat this week* video**
- **Realistic turnout control demo video**

**Click here to access**



## Speaking of eBooks, they're also coming to TrainMasters TV

That's right, we're expanding the scope of what TMTV members will be getting as part of their membership to include eBooks. About 6 months after we release select eBook titles, they will then become available to TMTV members for free online viewing just like the online edition of Model Railroad Hobbyist.

TMTV members already get streaming HD versions of the DVD titles we release about 6 months after release, so here's one more great benefit of being a TMTV member!

***Also, we're running an August special on the annual subscriptions this month, so you can chose one of these money-saving options:***

- **4.00/month - 12 month sub: \$48.00**
- **3.50/month - 24 month sub: \$84.00**
- **2.50/month - 36 month sub: \$90.00**

## MRH – made for sharing

One of the best ways you can ensure your free magazine has a strong future is to share it with your fellow modelers.

We make it easy to share our content pages - just click the "ShareThis" link at the top of any page, and then email a link out or make a post to any number of popular social networking sites.

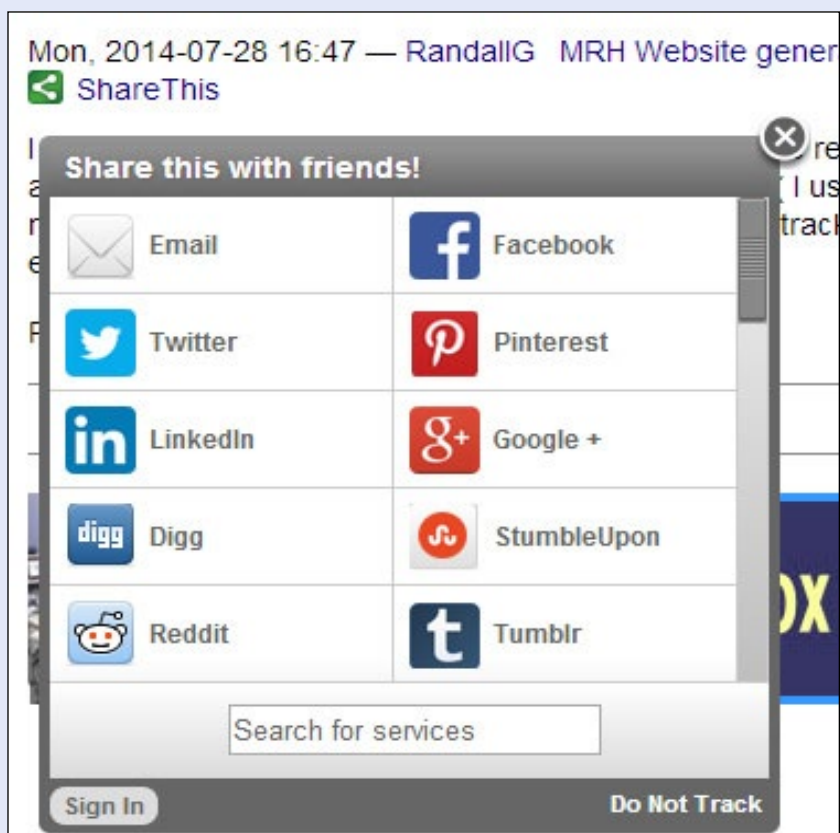

contents



index

Have you told your fellow modelers about MRH? Recently, we visited one club and many members had never heard of MRH.

We asked around and found there were a few members who *did* know about MRH – which begs the question: why had they not told their fellow modelers about us?

Shame on those modelers who knew about MRH and had not told their friends about us! Once those other modelers found out about MRH, they were somewhat dismayed the existence of MRH had been such a well kept secret among those rather closed-mouth club members.

Don't just assume everyone knows about MRH. Per our current audience size numbers, we estimate somewhere around 50% of the model railroaders out there *still don't know about MRH*.

Don't be bashful, get the word out! The more we grow, the more ad revenue we generate. And of course, the more revenue we

*Advertisement*



**1<sup>st</sup> choice for model railway supplies and service.**

**Expedited mail service available across North America.**

Click to visit:  
**WWW.CVRCO.COM**  
**1 800 464 1730**





generate, the more secure our future becomes. So if you like MRH and its forever free approach, it's in your own best interest to share MRH far and wide! Our **ShareThis** links are one very good way to keep getting the word out.

## Yes, MRH is indexed

Hardly a month goes by that we don't get someone sending us an email asking if MRH is indexed.

### *Short answer: Yes, MRH is indexed*

You have several choices for an index you can search. One really good index is Rod Goodwin's model railroading index. You can learn about Rod's index and how to use it to search for MRH content by reading this link:

[mrhmag.com/magazine/index/rods\\_index\\_help](http://mrhmag.com/magazine/index/rods_index_help)

Thanks to enterprising forum members like Bill Brillinger, you can also browse the MRH table-of-contents index for topics of interest.

Advertisement

**THE OSCALER RESOURCE**  
NEWS, REVIEWS, INFORMATION TO USE  
*New*  
**On Line Magazine**  
[www.oscaleresource.com](http://www.oscaleresource.com)



You can access the MRH TOC index at:

[mrhmag.com/mrh\\_toc\\_index](http://mrhmag.com/mrh_toc_index)

And finally, you can go to our website and click the MRH Search (Google) link at the top right of any website page and get a custom Google search against just the MRH website for a topic.

## Is the hobby shrinking?

Every so often, we run into people in the hobby who insist that it has to be shrinking. The view is held by some rather influential people in the hobby as well.

MRH doesn't share this view. We've done a lot of empirical studies and built some predictive models. These models say that since 2005 the hobby population should be on the upswing. If we check the number of Google searches for things like RC airplanes, model ships, RC cars, military models and model trains – almost always model trains has the largest number of searches, so says Google.

The HMA, Hobby Manufacturers Association, keeps statistics on annual industry sales, and for several years running now, they've reported the industry revenue for model trains is growing, while the revenue for things like RC models is down.

All-in-all, empirical hobby data that we can measure fits our predictive model that the hobby is currently growing.

## In this issue

MRH forum regular Gary Christensen gives you a step-by-step demonstration of how to do modern railcar “rustbucket weathering” on a Soo Line outside braced box car. As you follow along, you will see how what initially doesn't look like it's going to work turns into one very realistically weathered car.



Get the first 50 issues of  
**Model Railroad  
Hobbyist magazine™**

Save  
yourself  
endless  
hours of  
downloading

On a data DVD for \$10!

**Send me one!**

*(Sold by Model Trains Video)*

*Includes a coupon  
good for \$20 off on  
TrainMasters TV*

*Over 5000  
pages of  
how-to  
information  
on model  
railroading*



Next, Rob McLear takes you through the entire process of building up a resin housecar kit. You will find many of Rob's methods can be applied to other resin kit projects you may want to do.

Then Trevor Marshall's clever use of large scale switch stands allows him to get a very realistic method for throwing the turn-outs on his layout. We find the video that goes with this article to be a lot of fun, so don't miss watching it.

We bring you the next \$500 layout design contest winner this issue, our 2nd place winner by Robert Douglas. We also have a First Look of an N-scale SP&S Alco RS-3, a very nice little loco.

You may have been hearing about 3D modeling – in this issue Earl Hackett shows how you can begin exploring this amazing new technology by designing and making some simple detail parts for your layout.

This leaves our regular columns in this issue. Bruce Petrarca leads out with a lot of great tips on how to install HO DCC sound in your locos. Next, Mike Rose shows some great tips and tricks he's learned for improving the productivity of your layout building efforts.

Larry Smith is back and finishes building the coal tibble he started in his last column, and Ken Patterson shows step-by-step how he built a diorama for a signal tower switch scene and then took photo-stack photos of it.

Assistant editor Don Hanley shares with us what it was like for him to attend his first National NMRA Convention, and Publisher Joe Fugate argues the case against ever more detailed rolling stock in this issue's contrary viewpoint commentary, Reverse Running.

Enjoy the August MRH!

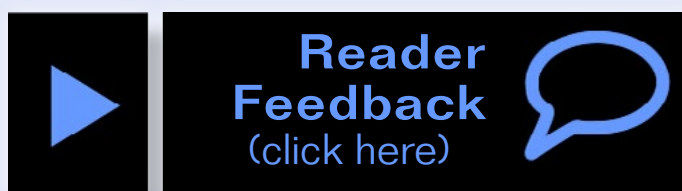

## Combo Right Clamp™

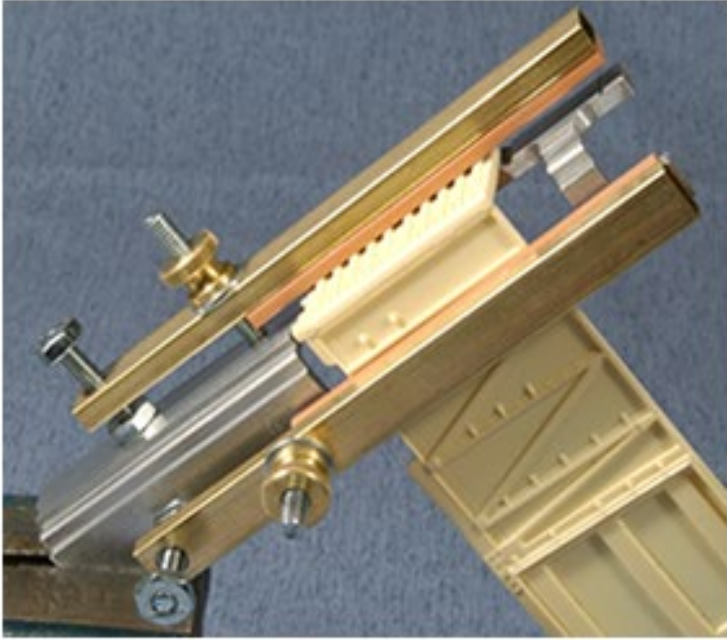

Combo Right Clamp™  
with cast resin boxcar

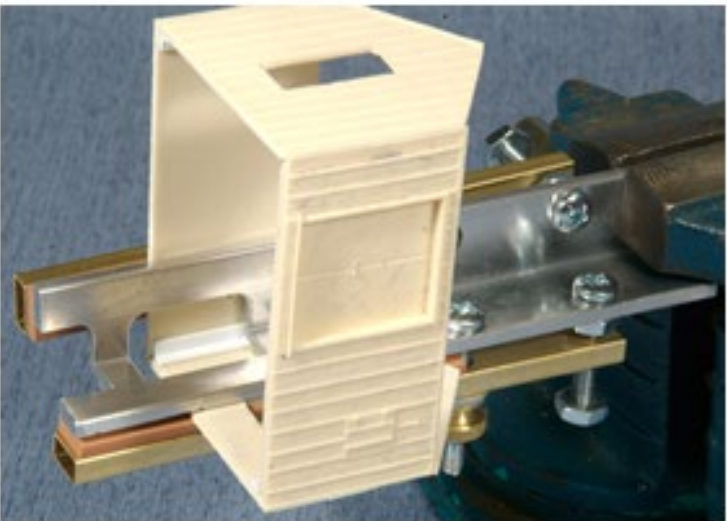

Combo Right Clamp™  
with Wolf Design Pump House

[Click here for  
all our products ...](#)

**Tools for Modelers**

Coffman Graphic Solutions Co.  
1500 River Circle, Richmond,  
KY 40475-7907

Remember  
You can click  
on the Email  
or Phone  
buttons (with  
a smartphone)  
to contact a  
sponsoring  
advertiser!

Also tell them  
“Thanks for  
sponsoring  
MRH!”



# MRRH

## Questions, Answers and Tips

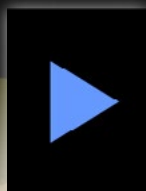

**Reader  
Feedback**  
(click here)



### QUESTIONS AND ANSWERS

#### How to remove molded-on details?

**Q.** I have a couple of Roundhouse box cab shells that I plan to put on Bachmann 44-tonner frames. How do I go about neatly removing the molded-on ladders to replace them with individual 18" Tichy drop grab irons? I have some ancient freight cars to practice on.

– Irish Rover

**A.** Deemiorgos and Dave Branum rely on X-Acto knife blades to carve away unwanted details.

"I only have experience with carving off molded-on details on Accurail cars," Deemiorgos explained. "The plastic they use carves off easily and nicely. I use an X-Acto blade, but avoid using one with an angled point."

“Get a narrow chisel blade for those areas where a regular blade won’t fit. Be sure to not cut too deep and make a gouge in the car body,” said Dave. “Once I’ve cut most of the detail off, I switch to a single-edged razor blade and scrape the rest off flush. Practice scraping with the razor blade held almost perpendicular to the car body.”

Rob Spangler favors curved blades: “They lack hard edges adjacent to the part of the blade that touches the surface, so you’re less likely to gouge it. X-Acto #10, 12, 22 and 25 are examples. I prefer the 10 and 22. Medical scalpels are great for this kind of work. Some have very small blades that can reach into tight areas.”

Ajkochev added: “One thing I’ve done in the past is wrap masking tape around the various blades, leaving only a small part of the blade exposed, to help me not nick anything I don’t want to come off.”

### Advertisement



The advertisement features a dark blue background with a white border. In the top left corner is the GLX logo, which consists of the letters 'GLX' in a stylized font inside a white-bordered blue shape. To the right of the logo, the text 'TOP QUALITY PRODUCTS' is written in a large, white, sans-serif font, with 'FOR THE MODEL RAILROAD CRAFTSMAN' in a smaller font below it. On the left side, there is a photograph of a red brick model building with a sign that reads 'BEACONER FOOD STORE'. To the right of the photograph, the words 'Cameron Block' are written in a large, white, serif font. Below this, there is a blue button with the text 'Click to Order' in white, and a white mouse cursor arrow pointing at the bottom right corner of the button. At the bottom of the advertisement, the website address 'WWW.GLXSCALEMODELS.COM' is written in white.





## 1. The 4mm Micro-Mark #80893, complete with advice for use.

Several readers, including Choo Chuck, Brent, and OKGraeme, report success with Micro-Mark “plastic modeler’s chisels.” The 4mm one is part #80893 and the 2mm one is part number 82709. Each lists for \$20.55.

“Just make sure you use it the right way around [1]. It seems counter-intuitive, but you use it with the ground side down. That way, if you slip it goes up and away from the surface rather than digging into it,” Brent explained.

OKGraeme also uses sprue cutters. “I trim off most of the mass first with #11 blades, then finish with the sprue cutters ... I use the B&B Hobby Supplies sprue cutters available through Intermountain.” See [intermountain-railway.com/bandb.htm](http://intermountain-railway.com/bandb.htm).

No matter which tool is used, a dull tool can be dangerous.





WE ONLY SELL WHAT WE MANUFACTURE

**DETAILS** IN HO, O, S & N SCALES

LASER CUT SHINGLES, DOORS & WINDOWS, FENCES, SIDING, CRATES. Also RESIN and WHITE METAL DETAILING CASTINGS.

**CRAFTSMAN KITS** IN HO, O & S SCALES

CHECK IT ALL OUT AT

**WWW.RUSTYSTUMPS.COM**

Send \$3.50 for Catalog - Specify Scale

**RUSTY STUMPS SCALE MODELS**

6785 Cherry Blossom W. Dr., Fishers IN 46038

Phone (317) 595-9489



“Being the tightwad that I am, I don’t like paying \$15+shipping for a chisel. I have had excellent results with a good old X-Acto #17 chisel blade,” said Ken Rickman. “The key to getting good results is to have it sharp! ... I lay a sheet of 600 grit wet/dry sandpaper on a flat surface, and hone the blade, back first to flatten it, then the bevel. A drop of water or light oil like kerosene helps a lot. With this technique, I’ve been using the same chisel blade for many months now, maybe years. Hand sharpening does tend to round the corners a little, which is good for preventing gouging.”

A good sharpening stone also works.

“If I needed to get into a really tight space,” Ken said, “I’d carefully grind away part of the width of the blade with a Dremel tool, or buy a narrower blade. After shaping, I’d re-sharpen the



contents



index

blade to remove any burrs that could damage the surface. Just be careful, as little sharp bits of metal flying around are not good for your health.”

“I thought this sounded familiar,” said UPWilly. “Here is the same basic question posed in 2010, 2011 and 2012. Check these out – they may have additional help.”

[mrhmag.com/node/3916](http://mrhmag.com/node/3916).

[mrhmag.com/node/6114](http://mrhmag.com/node/6114).

[mrhmag.com/node/8223](http://mrhmag.com/node/8223).

Molded on details, removing:

[mrhmag.com/node/18213](http://mrhmag.com/node/18213).

The Micro-Mark chisel tool:

[micromark.com/4mm-plastic-modelers-chisel,7584.html](http://micromark.com/4mm-plastic-modelers-chisel,7584.html).

– MRH

## Prototype movements

**Q. Is it prototypical to push seven to 10 cars from industry sidings back to a yard, over about seven prototypical miles?**

– Bob Y.

**A.** Here’s the scenario: Three industries to switch, with one facing turnout and two trailing turnouts. A siding and a runaround are available. Time on the main line is limited. There are seven cars at these industries that need to be picked up and seven cars arriving to be spotted. The engine always seems to end up at the back of the train. An option is to run the locos down the main about 1½ scale miles and switch back to the siding to get on the front.

There are three answers here, and all are valid.

a. Leave the locomotive at the tail end of the switched-out train and push the cars back to the yard.

## A terrific prototype for a switching layout!

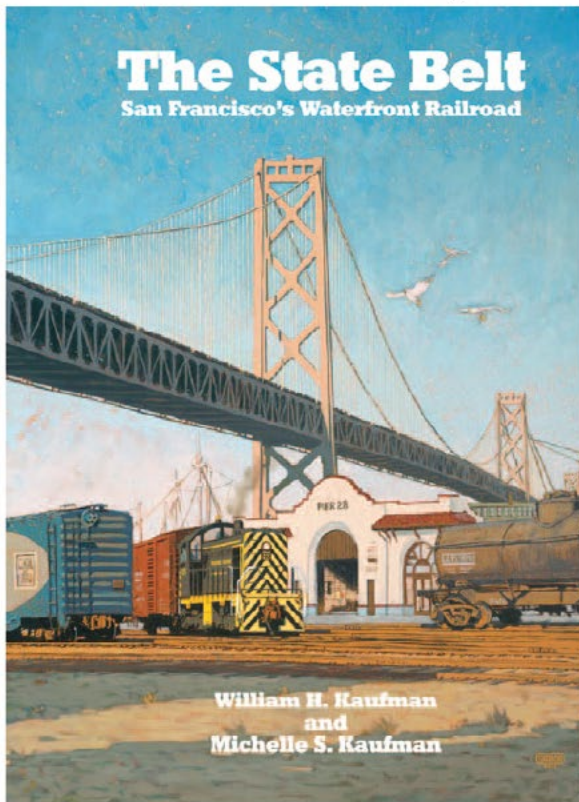

Bill Kaufman has researched the history of San Francisco's waterfront railroad, the State Belt, and presents a rich collection of industrial information and photos. How can I learn more about this book? How can I buy it?

**Click here for  
the answer ...**

*SIGNATURE PRESS*



b. Run as far as you need to, get the power on the front end, and pull the cars back to the yard.

c. Rearrange the train before it reaches the switching area, to put the locomotive on the yard end, giving a shorter 1½ mile shove to the industries.

Here's what our commenters say:

“If there is a runaround track, they would rather run the loco backwards and pull the cars.”

– Bremner

“I would run the 1½ miles to finish switching so that my locomotive would be on the front of the train on the return trip. This would provide visibility for the return trip as you would



contents



index

not have to stop (to flag across) at unguarded crossings.”

– Nelson Beaudry

“I have seen the Commonwealth Railroad here in Suffolk VA push more than 10 cars quite a long way.”

– Bob Langer

“I watch the shortline railroad here a fair amount! Cars are brought into the interchange track by NS, then the shortline railroad picks up (and yards) the cars ... Pulling the train, they head south dropping off any cars that need delivered or picked up from a siding going in that direction!

“When they reach the end of the line they do a runaround move and at this point they do push their train about a half-mile into a (runaround) siding at the end of the line. Then they head back north following the same procedure. Halfway through the run the line splits heading yet in another direction.

“Here they perform another runaround move in order to pull their train rather than push it. They take only the cars needed to be delivered, leaving the others behind to be picked up on their return trip. At the end of this line they do yet another runaround move to pull their train back where they pick up the cars they left behind. Heading north once again they go back to their starting point, the interchange track where their day ends!

“I am sure there are examples where a train is pushed a fair distance rather than being pulled but it seems from my observation that whenever possible they choose the latter!”

– Mark Kroll

“The Rochester Southern (Rochester, NY) runs an engine at each end of one of their locals down to Pavilion, NY. There is not a runaround track available and the switch into one of the industries is a facing point move. I’ve seen the trailing engine sporting an EOT device.”

– David Napper

**Bachrus** inc  
 RUNNING ON QUALITY

CHECK  
IT OUT!

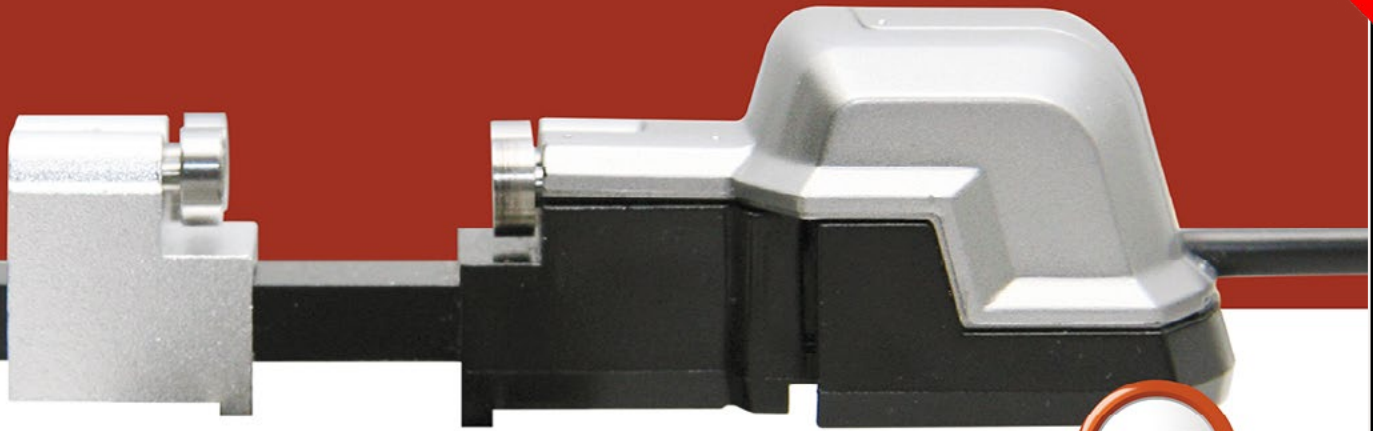

**SPEED METER**



“I know long shoves like that are avoided as often as possible, but sometimes it is just the easiest solution.

“In Glendive, MT, the regular yard switch crew is also responsible for switching out industries in the area, some of which are several miles away. Usually they have a Geep facing either direction, and they’ll split the power to get it on the other end of the train if they can, and if it is convenient.

“Most of the time, however, they drag a caboose out of the yard with them and use that as a shoving platform to get the train back to the yard when they are done. The farthest industry is about four miles from the yard, with a couple of public (road) crossings. This is all 10 mph track.”

– James Ogden



contents



index

“There’s one local here which runs about 10 miles south of the yard, and if they’re in a hurry, they’ll occasionally just shove back to the yard after switching, rather than running around the train and pulling back. In their case, shoving back makes it easier to yard the train as well, since pulling in involves running around a wye and then shoving the train into the yard.

“However, that job always takes a caboose along. They used to keep two, and ran one on each end of the train so that they wouldn’t have to switch the cab out when they ran around the train during the day. There is a union agreement which penalizes the railroad for requiring a crew to ride a shove longer than 2 miles without a caboose.

“Given the choice between a 7 mile shove and a 1½ mile light engine movement, most crews would take the latter – provided it doesn’t take too much time.”

– Ken Rickman



## 2. Switching action at Palmer MA on the New England Central RR.

“A couple years ago I exchanged email with a New England Central employee about how the Palmer Industrial Park (in Massachusetts) is switched. His comment about the return trip was that if the weather was nice and there was a nice car to ride back (like an empty center beam), he’d make sure the nice car was on the right end and do the shove [2] back to the yard rather than the runaround. The distance was probably a couple miles.

“I think there are two interesting points here:

- Don’t always do the same thing.
- If you’re going to shove back, there’s one more thing to consider during switching; which car will end up on the head end.”

– Ken Rice



## TIPS

### Holding small details

For painting small detail parts, I use a piece of electronics breadboard or perf board [3] and use MicroScale Kristal Klear to mount the parts. The Kristal Klear can be easily softened with water after the parts are painted.

– Dennis Blank Jr.

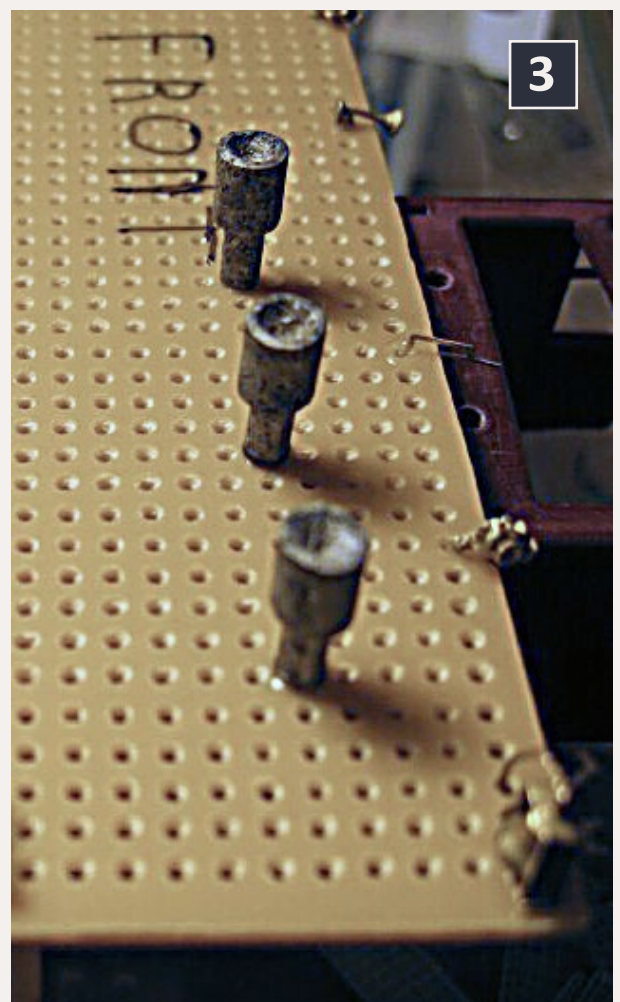

3. Glue small parts to perf board for painting.



contents



index

## Shop safety device

Have you ever returned to your workshop or layout room after several hours to discover that you forgot to unplug a soldering iron or glue gun? On a couple of occasions when this happened to me, I scolded myself for what might have been.

A simple solution is at hand [4] with components from a hardware or electrical retailer. These include a countdown wall timer (counts down to “off”), an electrical device box (steel or PVC), a cord with a three-prong grounded plug, a strain relief

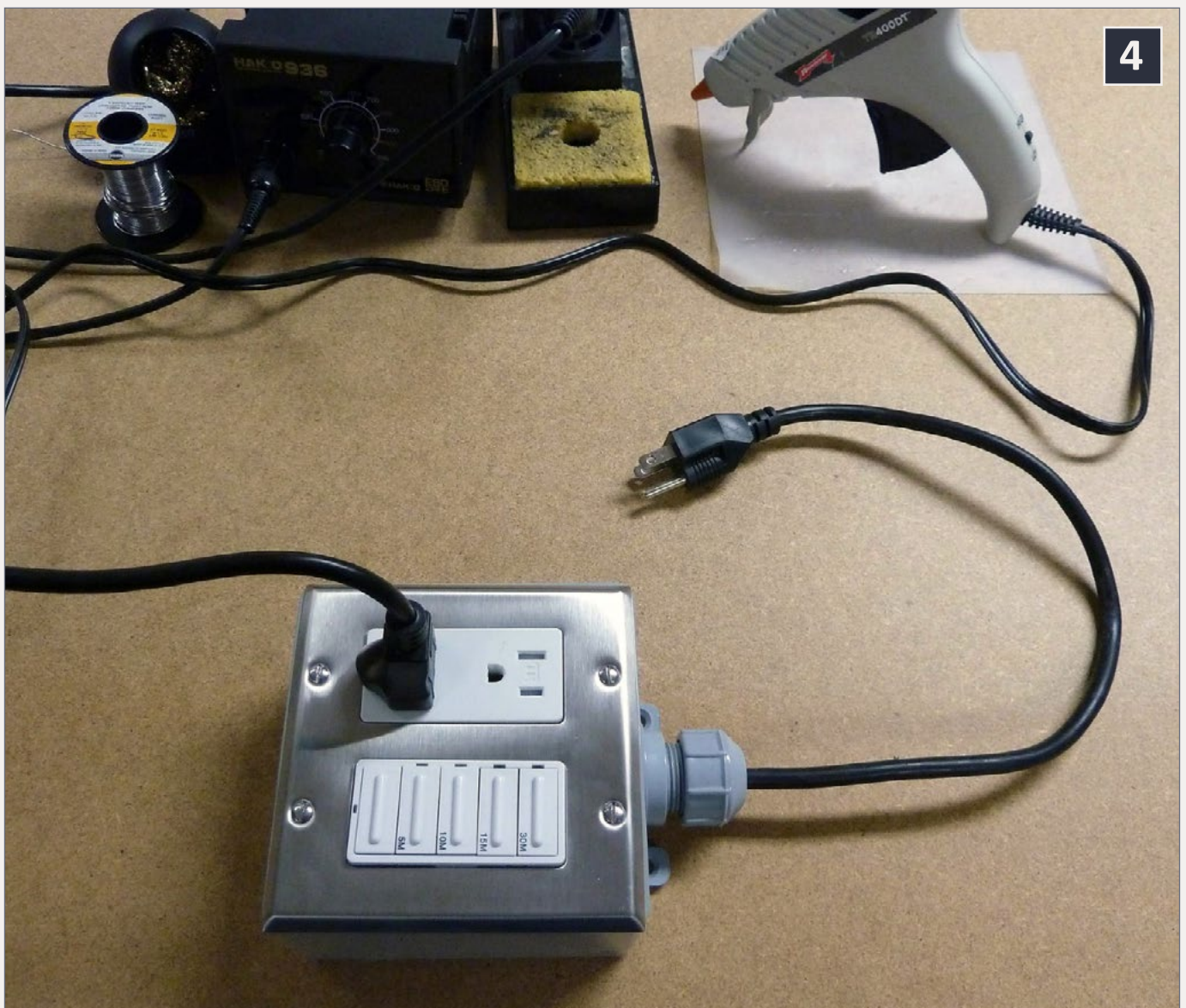

**4. A home-made “memory compensator” shuts off power to forgotten soldering irons and glue guns.**



connector for where the cord enters the box, and a typical wall outlet with double cover plate to suit the shape of the timer and wall outlet.

Wiring is very basic – for those who need assistance timers come with instructions for wiring to a light or a bathroom fan. I chose a timer that counts down to “off” in increments of 30, 15, 10 and 5 minutes, but other configurations are available. Simply plug the tools into the device outlet, plug the device into a grounded wall outlet, and set the timer for enough time to get the job done.

I store my soldering equipment, glue gun and “memory compensator” in the same place. It has become a habit to use this device whenever I solder or hot glue. I am now so conscious about shutting things off that I usually cancel the timer manually when finished. However, if I do forget, the timer will shut off the hot tool.

– Rupert James

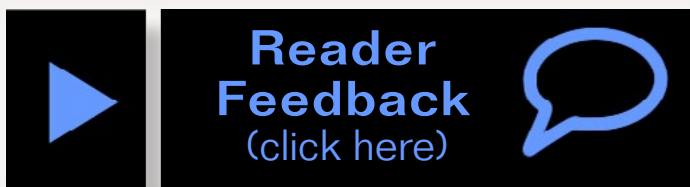

## GET \$25 PER TIP

We pay \$25 USD for each tip we publish.

[Send your modeling tips to Model Railroad Hobbyist](#) and we'll get payment to you upon acceptance.

Just think, for only a few minutes effort, you could fund your next piece of rolling stock – or even pay for an entire train if you send in several tips and we publish them!

If you include any photos with your tip, we pay a bonus of \$10 per photo we use with the tip. ■



contents



index



# Digitrax No Worries Warranty

That's it! A simple, straightforward warranty with no tricky language



You're protected against

Learn

Need tech support?

[www.digitrax.com/contact](http://www.digitrax.com/contact)

Need a repair?

[www.digitrax.com](http://www.digitrax.com)



**NO WORRIES  
WARRANTY**

**Keeps Your Layout Running!**

**For one year  
and more!**

**Protects against defects and accidental damage.**

Learn more at: [www.digitrax.com/noworries](http://www.digitrax.com/noworries)

[www.digitrax.com/repair](http://www.digitrax.com/repair)

**Need a throttle conversion?**

[www.digitrax.com/upgrade](http://www.digitrax.com/upgrade)





# Southern Digital

*Specializing in DCC Since 1992*



**20% Discount  
on most items!**



## DCC Conversions & Service

Orders Received by 3:00 pm EST ship the same day

**WWW.SODIGI.COM**

E-mail: [sales@sodigi.com](mailto:sales@sodigi.com)

(770) 929-1888

*(Photo's are from our N-Scale layout)*





# HO Sound DCC installation

DCC tips, tricks, and techniques



## DCC Impulses column

by Bruce Petrarca

*Photos and illustrations by author*

## Quick ways to install speakers in your locomotive ...

**A**s promised in my July column [mrhmag.com/2014-07-jul](http://mrhmag.com/2014-07-jul), this column will show you some methods for quickly installing speakers in your locos. My examples will be in HO, as they are the smallest-sized locos that can develop reasonable sound. They can be scaled up or down, as desired.

I use styrene for my baffles and enclosures. Just to review, an enclosure is a complete box that contains the sound coming off one side of it. See my August 2012 column [mrhmag.com/2012-08-aug](http://mrhmag.com/2012-08-aug) for more details. There are lots of other ideas (wood, metal, etc.), but I find that I get good acoustic quality with a minimum of fuss with styrene, so that's what I'll show you now.

### Caution!

There are a couple of things that are universal about speaker installation. Let's just cover them once. Understand that they are always issues. If you get any glues (styrene cement, caulk, etc.) on the speaker cone – either side – you will cause



irreparable damage to the speaker. The four holes that are designed for screw-mounting the speaker need to be plugged. This can be done by cementing bits of styrene to either side of them or running a plug of caulk down into them.

## Tools

Tools are what make this process go quickly. I was attending a clinic at a NMRA national convention when Fran Hale, MMR, was discussing tools and a technique she used. She commented something like, “Now, Miles (Hale, MMR – her husband and co-presenter) does this entirely differently. What works for me doesn’t work for him.”

The sidebar lists specialized tools I use. In Fran’s vein, you may find other tools or techniques more to your liking. But this is a place to start. Also, there are common small tools and office equipment that I won’t take the time to mention, like scissors and diagonal cutting pliers.

## Consumables

These are the products that you use, and use up. The sidebar shows what I’ve used in writing this column

## Measuring and cutting

Common to the entire process is accurate and repeatable cutting of styrene. So, first Let’s look at how to do this.

It helps if you know how to use calipers. I found a good introduction on line [tresnainstrument.com](http://tresnainstrument.com). You might spend some time there before you press on. I’ll use calipers in some unorthodox ways, but it helps to know the proper use. Using them to scribe lines on styrene, as I show, is not an approved usage. Yes, it would reduce the accuracy of measurements over time, due to wear on the points of the jaws. Just like the

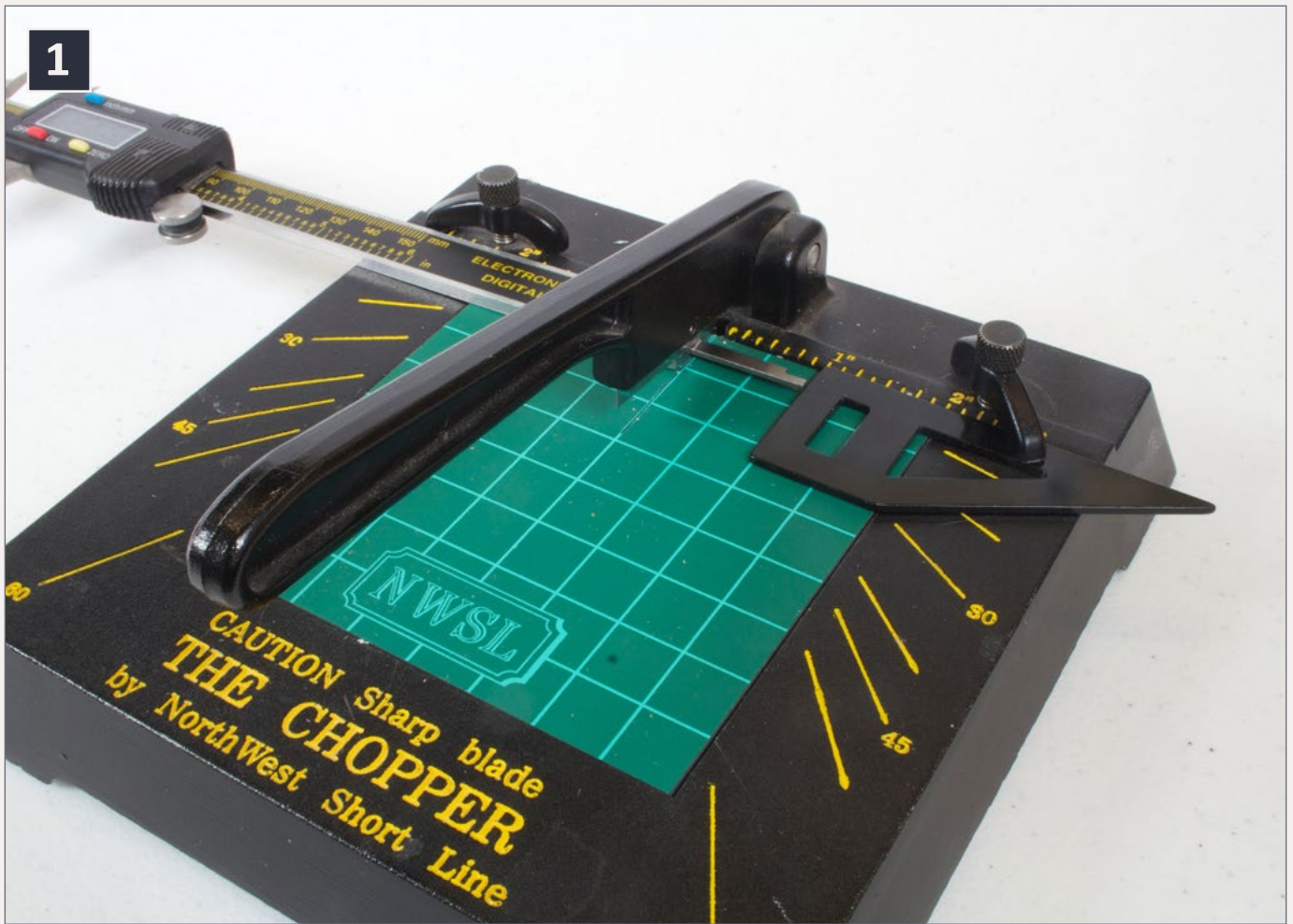

1. Transferring a dimension to the Chopper II.



Playback problems? [Click to try a different version.](#)



contents



index

paper cutter, I'd purchase a second unit only for such abuse, if necessary.

Let's say I want a piece of styrene the same size as the interior width of the loco shell. Here's my process to make a strip as wide as the loco shell. But, They say that a photo is worth 1000 words. What's a video worth, then?

Rough cut some styrene of the desired thickness to dimensions larger than the final measurements. For this example, make a 1 inch wide strip x 1 1/2 inch long (limited by the Chopper II razor blade).

Using the factory side as a reference, if possible, use the Chopper II to make a cut removing as little as possible to assure that one end is square with the factory side.

*Advertisement*

## **WOW** Did you know that...

Tsunami® Digital Sound Decoders™ include innovative features created by SoundTraxx to add fun and realism to your railroad?

We're first to feature:

- Dynamic Digital Exhaust™
- Selectable Hyperlight™ effects
- F11 braking
- 7-band Equalizer...

Just to name a few!

**Click to see what  
Tsunami can do!**

**SOUNDTRAXX®**





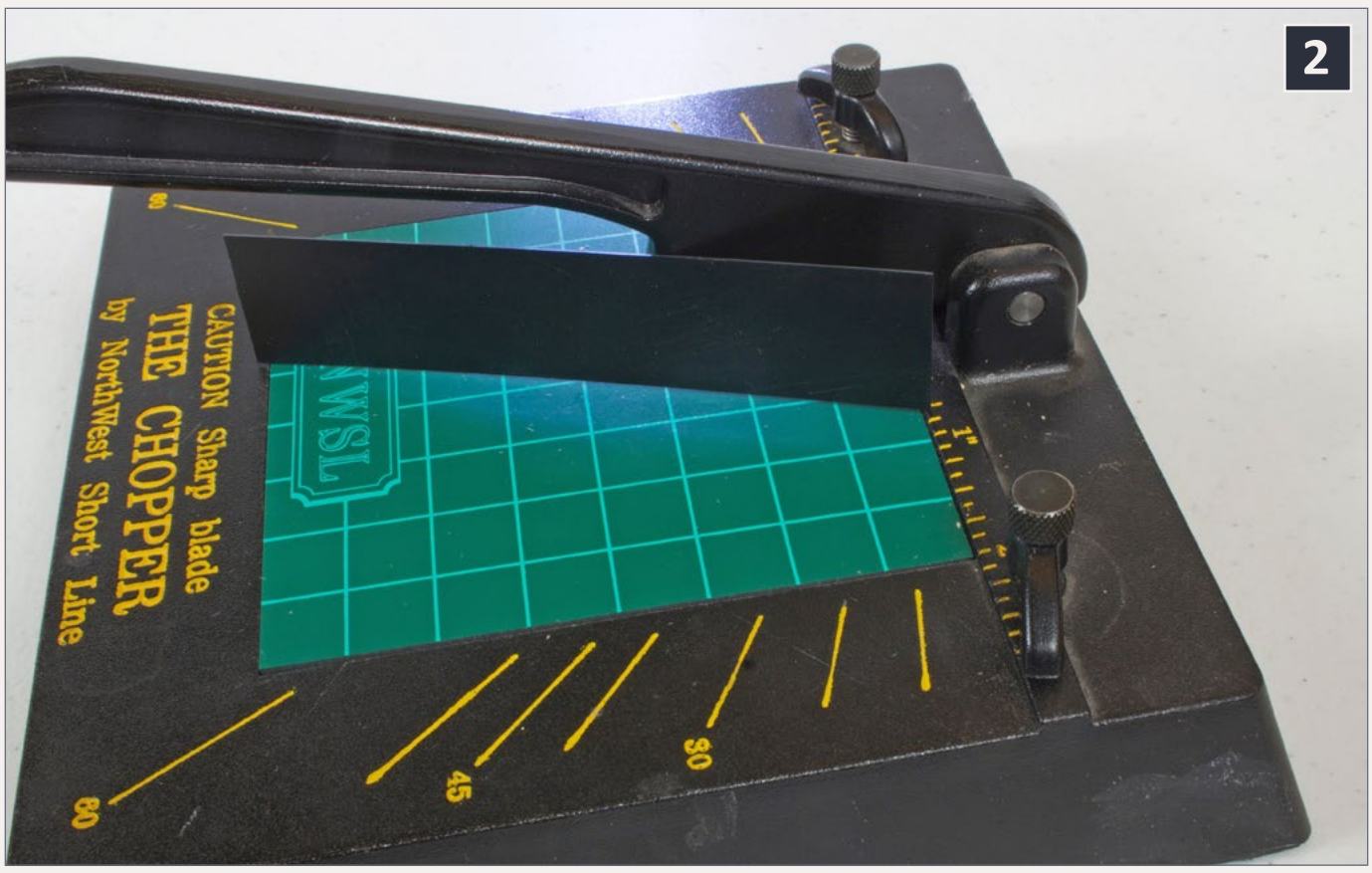

2. Testing for non-straight cut – look for light leaks between plastic and mat.

Advertisement

# END OF TRAIN DEVICE

FLASH CIRCUIT UNDER TRUCK

TRACK POWERED



READY TO RUN!



**Bright Red Flashing Light!**

Installs in minutes with no freight car modification required!

**RE RING ENGINEERING**

Patented Technology - US Patent 7,549,609

**Does not affect Load!**

↓ Car without Load ↓

↓ Car with Load ↓



For video and more click here!



Slide the strip out until the freshly cut side is lined up with the 1 1/2 inch mark and make a second cut. I now have a piece with three square sides that is as long as the blade in the Chopper II and a bit wider than my final dimension.

Use the inside measurement side of the calipers to get the width of the shell and lock them to it.

Use the extension rod portion of the calipers to adjust the spacing between the blade (be careful, it is designed to cut-very sharp) and the fence.

Cut the fourth side of the styrene strip by placing the factory side against the fence you just positioned. This strip is now square and should slip into the loco shell easily.



**3. Gasket shown with a 28 mm round speaker.**

4

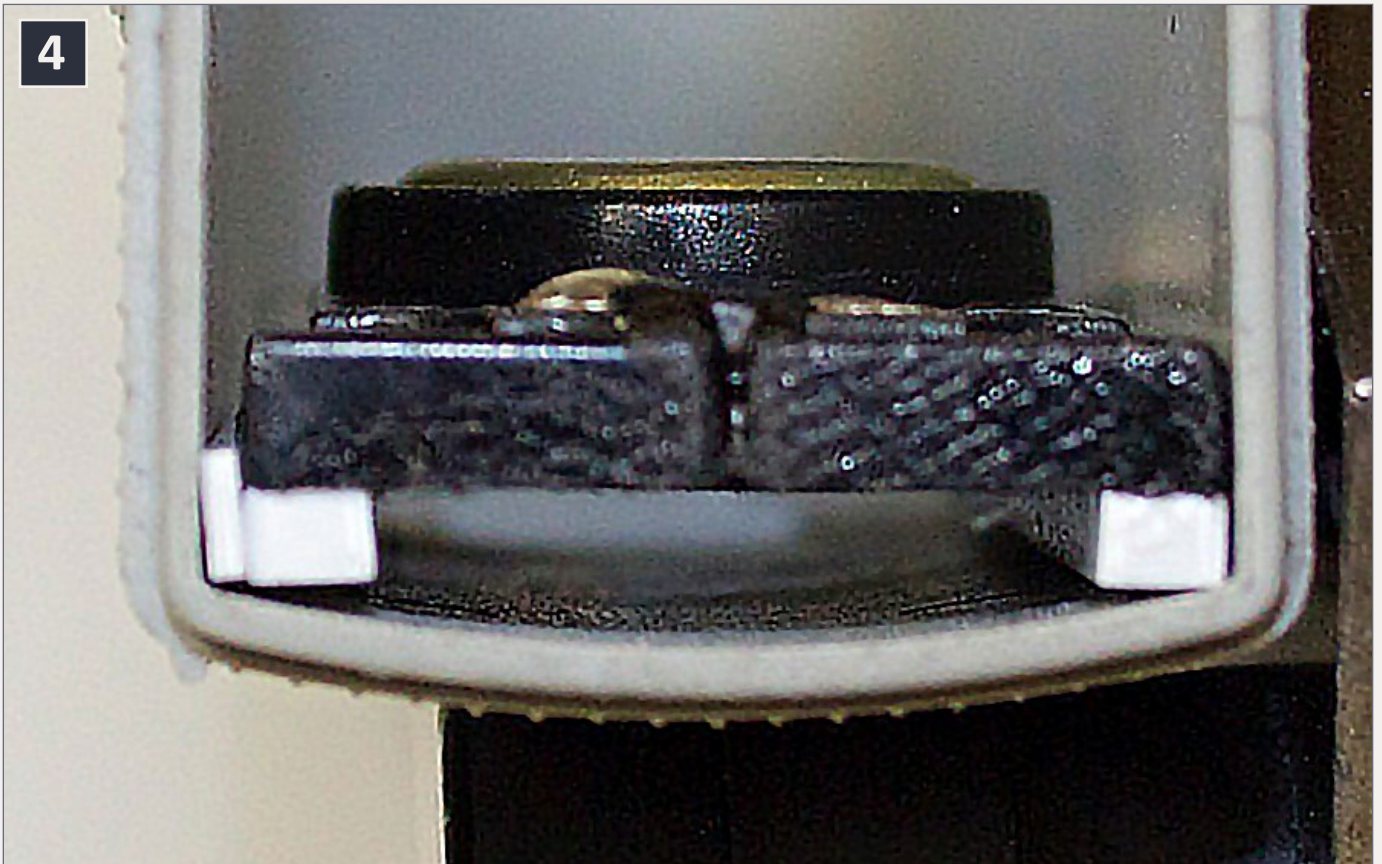

**4. Speaker assembly with white plastic spacers being tested into the shell. Look below the speaker on both sides. There's a shim on the left.**

Cut more pieces as needed now that you have the dimension set by the fence.

What if you don't have a factory-finished side to use? Put one edge of the styrene against a flat surface (like the bed of the paper cutter or the cutting mat on the Chopper II) and look at the interface [2] between the two. If they are in intimate contact all the length, that's as good as a factory edge for our needs. If not, trim a bit with the paper cutter to establish a good edge.

## **Quick installation of some speakers**

SoundTraxx sells some really slick gaskets [soundtraxx.com/access/baffles.php](https://www.soundtraxx.com/access/baffles.php) that can be used to quickly mount some



contents



index

# Get Better Sound from your Locomotives

Can't get a good sound from your sound decoder?  
Give our speakers a test drive with your ears.



**RAILMASTER HOBBIES**  
**9815 WALNUT ST #106**  
**BELLFLOWER, CA 90706**

Bass Reflex  
Speakers



High Bass  
Speakers



When it comes to speakers we have high quality speakers to fit many different applications. We are also a full line hobby shop. Need anything? We are an authorized dealer for Soundtraxx, Digitrax, Athearn, Walthers and many others. We provide quality speakers for your DCC sound systems and quality service.

**Click here for  
the *sound* answer ...**



round and oval speakers to a flat surface, like a tender floor. Of course, the speaker to be mounted must match their offerings.

These are laser-cut pieces of thin Mylar with adhesive on both sides. The installation consists of peeling the backing off one side and sticking it to the speaker. Peel the backing off the other side and then stick the speaker where you want it.

## **Shimming a speaker into a shell**

The techniques I'm now going to discuss are only ones that I've used with speakers that have a rectangular or square plastic frame.

Many of my installations revolve around having a speaker mounted in the shell. Here is how you make the speaker wide enough to fit into the shell easily. This can also be designed to keep the speaker away from those nubs of plastic that I discussed in last month's column.



**Playback problems?** [Click to try a different version.](#)

Figure [4] shows the speaker after some styrene (white) was added to it. Strips were cut the length of the speaker and glued to the cone side with MEK. These strips set the height above the shell sides for the speaker. Since the resulting assembly was .02 inch narrower than the shell, a strip of .02 inch material was cut to the length of the speaker and attached to one side.

See how it would clear the nubs? If you were building an enclosure against the top of the shell, you could choose a length of material that moved the speaker away from the top the desired amount. See the section later in this column, “Do I have enough room?”

Now that we have the speaker designed to fit where we want it, let’s go about channeling the sound where it will do the most good.

## **Creating a baffle or box against the shell**

We always try to design our speaker installations so as to get the best possible sound out. As I’ve discussed previously [mrh-mag.com/mrh-2012-08-aug/dcc\\_impulses](http://mrh-mag.com/mrh-2012-08-aug/dcc_impulses), I favor baffling to derive useful sound from both the front and rear of the speaker. However, there are times where the only feasible solution is to put the speaker in a box. Let’s look at both. Starting with the speaker we’ve set up to go in this gray shell, here’s how to baffle it or box it.

The difference between boxing this speaker against the shell and baffling the sound out an opening on the top of the shell is frequently only the distance between the speaker and the shell, as well as openings in the shell. The spacing in [4] is designed for a baffle. I’d want taller spacers below the speaker



click to play video

Playback problems? [Click to try a different version.](#)

Advertisement

Make LocoNet wiring extremely simple!

**ACCU-LITES, inc**

Your DCC Center!

“... great time saver as well as providing flexibility to change things ...” - Terry Nathan



**PM42**  
breakout  
board



**BDL168**  
Multi-zone  
breakout board



**SE8C**  
breakout  
board



**BDL168**  
Single-zone  
breakout board



<http://www.acculites.com>

**CLICK TO LEARN MORE ...**



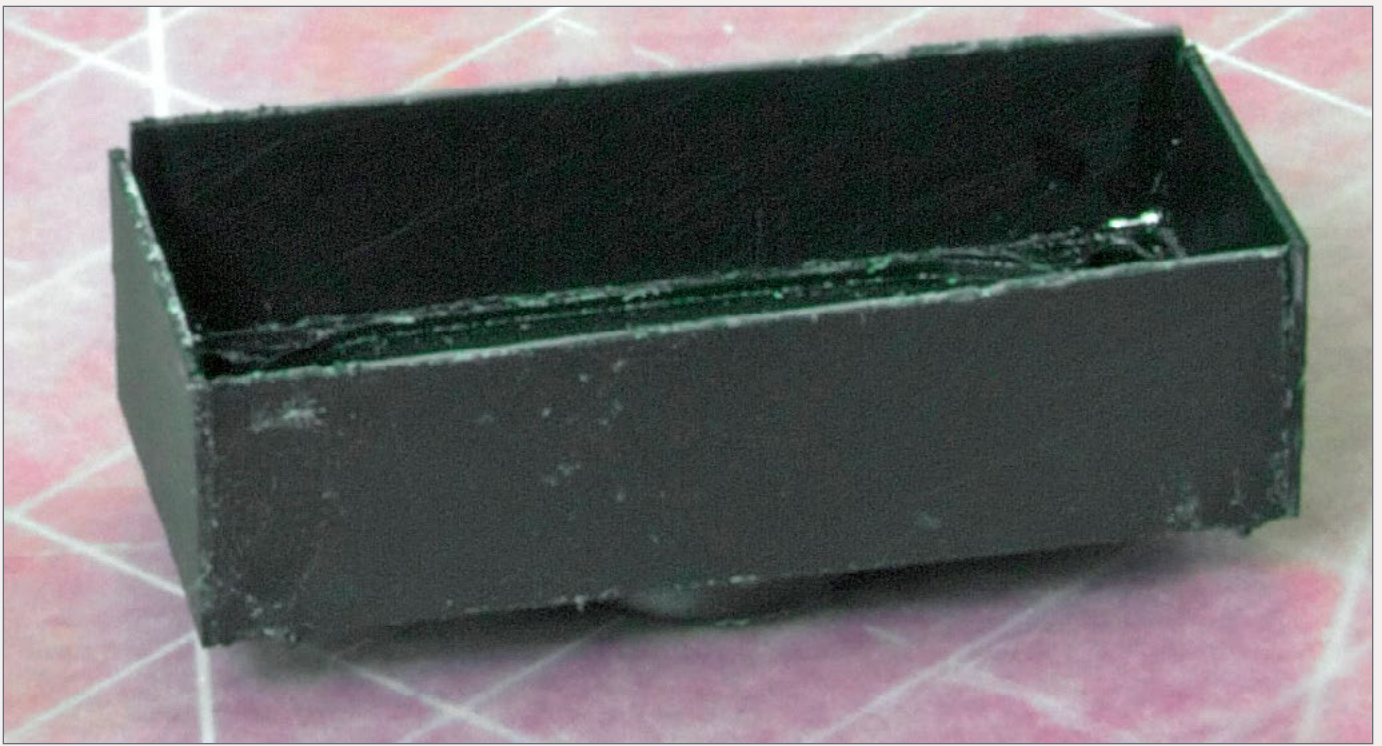

5. Speaker enclosure under construction - ready for last side to be added.

Advertisement

**IOWA SCALED  
ENGINEERING**

Put the easiest-to-use,  
most advanced fast  
clock on the market to  
work on your model  
railroad.



open source  
hardware

Master clock



Remote clock



Unlimited remote clocks  
function wirelessly!

Visit us at: [www.iascaled.com](http://www.iascaled.com)

- Any fast clock ratio from 1.0:1 to 99.9:1
- 12 or 24 hour time display formats
- Three configurable start times
- "Hold" mode for time out during an operating session

TO LEARN MORE,  
CLICK HERE





6

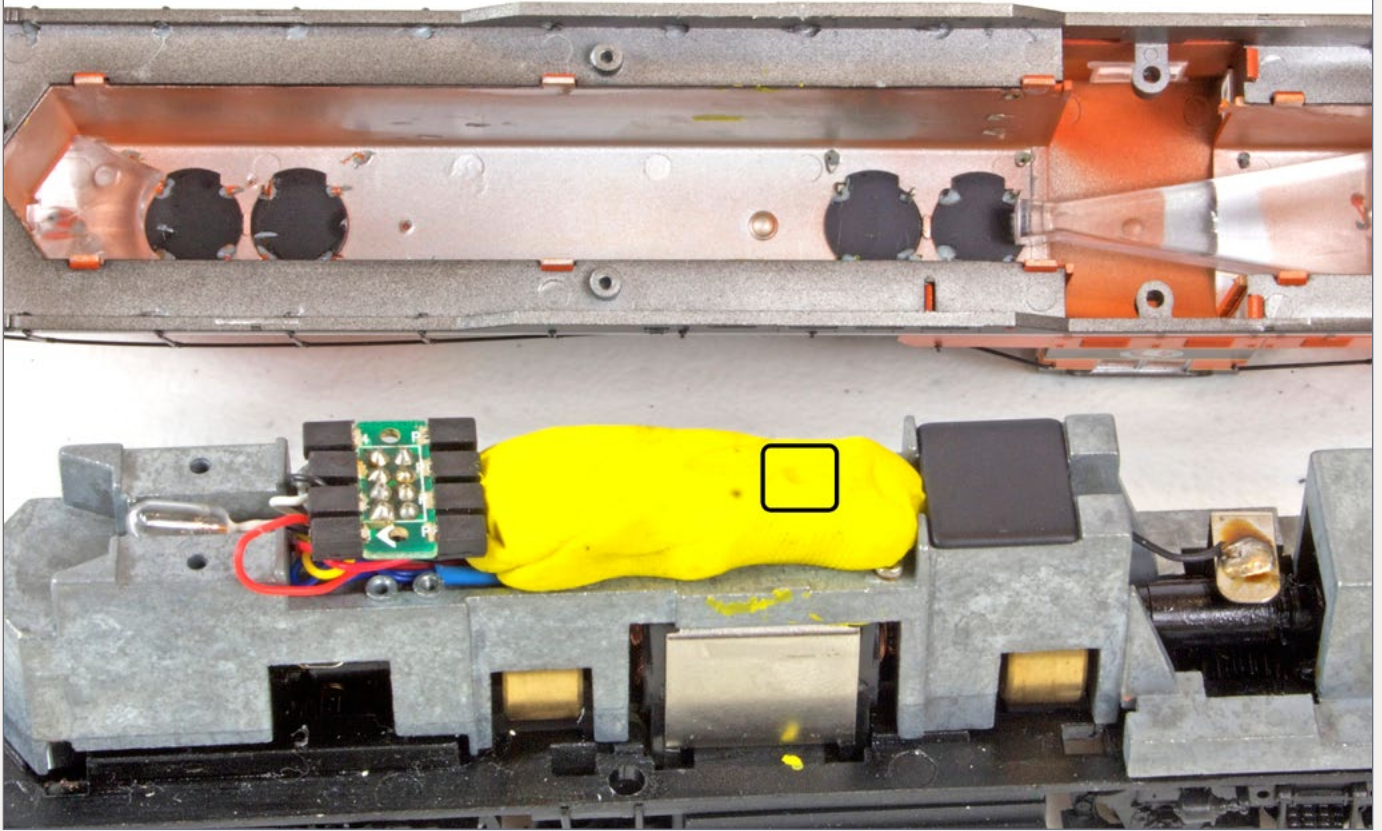

**6. The clay impression shows the room available after the shell is removed.**

for a box. I find that the larger the box, the better the sound, at least in the smaller (less than O-scale) models.

Cut two pieces of styrene -- or one if the end of the shell or some other internal piece completes one side of the baffle-and glue them to the speaker.

Hint: be sure to keep sound from coming through the mounting holes on the speaker. Then use caulk to install the assembly in the shell.

## **Mounting the speaker**

Fix the speaker in place with caulk for ease of removal, if necessary. The sonic installation would be complete with end

**RailPro™****NEW  
TECHNOLOGY****DIRECT™  
RADIO****Click Here to  
Learn More**For more information visit our Internet site: [www.RingEngineering.com](http://www.RingEngineering.com)**RE RING™  
ENGINEERING****NEW Starter Kit  
\$399.99 MSRP**

- Includes Wireless Color Touch Screen Handheld Controller and 56 Watt Power Supply
- Expandable to Virtually any Size Layout

**NEW Locomotive  
Module**

LM-2 &amp; LM-2S



- Direct Radio RF
- Sound and Non-Sound
- New Tiny Size
- 6 Light Outputs



pieces of the shell-width styrene cut to length and rounded to fit the interior roof of the shell. Either glue these end pieces with MEK to the speaker assembly before you caulk it in, or locate them with caulk after the speaker assembly is in place.

## Building a box

Sometimes I need to build an enclosure (box). This may be because I'm using a speaker that doesn't have a ready-made enclosure available, or because I need a different depth than the ready-made version. This technique results in a crude enclosure. I use ready-made if at all possible.

I use the same techniques previously discussed to cut and glue styrene to the speaker. Angle blocks keep things square while I use MEK to quickly tack the pieces together. Then I use clamps





**Playback problems?** [Click to try a different version.](#)

to hold the sides closed while I add Faller Expert cement to the corners to create a fillet and seal the box. Be sure to plug the mounting holes with styrene or caulk. Optionally, you may use some square styrene for the corners, and to cover the holes from the inside.

## **Do I have enough room?**

I can't tell you how many times I created the "perfect" installation and then couldn't get the shell back on when I was done, before I learned this trick.

When you are looking for clearance, put a wad of modeling clay in the area of concern. Then close the shell, or whatever you want to check. Open it back up and the clay will be formed into the shape of the space. Now, you can measure and plan.

In [6], you can even see the dimple from the interior of the shell reproduced in the clay -- black outline. If you know the sizes of these intrusions, so you can plan your speaker offset.



contents



index



**Playback problems? [Click to try a different version.](#)**

There you have them, some of the ways I get speaker installations done quickly.

If you found this column helpful, please click on the Reader Feedback link and rate it awesome. Please join in the conversation that invariably develops there. Until next month, I wish you green boards.



# TONY'S TRAIN XCHANGE

*Committed to your DCC support!*

## Hare™ Stationary Decoders for Tortoises™

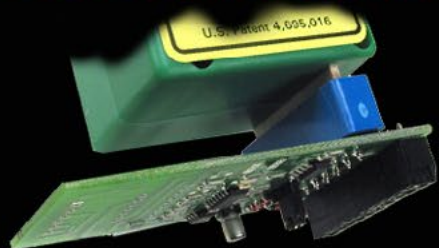

Patented Auto-Throw™ DCC & Manual Control, Makes Wiring Easy! PnP!  
Starting at \$24.95

**Order Yours**

## NCE Power Pro DCC Systems



Power Pro, Power Pro-R, Power Pro 10, Power Pro 10-R  
Starting at \$412.95

**Order Yours**

## Athearn HO Bethgon Coalporters, 5 Car Sets



**\$159.95**

Exceptional Detail, Metal Wheels, Coal Loads Included, UP/CMO, CSX, & NS

Call 1-800-978-3472 to order your Bethgons. These will sell out fast! Get yours before they're gone!

### Do you need a Sound or DCC Installation done?

**Get a quote!**



Providing unmatched person to person DCC support for more than 20 years, the kind of service that has made us #1 in DCC.

**DCC questions? CALL US! 1-800-978-3472**

\*Mention this ad for \$5.00 off your next order over \$100!

### *We'll get you on the right track!*

Aug 2014



## Sidebar – Tools

**Calipers** – I bought a pair of 6 inch metal digital calipers on sale from Harbor Freight. They have a lock, so I can hold a dimension. Plastic ones will allow you to transfer dimensions, but won't scribe styrene well and frequently don't have a lock. Vernier or dial (non-digital) calipers will work for what we are doing here, but I like the readout.



**NWSL Chopper II** – My way to make accurate cuts on styrene and wood. The razor blade limits the length of the cut to just under 1-½". The Chopper II is only a few bucks more expensive than the original Chopper and has a replaceable cutting mat. The mat makes for cleaner cuts than the Masonite on the original or the Chopper III. That's why I have a Chopper II. Change the blade frequently for the best cuts. I've even replaced the mat on mine.

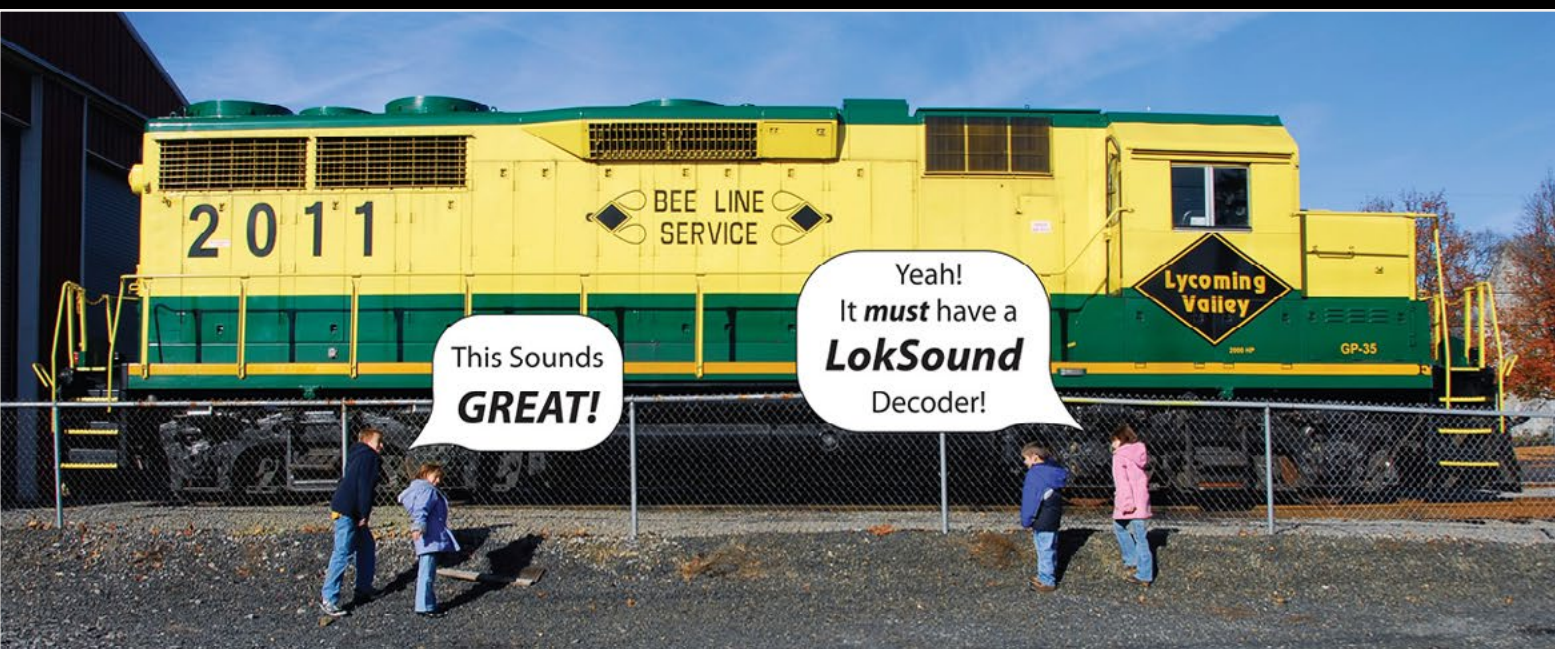

**SO REAL...You'll Think You're There!**

**LokSound Select • 3 SIZES, ENDLESS POSSIBILITIES!**

**INDUSTRY LEADING  
MOTOR CONTROL**

- Multiple Bell types
- Multiple Brake squeals

**4 OR 8 Ohm  
SPEAKERS!**

- 4 or 6 Output functions depending on the style
- Up to 4 Prime Movers or Steam Sounds on EACH decoder
- 16 Very Playable, LOUD Horns or Whistles depending on Profile
- All Changeable by using ONE CV! No Programmers or Boosters needed!\*

**Small Size  
BIG POWER! 1.1Amp!  
LokSound Select  
"4 AUX"**



**\$99.99**

**NEW 2011**

**LOKSOUND SELECT**

Only Available From ESU LLC (USA)

- Great NEW Size 1.18" x 0.61"
- Versatile DCC & DC "Dual Mode" decoder!
- 8 channel sound system!
- FOUR lighting outputs and a 1.1A motor controller
- Available with ALL Current LokSound Select Sound Profiles
- Use 4, 8, or 16 Ohm Speakers

**ONE SIZE FITS ALL!  
LokSound Select "DIRECT"**



**\$109.99**

**6 Outputs!  
LED Resistance  
Built In!**

**NEW 2011**

**LOKSOUND SELECT**

Only Available From ESU LLC (USA)

- Easy Drop in Design
- Versatile DCC & DC "Dual Mode" decoder!
- 8 channel sound system!
- SIX lighting outputs ALL with built in resistors for LEDs
- Available with ALL Current Diesel Sound Profiles
- Use 4, 8, or 16 Ohm Speakers

**Tiny Size,  
HUGE Versatility!  
LokSound Select  
"MICRO"**



**\$99.99**

**NEW 2011**

**LOKSOUND SELECT**

Only Available From ESU LLC (USA)

- Great NEW size ONLY 0.98" x .417"
- Versatile DCC & DC "Dual Mode" decoder!
- 8 channel sound system!
- FOUR lighting outputs and a .75A motor controller!
- Standard 8-pin NEM 652 plug included
- Available with ALL Current LokSound Select Sound Profiles
- Use 4, 8, or 16 Ohm Speakers!

\* ESU LokProgrammer needed to "Replace" Sound and for Firmware updates, not for normal editing

[www.LokSound.com](http://www.LokSound.com) • 477 Knopp Drive Muncy, PA • 570-649-5048

Now on facebook!



**Bypass paper cutter** – I bought a new one for the office and retired this one to the shop. One with the adjustable stop, as shown, is nice for repeating sizes. I use this to make long cuts in styrene. It isn't as precise as the Chopper, but it's quick. Frequently, I'll make a rough cut with the paper cutter and finish on the Chopper, as I show in the video.

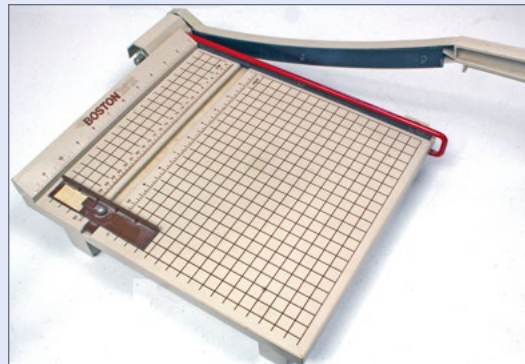

*click to play video*

**Playback problems?** [Click to try a different version.](#)

**Square** – I use a small metal square like this one to verify square cuts or to scribe lines on pieces too large to fit into the Chopper II.

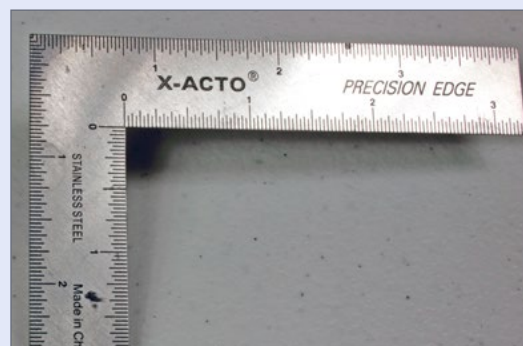



# General Electric GEVO Coming To HO



**DCC Sound Equipped With Flashing Charging Lights**



80-2344-1 G.E. Evolution E544AC Diesel Engine w/Proto-Sound 3.0 M.S.R.P. \$319.95  
80-2344-5 G.E. Evolution E544AC Diesel Engine w/Proto-Sound 3E+ (3-Rail) M.S.R.P. \$339.95

## Features

- Intricately Detailed ABS Body
- Metal Chassis
- Metal Body Side Grilles
- (2) Engineer Cab Figures
- Authentic Paint Scheme
- Metal Wheels and Axles
- RP25 Metal Wheels
- (2) Operating Kadee Compatible Remote Controlled Proto-Couplers\*\*
- Prototypical Rule 17 Lighting
- Directionally Controlled Constant voltage LED Headlights
- Lighted Cab Interior
- Illuminated Number Boards
- Flashing Charging Lights
- Powerful 5-Pole Precision Flywheel Equipped Skew-Wound Balanced Motor
- Locomotive Speed Control In Scale MPH Increments
- Operates On Code 70, 83 and 100 Track
- 1:87 Scale Proportions
- Built-In 28-Function DCC Decoder
- Proto-Sound 3.0 With The Digital Command System Featuring Freight Yard Proto-Effects
- Operates On 22" Radius Curves
- Proto-Sound 3E+ Models Operate on R2 Radius Curves (Marking C or K Track HO Stud Rail Only)

**\*\*Proto-Sound 3.0 Models Only**

M.T.H. Electric Trains is bringing the first HO GEVO diesel locomotive to market this Fall with operating charging lights\*. Outfitted with a powerful five-pole skew wound flywheel equipped motor, LED lighting, remotely operated Kadee® compatible couplers, user-installed Kadee® replacement couplers, full digital sound and a 28-function DCC decoder with Advance Consisting, Feature Mapping and Speed Mapping make this and all M.T.H. diesel locomotives HO's best motive power value.

*\*Only 80-2344-1 and 80-2344-5 have charging lights*



HO TRAINS THAT DO MORE

[www.mthHOtrains.com](http://www.mthHOtrains.com)



©2014 M.T.H. Electric Trains



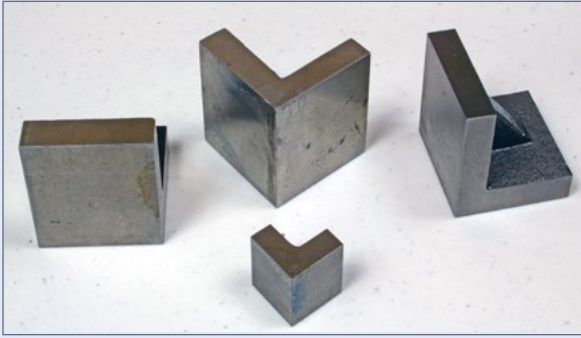

**Machinists blocks** – I use several in different sizes to keep things square while I'm gluing them together. Use a chisel blade in your hobby knife to remove any glue or foreign matter on them. If you sand them, you risk changing their exact right angle.

**Magnetic cutting mat** – I bought this at a craft store, in the scrapbooking section. I bought an assortment of magnets to use with it. The mat is not magnetic, but will attract magnets put on it. Mine came with the stainless steel ruler with a magnet attached to the rear of it.

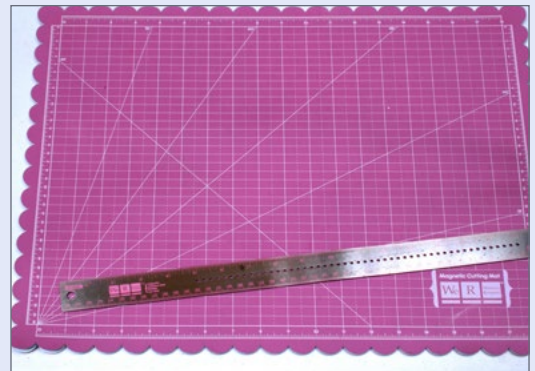

**Modeling clay**– Yes, this is a tool, not a consumable. Try a toy store, art store, or craft store. The art stores may be more expensive, but have some non-sticky versions and other versions that can be hardened into a template.

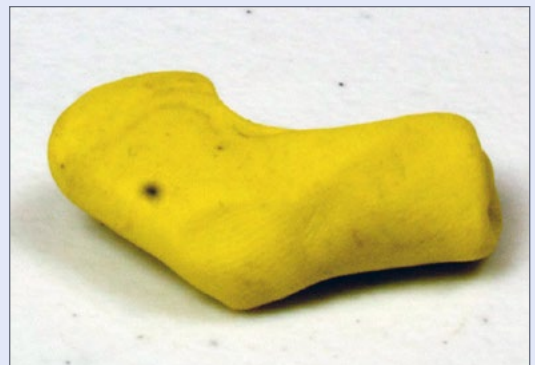



**Needle applicator** – I use this to dispense styrene solvent. I find it easier to use than a brush.

## Consumables

**Sheet styrene** – I encouraged Evergreen Scale Models to make 6” x 12” black sheets. That's all I use. It hides better inside the locomotive. Enclosures and baffles need thicker sizes like 0.060” or more. I keep some of every thickness in stock to use as shims.



**MEK (Methyl Ethyl Ketone)** – My favorite styrene cement. Get it at a paint or home improvement store in quarts for about \$10. Fill the needle applicator with it. Dries very quickly.



contents



index

**NEW!**

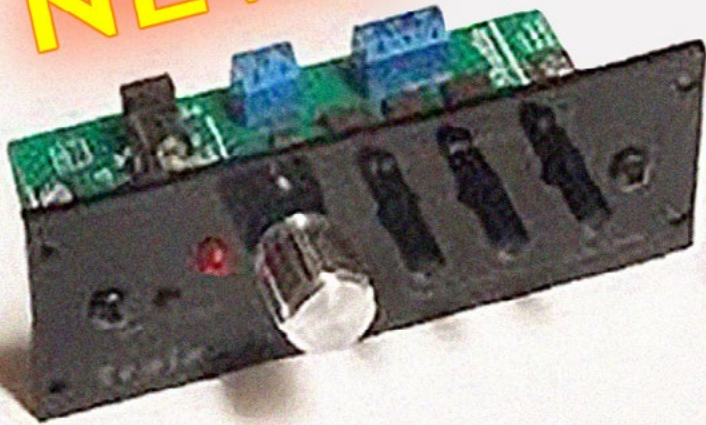

**DCC Train Shuttle ...  
aka, "Prof Silencer"**

**TamValleyDepot.com**



**RR-CirKits, Inc.**

*Affordable Electronics for Model Railroads*

- Computer Interface
- Signaling
- General I/O
- Block Detection



**WatchMan**



**Now Shipping!**

[Learn More ...](#)



**Your Local N Scale  
Online Hobby Shop**

**575-523-9743  
fiferhobby.com**



**Faller Expert (styrene cement)** – This is a typical methyl chloride type cement with a twist. It has a percentage of styrene dissolved in it. It will make fillets and fill small cracks. Applied to the cut end of clear styrene rod, it gives a lens-like finish without polishing. It is much slower than MEK to set, however. To avoid clogging the needle applicator, throw away the blue cap and plug the applicator with a piece of 0.015 beryllium copper wire.



**Bathtub caulk** – I use clear Polyseamseal in a tube, as shown. A 5.5 fluid ounce tube lasts me a year or so, so there is no reason to buy one of the big tubes. Any acrylic caulk will do. There's - no need to pay for silicone.

**Toothpicks** – I prefer the round ones. This is the drawer from my workbench organizer. I use a lot of them. I keep them in the shop. That way I don't wind up in the kitchen with something toxic on my hands, rummaging through the drawers.





**Wax paper** – Another item to buy at the grocery store. Get your own roll, so you don't have to run to the kitchen when you need it.

**Emery boards** – I buy basic ones at a dollar store. Beauty supply shops, like Sally's Beauty, offer a line of more expensive, larger units with grits ranging from 100 to 600. I have a supply of those, too. ■

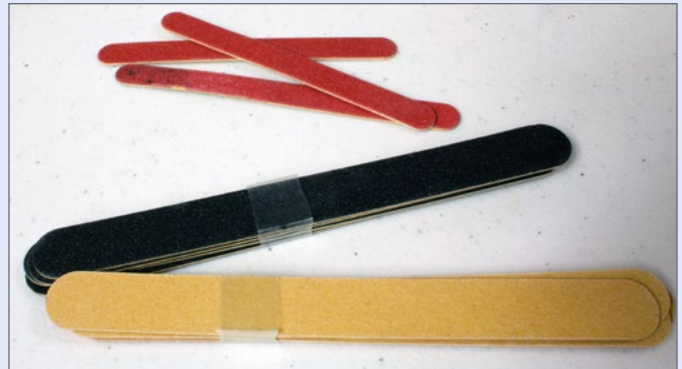

Advertisement



**Been WOWed?**

**WOWSound**

The world's leading sound decoder



**Reader Feedback**  
(click here)



Email



Phone



contents



index

**DCC  
Specialists  
Since 2001**

Check us  
out on the  
web!



**www.Mr-DCC.com**

***Glad to help those  
getting started in DCC!***



**S T A T I O N**



# NCE Switch *and the Button*

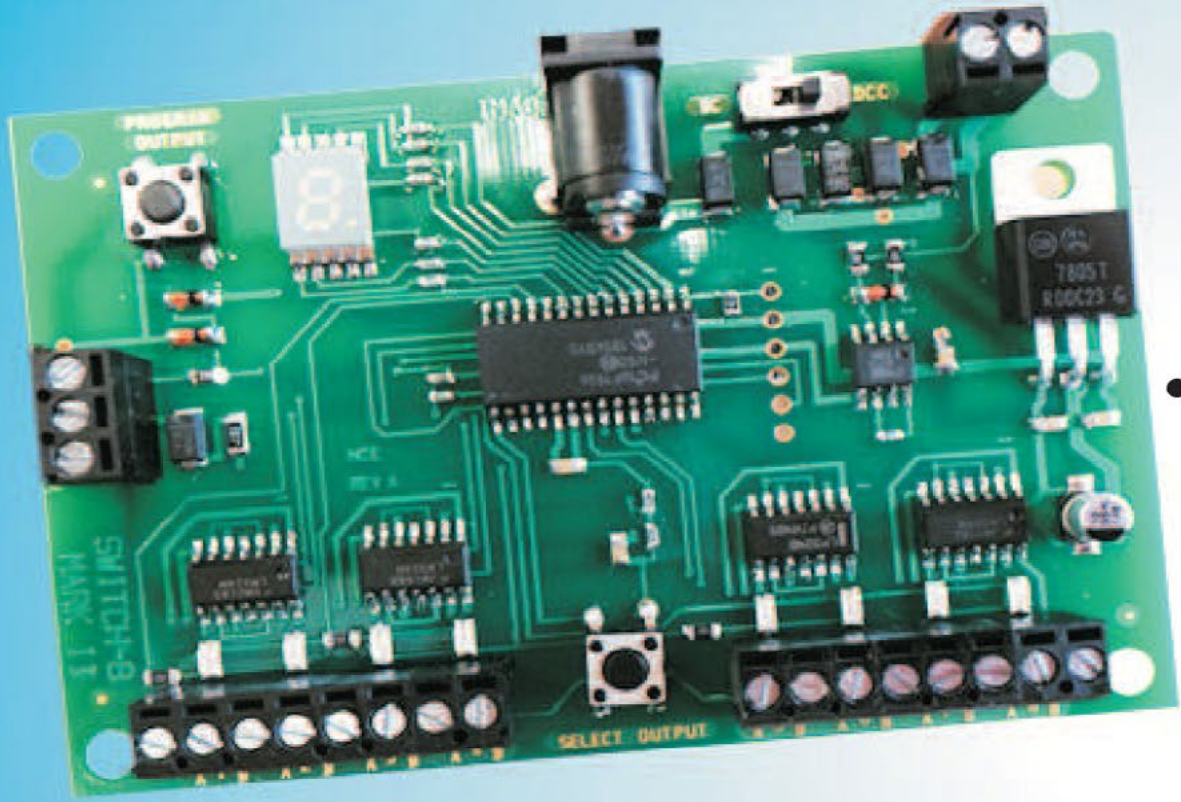

Introduct

## Sw

- Impr
  - Track p
- 524

w  
e

An

# NCE

*The Power of DCC*

Manual is

C

for F  
support@





# Switch8-Mark2 on Board

Introducing the brand new  
**Switch8-Mark2**

Easy to program  
Improved user feedback  
Power or External power  
5240151 - \$69.95 ea.

Manual is available at  
[www.ncecorporation.com/  
extras/manuals/decoders](http://www.ncecorporation.com/extras/manuals/decoders)

**Now Shipping!**

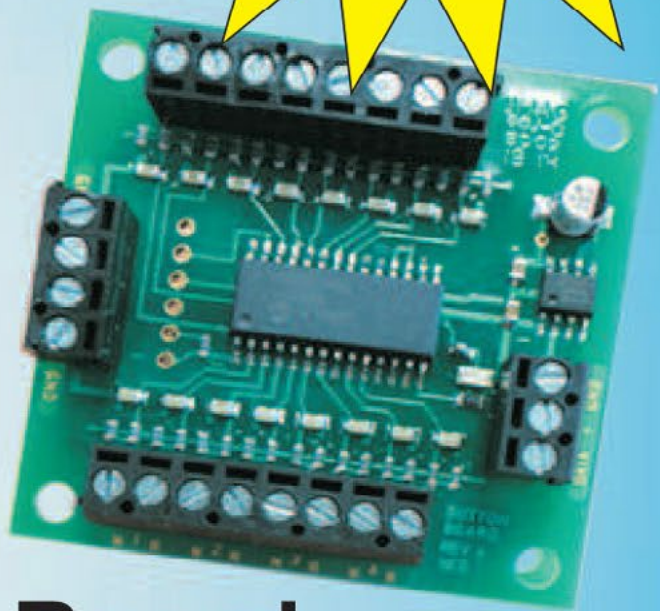

And the new **Button Board**

Add on accessory device that expands  
the operation of the Switch8-Mark2.

5240152 - \$29.95 ea.

available at [www.ncecorporation.com/extras/manuals/decoders](http://www.ncecorporation.com/extras/manuals/decoders)

## *Discover the FUN!*

• Made in the U.S.A. •

Call or Email  
FREE Brochure  
[@ncecorporation.com](mailto:info@ncecorporation.com)

585.265.0230  
9am-4pm EST.  
[www.ncedcc.com](http://www.ncedcc.com)



Due Fall 2014

# Bowser

## *EXECUTIVE LINE*

### HO ALCo Century C-636 Locomotives



Ready to Run and Detailed. 13 Roadnames.  
Available with or without LokSound Sound.  
MSRP \$199.95 With Sound \$299.95

### HO PCC Streetcars



Ready to Run and Detailed. 6 Roadnames.  
Available with or without LokSound Sound.  
MSRP \$159.95 With Sound \$259.95

Click here to check out the details for these and other great Bowser products!

[www.bowser-trains.com](http://www.bowser-trains.com)





# Layout Building Productivity Part 1

Modeling real railroads and what they do

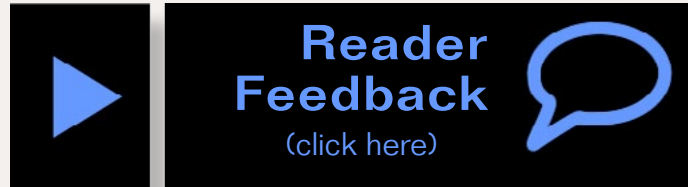

## Getting Real column

by Mike Rose

### It's not just for superhumans! ...

I go to as many Prototype Modeling meets as I can. This year so far I've attended Prototype Rails in Cocoa Beach, FL in January, the RPM Valley Forge Meet in Malvern, PA in March and the New England Proto Meet in Collinsville, CT in June. I go to lots of others, but those are the ones I almost never miss.

I was talking to one fellow before my clinic in Malvern and he mentioned that he was looking forward to meeting me in person because he assumed I was some kind of super-productive overachiever -- an impression he'd gleaned from reading my articles and listening to me talk about my layout efforts on The Scotty Mason Show podcast I do monthly. I laughed, because I know better, but it got me thinking about what it takes to actually get things done, and it also caused me to reflect on the pace of my railroad activities of late.

In my last Getting Real column (How Long Did It Take to Build Your Layout? [mrhpub.com/2013-12-dec/land/#33](http://mrhpub.com/2013-12-dec/land/#33) for Part 1, Part 2 next month), I covered a major decision and effort



to tear down the oldest sections of my layout and start from scratch. Planning, walls, track and operations were all covered, and two successful op sessions were held.

Heading into the winter after the last op session in November, I decided to make a major push to get scenery in place in a large section of the layout. I really wanted my layout back! Remember, we left things with essentially bare benchwork and track, looking at the back of scenery in the other aisle. For me, normal layout construction methods would have resulted in at least another year of work to rough all this in. What could I accomplish if I really set my mind to it, if I used some different, more modern constructions methods? I set out to find out.

## **Floral foam scenery: New to me**

Mike Confalone and I cross-pollinate in terms of layout ideas. He had been using green floral foam to create convincing scenery in record time, and persuaded me to try it out. His reasons to use it were compelling:

- It was fast to install, and easy to cut
- It could be easily carved, and the open-cell foam was much easier to carve than typical pink or blue closed cell foam used for insulation
- With the need to install hundreds and hundreds of trees, I could simply poke the trees in place rapidly instead of drilling a hole for each one as in my old plaster cloth scenery

The only downside I could see was cost, but I addressed it in part by using 50%-off coupons, readily printed from the A.C. Moore and Michael's websites, to buy it continuously in quantity with dozens of visits to the store -- and having my wife and friends do the same! – until I had a critical mass of foam to begin. And I was not shy about getting Mike C. down to help me get started, since this was a different mindset for scenery



**1. In Laceyville, I was unhappy with the track layout, the 200' cliffs behind the town, the foam chunk greenery, and the way the space was laid out.**

creation for me. I was in “additive mode” most of the time, and this was a “subtractive” methodology as you will soon see. First, a little background.

## **Laceyville**

I had made an early attempt at the town of Laceyville, but was never happy with the results, which is why it remained largely devoid of scenery until the rebuild, as shown starting above.

... Article continues on next page →



contents



index



**2. At the left side of Laceyville, a large lump intruded into the scene. Yes, there was a coal mine on the other side, but I soon realized that most of this lump could go away and allow me much more room not only for Laceyville, but perhaps also the nearby town of Wyalusing.**



**3. This aerial shot, taken from the end of the peninsula in the duck-under where the cross-aisle bridge is during sessions, clearly shows how the mountain was used to divide the peninsula. At the top center-right you'll just make out the mine on the opposite side of the left hand lump.**



contents



index

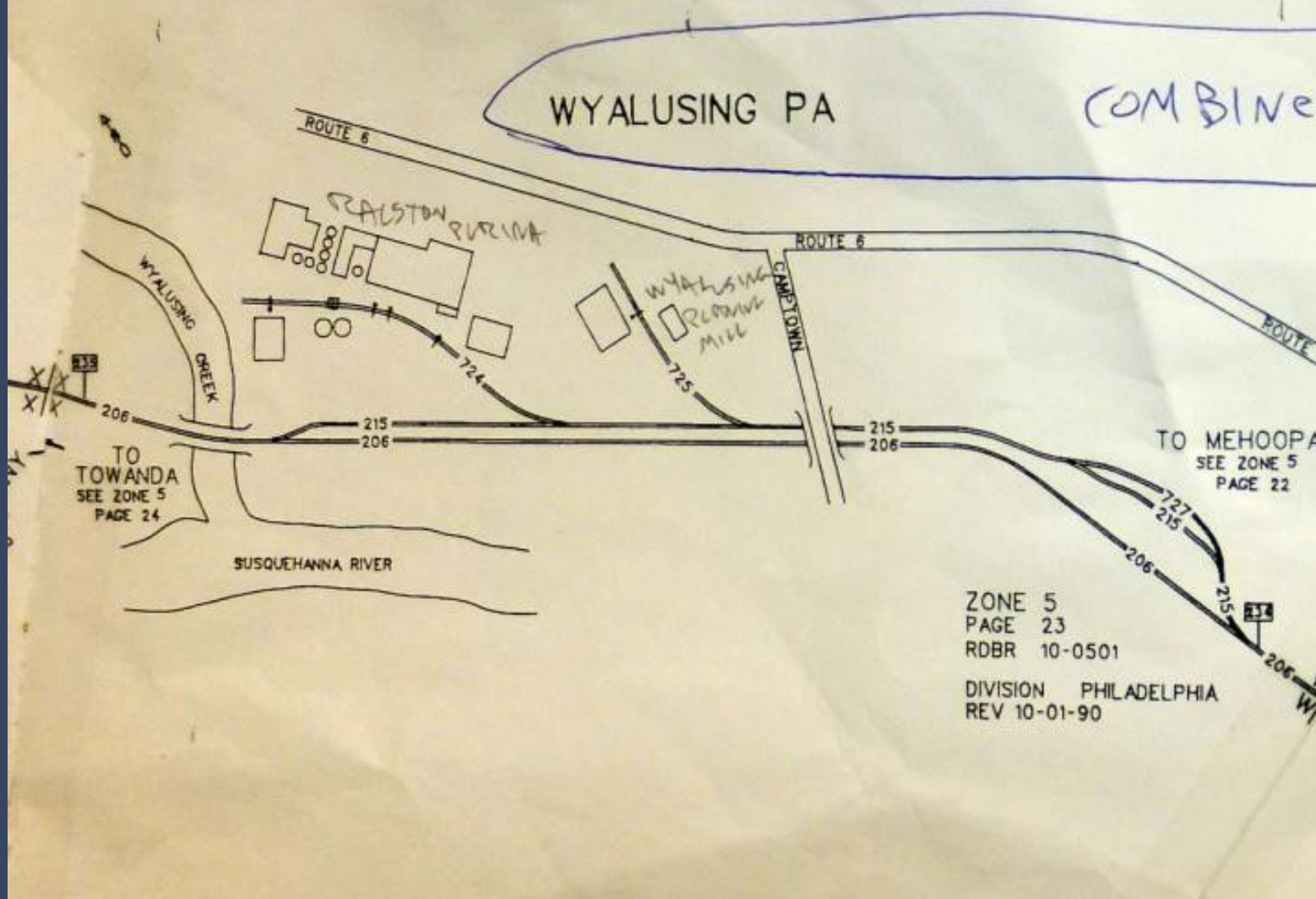

4. I was mulling the Laceyville track arrangement one evening with friends Dave Santos and Jim Lincoln when Jim pointed his chin at the above prototype map (Conrail Zone Track Spot or ZTS map) and postulated “Why don’t you just recreate the prototype track arrangement just like it is?” Yeah ... seems kind of obvious in retrospect, and that’s just what I ended up doing!



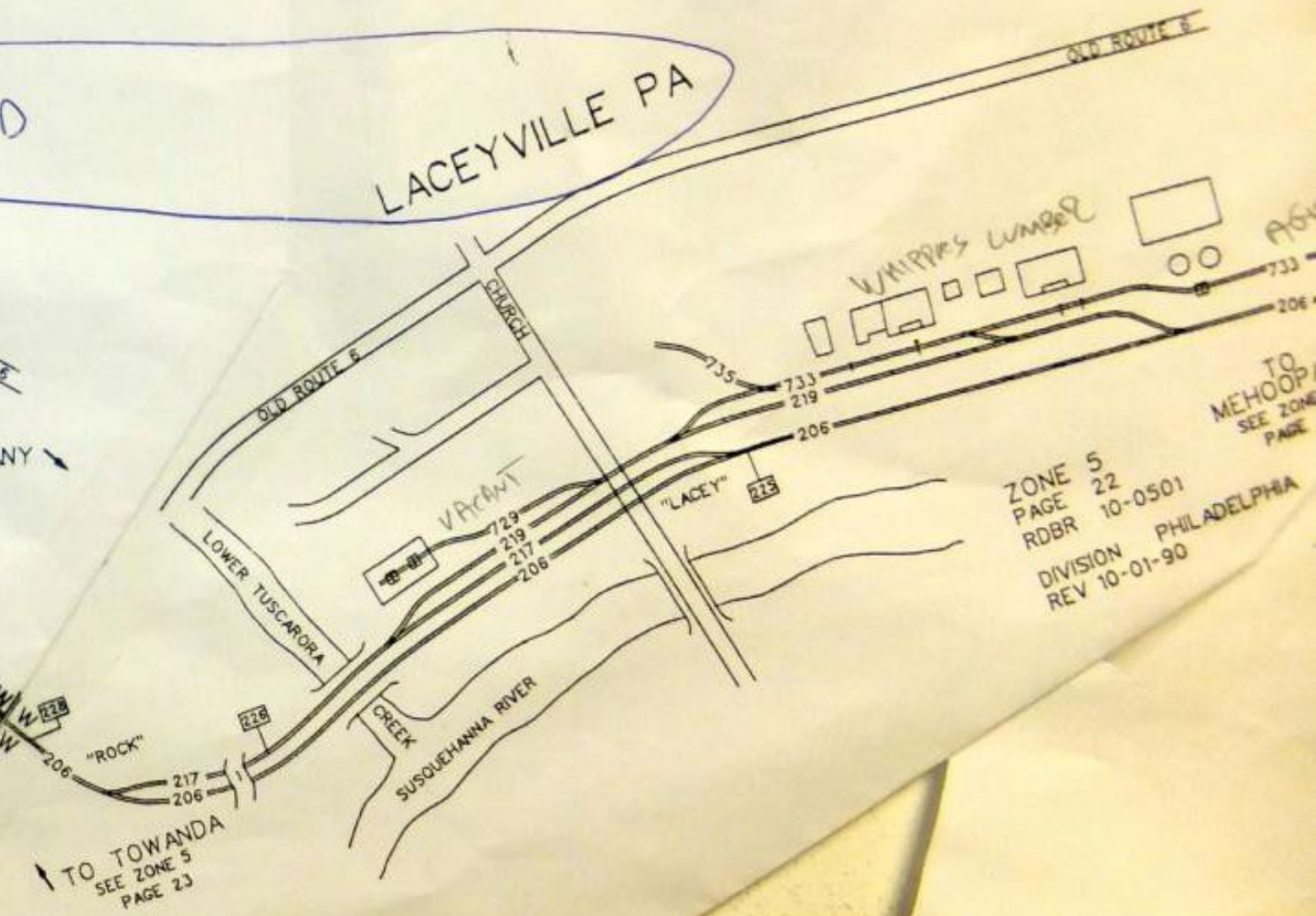

ZONE 5  
 PAGE 22  
 RDBR 10-0501  
 DIVISION PHILADELPHIA  
 REV 10-01-90



5. With the new track arrangement in place, it was time to start constructing scenery. The lump between Laceyville and the end of the aisle is now removed, and some 2" pink foam board was laid down on the benchwork to act as a foundation for the more expensive green floral foam.

### Advertisement

"O" Scale Standard Gauge



\$89.95 each

San Juan Car Co. 190 Turner Drive Unit C, Durango, CO 81303

(970) 385-5256 Fax: (970) 385-1030

sanjuancar@durango.net • www.sanjuancarco.com



Email



Phone

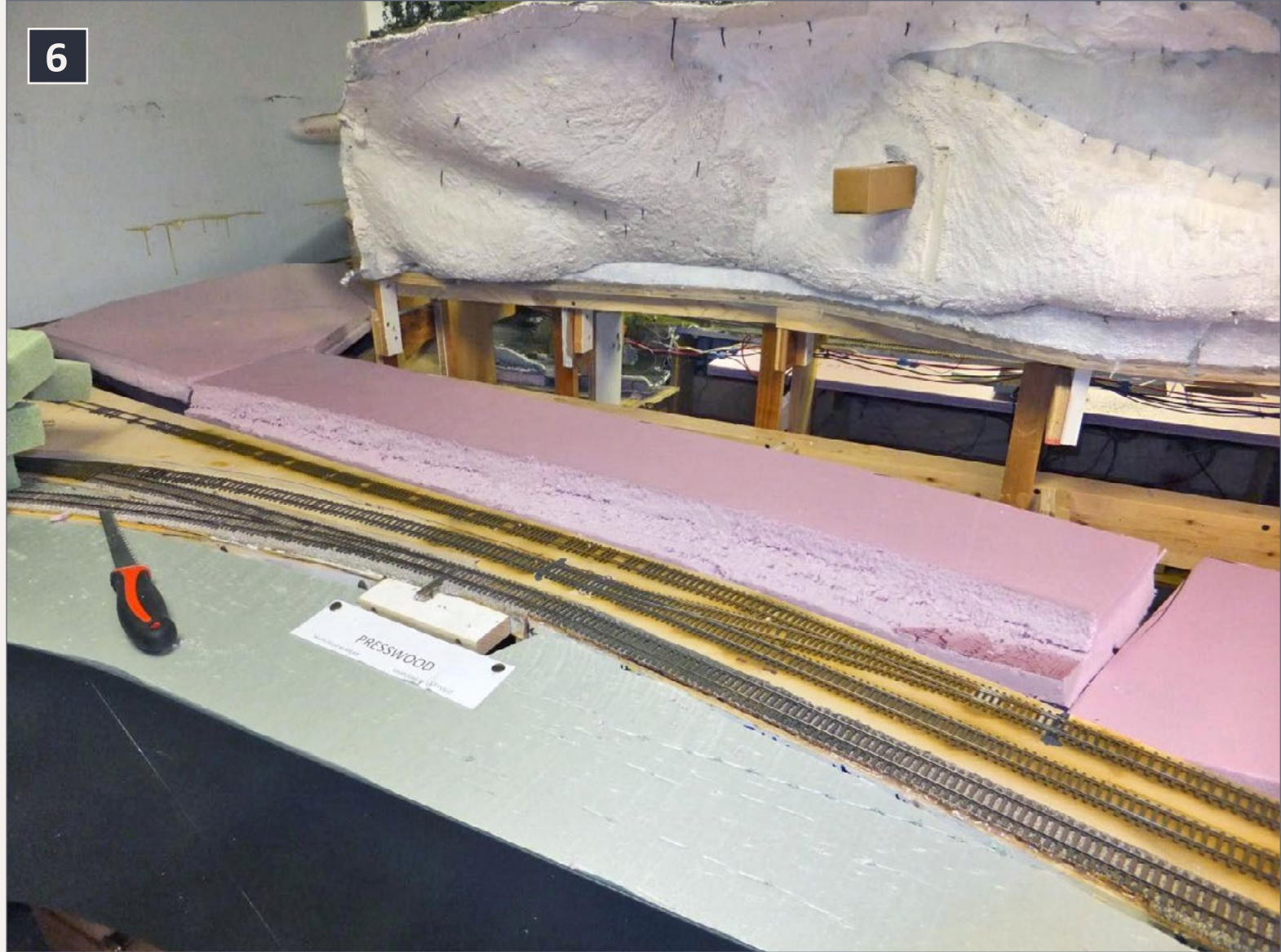

Advertisement



**Archer**  
FINE TRANSFERS™  
PROUDLY SERVING MODEL BUILDERS SINCE 1989

**THE ORIGINAL  
SURFACE DETAILS**

PRECISE SCALE RESIN RIVETS,  
LOUVERS, TREADPLATE, WELD BEADS  
AND MORE ON CLEAR DECAL FILM

**CLICK HERE TO WATCH  
VIDEO TUTORIAL**

**CLICK HERE TO SEE  
THE RESULTS**

**CLICK HERE TO BROWSE  
AND BUY**

Archer Fine Transfers • PO Box 1277 • Youngsville, NC 27596 • USA  
(919) 570-1026 • info@archertransfers.com • archertransfers.com

6. In another view of the pink foam foundation, I carved away some foam to make room for an access road along the tracks. To the left is the future town of Wyalusing.



contents



index

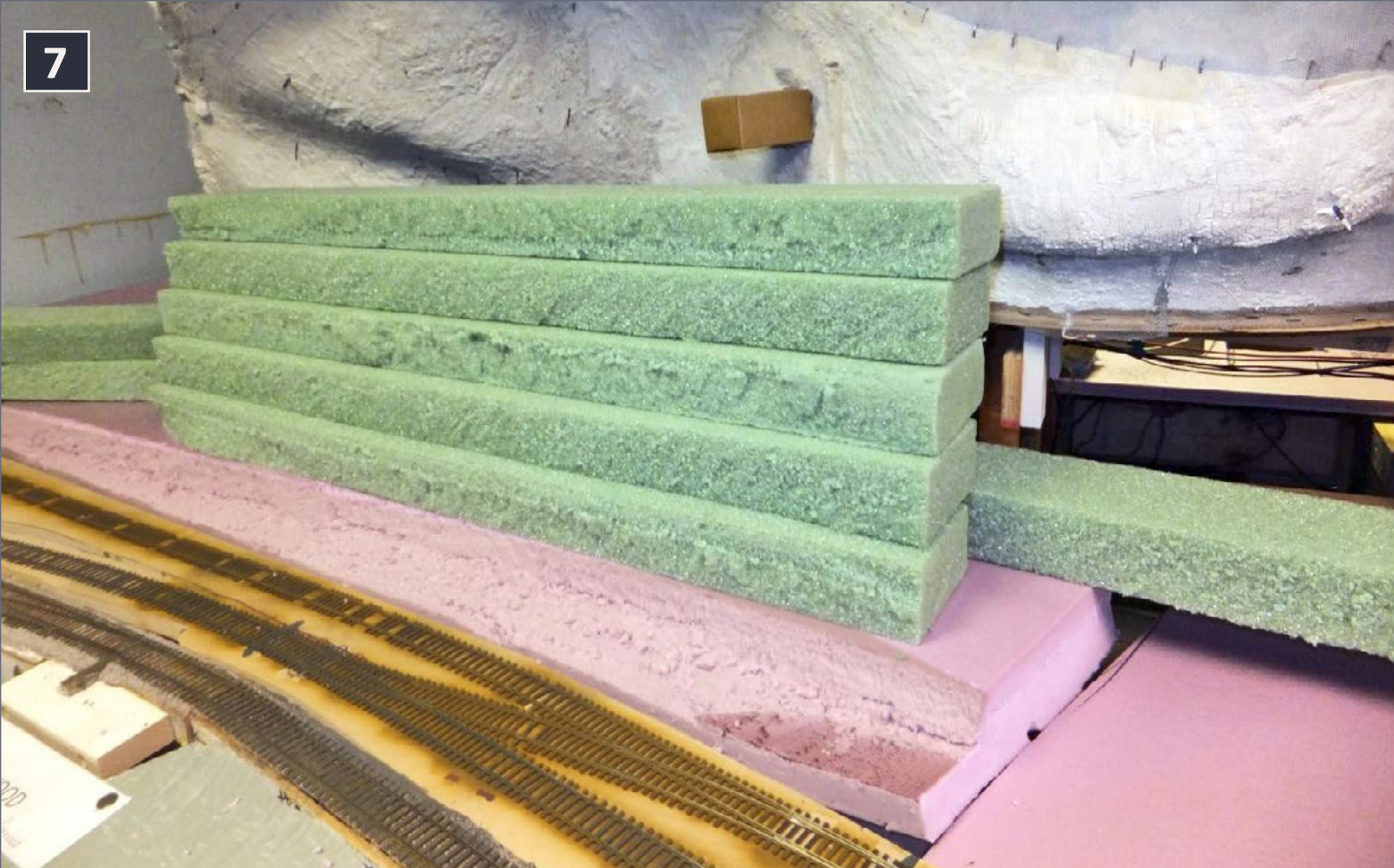

7. The green foam I bought was 2" thick, 12" wide and 36" long. We first cut it into 4" wide pieces and used the hot glue gun to stack them up in a sort of stair-step fashion.

Advertisement

*It's not just a model,  
it's a piece of history.*



**Bollinger Edgerly  
Scale Trains**

[www.besttrains.com](http://www.besttrains.com)



Email



Phone



8. Mike Confalone showing me how he carves the foam. It was immediately obvious that I should stand back!

Advertisement

**CHECK  
IT OUT!**



Announcing our **newest**  
**HO-Scale Freight Car Loads ...**



Intermountain AAR 2-Bay Hopper  
Coal



Rapido 53' Mill Gondola  
Scrap Metal



Bachmann 40' Mill Gondola  
Scrap Metal



Accurail 70 Ton 3-Bay Hopper  
Gravel

Order yours today at [www.motrakmodels.net](http://www.motrakmodels.net)





9. Here the foam is being extended to the left. It was Mike C.'s idea to curve the mountain, the opposite of what I would normally do. This created a feeling of expansiveness that would be exploited further with a backdrop photo. The cardboard cylinders are about the same size as grain mill silos and are used to get a perspective of how much room an industry will take. This is the future site of Purina Feeds in Wyalusing, now gone on the prototype but very much alive in my 1985 era.



**10. By the end of the day we had reached a logical stopping point but it was clear to me that this was a very promising way to build scenery quickly and in quantity. Bear in mind this was basically an afternoon's work. About half the time was used to mull over and discuss what needed to happen here.**





**11.** The next day I sneaked back into the layout room and spent a pleasant couple of hours cutting and fitting the foam stack to fit into existing scenery. Note the uncut piece of foam in the lower left foreground, marked and ready to cut. I couldn't resist sticking a Super Tree into the foam, noting just how easy it would be to put a forest on this hillside.

With the basic Laceyville to Wyalusing hillside transition largely in place, and feeling quite comfortable with green foam techniques, I turned my attention to the other side of the peninsula. That was a somewhat less draconian tear-apart and connected to a completed section of the layout, so I was highly



motivated to get that opposite side back under control and presentable. This next work occurred between an op session in September 2013 and the next one in early November 2013, just to give a sense of the time involved.

## **Skinner's Eddy and Myobeach, PA**

In my prior visits to the town of Laceyville, I had failed to notice that a structure I was planning to place there on my layout was actually in a place called Skinner's Eddy. Yes, you could see it from Laceyville, but both on the map and on the railroad, it is two different places! Since I was doing a partial remodel on the side of the peninsula opposite Laceyville, it seemed logical to move this structure around the corner to that side. It also kept the towns in the correct order.

On the following page, is the Conrail ZTS Map of the Skinner's Eddy area.



*The* Get the Latest Model Railroading News, Tips, Reviews & Opinions

# SCOTTY MASON

S H O W

*The Original Model Railroad Podcast*

**-Monthly Interviews**

- Modeler's Spotlight: Top Modeler's Talk
- Narrow Gauge Modeling w/Chris Lane
- Contemporary Modeling w/ Mike Rose

**-More Product Announcements & Reviews**

 Our feed has changed! To get the latest shows, Please search Scotty Mason and subscribe to the new feed!

[www.TheModelRailroadPodcast.com](http://www.TheModelRailroadPodcast.com)

*Scott Mason Jimmy Simmons Mike Rose Joe Duckworth*



contents



index

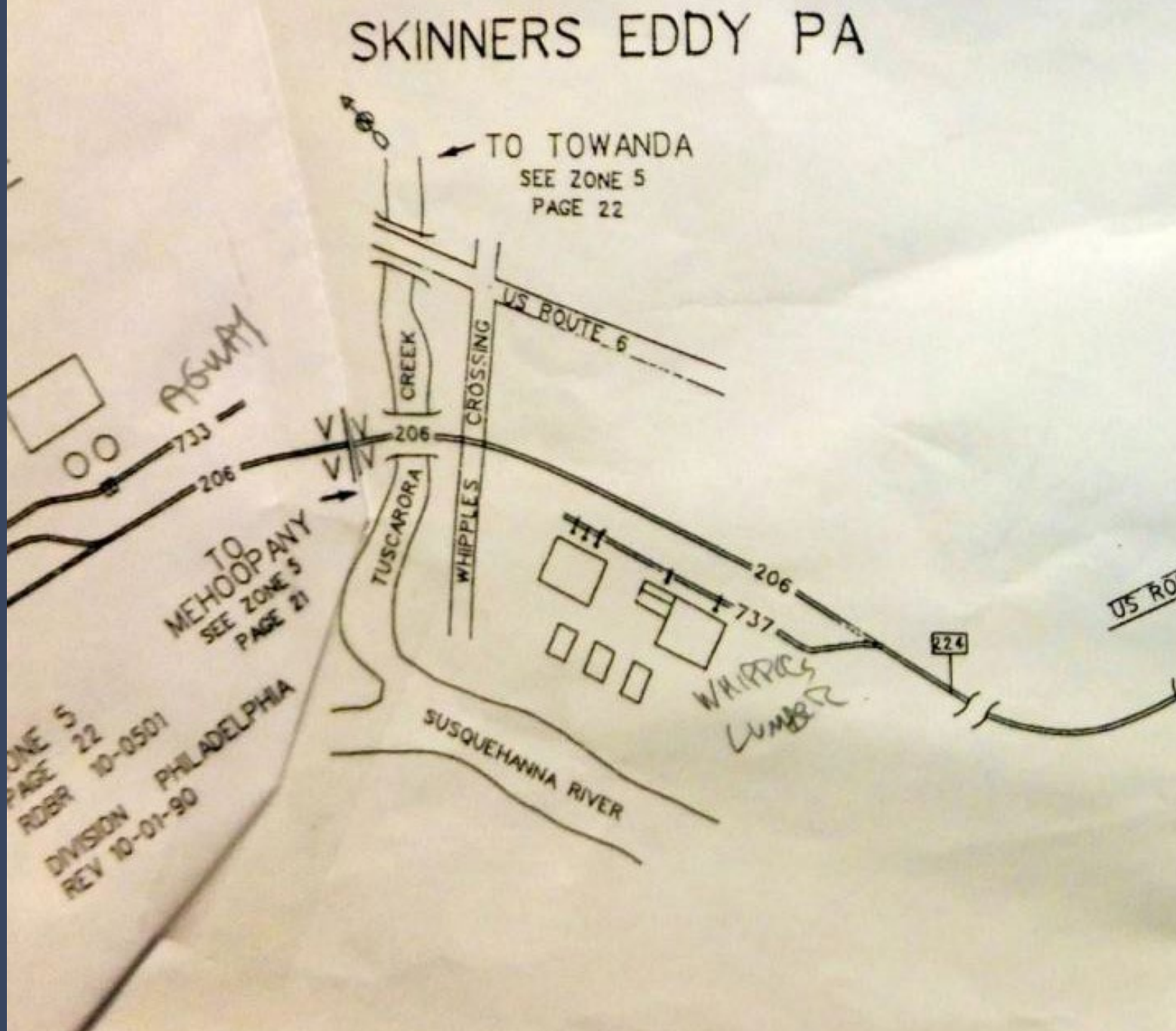

12. Note that Skinner's Eddy is just down the tracks from Meshoppen and Kintner Milling, covered in the May 2013 Model Railroad Hobbyist cover article [mrh-pub.com/2013-05-may/land](http://mrh-pub.com/2013-05-may/land). I basically bent the main line in the opposite direction to go around the end of the peninsula.

# MESHOPPEN PA

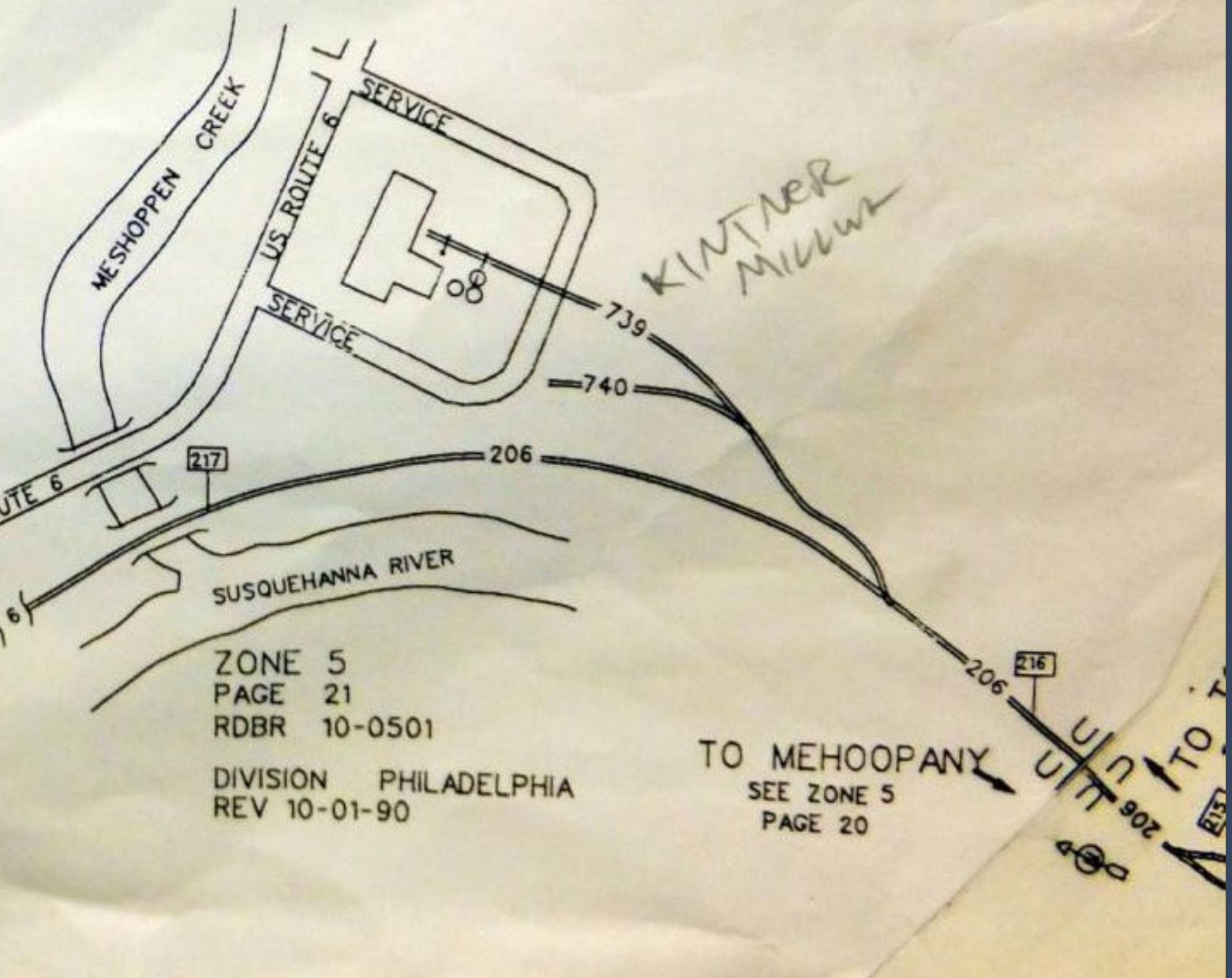

ZONE 5  
PAGE 21  
RDBR 10-0501  
DIVISION PHILADELPHIA  
REV 10-01-90

TO MEHOOPANY  
SEE ZONE 5  
PAGE 20



contents



index



13. My starting point for the Skinner's Eddy scenery looks like this. The siding and building are in place, the old scenery between the upper and lower tracks has been removed, and the old foreground scenery has been removed and is ready for fascia placement.

Advertisement

Want better looking diesels?

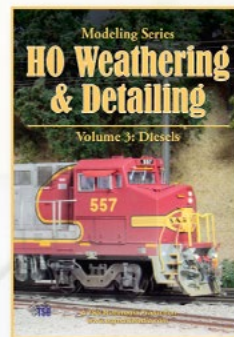

PREVIEW  
VOLUME 3

This button should link to:  
<http://tsgmultimedia.com/product/ho-weathering-detailing-volume-3/>

See two new videos about weathering, detailing and lighting, too!

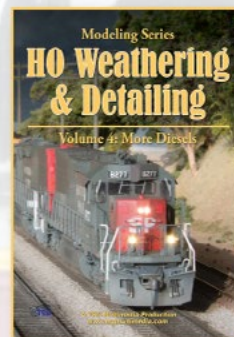

PREVIEW  
VOLUME 4

This button should link to:  
<http://tsgmultimedia.com/product/ho-weathering-detailing-volume-4/>



TSG Multimedia





14. With fascia in place, here I'm using the foam stacking methodology to fill the big gap between the upper and lower tracks. In the background you can see shorter pieces I'm beginning to use to make the corner bend. The tunnel portal has been removed (extreme left) and will be replaced with foam heavily planted with trees.

*Advertisement*

## New detail items now available

- Always made in the USA
- 7 unique lasercut Billboard Frames
- 12 sets lasercut Graffiti Decals
- 16 styles lasercut Grade Crossings
- 21 different Rooftop Billboard Signs
- 35 sets Traffic & Advertising Signs
- 37 lasercut Structures & Bridges
- 1000's of satisfied customers

WHAT'S  
NEW?



HO & N since 1993

**Blair Line**



Email



Phone



contents



index



15. I'm starting here to pre-slope the foam and glue each piece in into its place. I find it easier to do the basic shaping, and save the carving for the final stages. Note how the short pieces are extended almost to the tunnel portal, and how radically different the scene looks even at this early stage.

### Advertisement



## HO GP60S ARRIVING WINTER 2014



GP60M ATSF - 4 ROAD NUMBERS

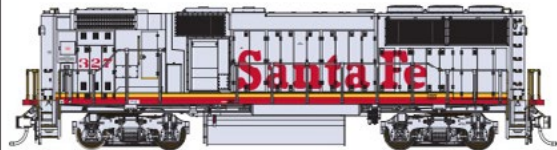

GP60B ATSF - 4 ROAD NUMBERS

NEW TOOLING  
SOUND AVAILABLE



NORFOLK SOUTHERN - 3 ROAD NUMBERS



NORFOLK SOUTHERN - OPERATION LIFESAVER

[www.foxvalleymodels.com](http://www.foxvalleymodels.com)

RESERVE  
TODAY!





16. Lots going on here as I get into a more challenging area. I was trying to save as much of the good grassy areas and ballasted track as possible, which is why you see gaping holes, finished ground and everything in between! Here I'm using pieces of regular pink foam to rough-in a small gorge that acts as a drainage ditch for several scenery areas. Ultimately, this gives a reason for the existing bridge, just to the right of this photo.



17. Can you guess what's wrapped in foil? Yes, it's the aforementioned bridge, and this is how I decided to protect it from the scenic efforts that include a new, raised river bed done with the white Sculptamold here. Note how the old scenery to the right is being joined in hybrid fashion to the new foam at the left and above. The Sharpie marker temporarily holds up a Cripplebush rock casting that will be used to cover up the plumbing soil pipe that projects from the wall. This was a very tricky area, and required me to go from double to single track accomplish this without a tunnel. I'm using foam formers and screen wire here because of what sits below the scenery in this area.





**18. I'll resort to pretty much anything handy to hold parts in place while glue dries! Here the Cripplebush casting is being bonded with Loctite Power Grab adhesive. I filed some of the pipe's flange to get a bit more clearance.**



contents



index



**19. The screen wire is screwed and hot-glued in place, making a transition between the old scenery and the new green floral foam. That's another Cripplebush shale rock casting at the lower right. This is ready for plaster cloth.**



**20. This overall shot shows a combined view of the various closeups that preceded this photo, and also the construction stage of the upper hillside.**



contents



index



**21. This opposite-angle view clearly shows the blended transition of foam to scenery construction.**



**22. I like working with plaster cloth, but the rags show how messy it is! It's nice to have the screen wire area opaque, after having been exposed for so long.**



contents



index





**23.** The drainage ditch is fleshed-in with Sculptamold that is pre-colored with earth-shade latex paint.

**24.** I took great care to use the same earth-colored Sculptamold to smooth out seams and indentations in the foam scenery. I later found out that this is totally unnecessary! In fact, I did virtually none of this on the other side and once treed, it's impossible to tell.



contents



index



**25. This close-up shows the foam “tunnel portal” that has been created, replacing the old concrete double-track tunnel portal in this location. The goal is for the train to just disappear into the trees.**





**26. Dirt! It's a good thing. This is just dried, screened dirt from my yard. I've used it everywhere on my layout as a basic ground cover.**



contents



index



**27. I couldn't resist sifting some Woodland Scenics Green Blend over everything. But this too was not needed! Again, on the other side it was totally omitted. In the past it was definitely more pleasant than looking at all that bare ground for months and months, sometimes years. But with my new attitude and fast-track tree-making techniques, these hills will not be bare for long.**



**28. No matter what, it's always desirable to work from the back to the front, so I busied myself installing trees on the upper hillside. What a difference trees make! It's only now that my layout starts looking "right" to me. My plan was to tree-in the upper part and then clean up for the op session. But I had a few more trees ...**



contents



index



**29.** As you can see, those trees started to grow in and around Skinner's Eddy. They made such a difference that I started to take trees from areas about to be remodeled and kept installing them here, trying to finish an area for the op session.



**30. This closeup shows the road, paved with lightweight spackle mixed with powdered tempera paint pigment. The ground cover is dried leaves from green tea bags! It was just what I was looking for, without the work of grinding up real leaves.**



contents



index



**31. The thing about installing trees is that the more you install, the more impact it makes, and the more you want to make more so you can install more. Vicious cycle. At this point they have spread well past the bridge. In the foreground scene I'm about to declare it sufficiently presentable for the op session. Little things like an access road, crossbucks at the grade crossing, even the bumper on the siding, all help to compensate for the fact that this scene is far from detailed, and therefore not done. I want to bring my whole railroad to this level before I go back and have fun detailing the scenes further.**

Next month we'll get back to Laceyville and elsewhere and show the results of an even bigger scenery effort!



# Never heard of TrainMasters TV?

click here to visit the TMTV  
streaming video website



**Super-saver  
pricing in  
August**

# TRAINMASTERS TV ...



Over 3  
hours of  
sample  
video

*click  
now to  
watch!*



Also coming in the next 12 months ...

- George Sellios F&SM update
- Paul Scoles memorial
- La Mesa Club Tehachapi layout
- TWO layout-building how-to series
- MRH Weekly Help Desk
- Historical prototype visits

**Exclusive!**  
**free eBooks**  
coming to  
**TMTV...**

- Structure plans
- Loco kitbashing
- Layout planning
- Prototype info
- ... and more!



Visit TMTV website



click here





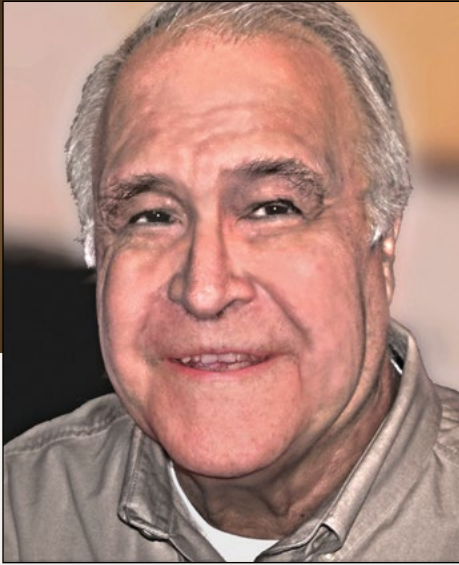

## A narrow gauge coal tipple Part 2

Ramblings on Narrow Gauge  
and Branchline Modeling



### **The Lite and Narrow column**

*by Larry Smith*

## **Modeling a real coal tipple from the East Broad Top that can be used on any railroad ...**

### **Pearson Coal Company**

**T**he tipple of the George E. Miller Coal Company at Jollar, PA was of modern all-steel construction. It was constructed in 1938, replacing a wooden trestle-like structure that had been destroyed by fire the previous year. The Miller Coal Company had begun to ship a portion of their coal by truck as early as 1932, and when the new tipple was built provisions were made for loading trucks as well as hopper cars, reflected in the design of the tipple.

The modern coal tipple is constructed for easy accessibility to the machinery inside. It's constructed of a steel framework with metal sheathing attached to nailing strips. Should a piece of equipment need to be removed, the outer sheathing can be removed, and the large equipment replaced. You also will see this type of construction in modern coal preparation plants.



I changed the model of the tipple from the original drawings published in the winter 1996-97 issue of the Timber Transfer. The changes reflect details revealed in new photos. The rear pit was eliminated and major changes were made to the steps.

The instructions and plans did not have the latest information on the tipple, so I constructed the rear wall to match the plans. The plans indicated that the rear wall was four feet wider it actually was. I first built on a diorama and then on the layout. Since it can be seen from all sides, I decided to



**1. Miller tipple in place on the diorama with a narrow gauge hopper on the inside track and a standard gauge hopper with narrow gauge trucks on the outside. The chutes still need the extensions to reach the hopper car.**



## 2. West side of the miller tipple showing the ramp to the top of the embankment and the loading chute under the main tipple.

build it using open steel construction, like the prototype, and with nailing strips.

Based on the measurements of 9" H-beams taken at the site of the Jollar tipple, I used 1/8" Evergreen styrene H-beams for the steel work. I added gussets from .020" sheet styrene to the corners and at the junctions of the H-beams, which strengthened the joints.

The cross-bracing in panel is 1/8" Evergreen styrene with .020" plates at the junction. For those center plates, I added Archer rivet decals for the X. The nailing strips are scale 2" x 8" Evergreen styrene strips glued in place at 8' intervals.



I added pre-painted Northeastern corrugated metal roofing, which is embossed paper, to the walls, overlapping the sides and bottom of the section to seal the building.

The advantages of using the paper panels are, there isn't any shiny metal showing, and it is easy to weather. This is just one way to construct the metal-sheathed part of the tippie.

In his article, Ron Pearson drew the external walls of the tippie on .060" styrene. He scribed the styrene and snapped it apart, giving him straight edges.



**3. East side of the tippie showing the covered pit that was mistaken for another shaft. The steps have yet to be installed as well as the waste chute from the shaker house.**

Ron marked the locations for the windows and doors and cut them out. He then glued Evergreen 9" H-beams in the corners. Over the styrene sheets, he applied Campbell's corrugated metal cut to 4' wide sheets.

The Northeastern and Wild West Models corrugated paper could be used with this type of construction as well, but these products weren't available at the time Ron built his models.

Those of you in larger scales may substitute either foam-core board or thicker styrene for stronger walls. Also, the Northeastern corrugated paper is available in O scale.

## **Alternative methods**

Another method for making the walls is a combination of open frame and solid styrene. For the areas where the steel work is visible, such as through the large opening at the rear of the tipple, using the open steel work so that the bracing can be seen, as in the prototype photos, and solid styrene walls when it can't.

However, using this method requires the corrugated metal or paper to be finished on both sides in the visible areas, as with the open frame type of construction. No matter which method you use, do not enclose the building over the tracks until the loading bin has been installed. This will make for much easier installation.

Once the framework was complete, I installed the dumping floor of the tipple. To better support the floor, I added additional H-beams. The floor was installed using individual 2" x 12" scale lumber and was stained with Builders in Scale Silverwood.

The mine rails come from the mine to the tipple across the ramp. To locate the mine rails, find the center of the structure



contents



index

and mark two lines to indicate where the rails are to be glued in place. My mine rails are for 30" gauge mine cars, so the rails are located 15" on each side of the center line. The rails inside of the tipple will need to align with the ramp rails when it is added.

The windows used are Grandt Line #5299 and #5276 steel casement windows. The #5299 is a nine-pane window, and the #5276 windows are six-over-six panes.

I modified some of the windows to show them in an open position. I scored along the top and sides of the window and



**4. The tipple under construction and clearances checked using the previously installed castings.**

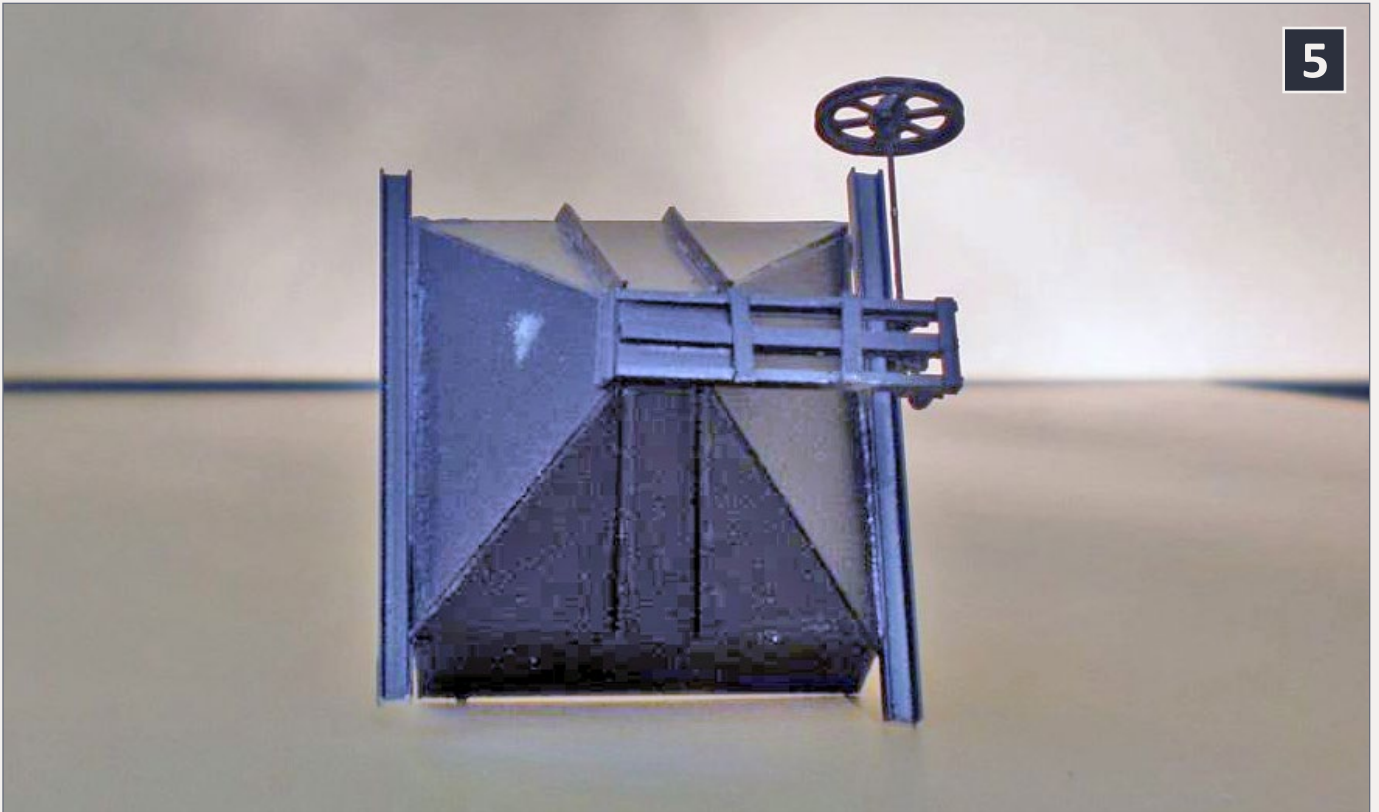

**5. The bin and chute under the main tippie with the operating pulley. It is identical to the two bins under the shaker house.**

popped it out of the frame. All windows have 6" x 6" sills added. The doors for the tippie are .010" styrene.

## **Loading chute**

The loading chute is under the main part of the structure. I constructed a bin from the dimensions of one that remained at the site after the tippie was demolished. The top of the bin measures 12' x 12' x 5'. The bin was built using .040" styrene for the sides.

To build the bin's tapered bottom, cut four pieces of .020" styrene, measuring 12' x 7½'. Locate the center of the 12' side and mark 1' on each side. Scribe a line from the corner on the opposite side to the 1' mark and then snap the piece off creating an angle. Do this for all of the remaining pieces.



When joined, they are 5' deep and form a 2' square opening. This bin had reinforcements welded to the sides, parallel with the bottom and this is simulated by gluing scale 2" x 8" styrene strips to it. Install the bin into the main tipple, letting the tapered section extend below the floor line.

Facing the track side of the building, attach .060" styrene channel to the bottom of the bin. Slide a piece of .020" styrene 2' x 3' into the channels as a hatch. Glue a piece of 4" x 6" styrene to one end of the hatch top, and add a Ragg's... to Riches rack (DP0008) on the opposite end. This is the operating rod that opens and closes the hatch.

Add 1" x 3" styrene strips to the channels to support the rod. Add the pillow blocks from the same set to the rear of the channels. Make a long shaft that will reach the inside wall, then drill a hole, and slide the pinion gear onto it. Attach a Grandt Line #5122 43" cable sheave to the end of the shaft.

A spreader bar is located immediately below the sheave. I made this from Evergreen styrene angle, with holes drilled 43" apart to guide the cable. Build a pulley bracket, using channel for the base and adding sides, then drill a #78 hole and insert an SS Ltd 12" pulley.

Once the bin was completed I sprayed the entire assembly black. On this part of the tipple, the pulley is at ground level and attached to the small concrete foundation. Thread the sheave and pulley to finish the installation. Remember this procedure, as we are going to repeat it later.

With the main part of the tipple glued in place, install the lean-to that covers the pit. These are simple triangular sides with a covering of corrugated metal for the roof.



**“Because the coal that was shipped by truck would not go through the coal washer at Mt. Union ... it was sent through a cleaner and graded ... then distributed into storage bins for loading either into hoppers or trucks.”**

The shaker house and storage bins were adjacent and attached to the main tipple. Because the coal that was shipped by truck would not go through the coal washer at Mt. Union, but it also needed to be graded, it was sent through a cleaner and a series of shakers (sizing screens). The graded coal was then distributed into storage bins for loading either into hoppers or trucks.

Begin construction of the storage bin structure by building two bins similar to the one already installed in the main tipple. Cut eight pieces of .040" styrene, 12' X 5'. Remove .040" or the thickness of the styrene, from each end of four of the pieces and glue them together making sure they are square.

Unlike the bin inside the main tipple, these have detail that is visible and must be added. To simulate the joining of plates to make the bins, divide the sides into five segments and draw lines from top to bottom.

You can either glue angle or individual pieces at the corners of each bin. On each of the lines, glue .020" x .060" styrene strips narrow side down. You need to do this for three of the sides for one bin and two of the sides for the second bin. Glue .020" x .060" strips to the bottom of the vertical strips as a flange.



contents



index

Recall assembling the tapered part of the main tipple bin. It is time to repeat those steps and assemble the two for the shaker house. Cut eight sheets of .020" styrene 12' x 9½'. These are different because these bins are higher than the enclosed one.

Again, make your cuts from the corners of the pieces toward the center, allowing for a 2' square opening in the bottom. After assembling the bins and gluing them to the 12' squares, add three scale 2" x 8" strips to three of the sides and two to the other side leaving the center open. This is where the truck chute attaches to the bin.

Cut four 9" H-beams 29' long. Glue them to the outside corners of the bin with the panels on three sides and the attach the bin



**6. The bins under the shaker house under construction. The operating mechanisms for the chutes and the outside chutes have yet to be installed.**

with the panels on two sides. Make sure the top of the bins is flat, as this is where the shaker building will sit. Cross-brace the columns with 9" I-beams and put a slice plate in the center. At the bottom of each H-beam, glue an 18" square of .020" styrene, and the put gussets on each leg. You can add Archer rivet decals to the gussets for added detail.

The truck chutes are fabricated from .020" styrene. The upper section which attaches to the bin is one piece, 2' x 7' for the floor and two pieces 1' 6" x 7' for the sides. These are built the same way a coal chute is made for coaling towers.

The chute extends from the bin through the support bracing, and is held in place by attaching .030" styrene rod to the sides and then cross-bracing with scale 1" x 3" styrene. The lower section of the chutes can be raised or lowered, so they are hinged just beyond the support cross-bracing. Pulleys and cables were added to allow workmen to operate the chutes from the ground, and load hopper cars or trucks, depending on what was spotted at the chute.

## **More black paint**

I spray-painted the entire assembly black and touched-up the gears and track with a silver marker. After drying, I attached the concrete footings to the H-beams.

The shaker house is located on top of the storage bins. Begin by cutting and gluing a piece of .020" styrene to the top of the finished storage bins. Cut four pieces of .040" styrene 3' tall and 12' wide. Mark the center of the pieces and measure 5' on each side. Scribe a line from the 5' marks to the corner of the 12' side, and snap off to make an angle.

Glue the four pieces in place at each end and in the center. Enclose the top and sides with .020" styrene. Glue corrugated



contents



index

metal strips to sides and ends with an overhang at the end of the building.

The shaker house is 10' wide and 26' long. The front wall of the tower is 10' x 22' and the rear wall is 10' x 18'. The rear wall is attached at the top. The side walls are 12' wide with one side 22' and the other 18' for the roof angle.

The sloped portion of the building is connected 14' from the floor on the 18' side. All roofs have Wild West Models corrugated siding strips attached to the eaves to seal the building.

I measured the ramp from the tipple to the embankment to fit the gap between the structure and the start of the slope. This will vary from model to model, due to differences in scenery



7

**7. The mine car scale house showing the simple construction of the building. In the background are two of the mules, Maude and Esmeralda, who, along with 23 others, are the motive power for the mine cars at the tipple.**

methods. The construction of the ramp is the same. I used 2" x 8" lumber set 2' apart on 12" x 12" timbers for the joists. I used 2" x 12" boards for the flooring. I cut 12" x 12" timbers on an angle, and used them to support the ramp running from the center cross beam down to a 12" x 12" beam glued to the tippie at the top of the retaining wall.

In reality, large nut and bolt castings would have been used to attach the beam to the tippie, but in this case they would not be visible, so they were omitted. You may add them if you wish. Once this was in place, I added Central Valley fencing as a guard rail to each side of the ramp.

## **Mine car scale house**

The scale house for weighing the mine cars is an integral part of the operation of this tippie. Weighing was done between the mine and the tippie. The scale house is seldom modeled, but it was very visible at this mine, and is a necessary element in the overall scene.

I began by drawing the base and location of the scale track. The scale house is divided into two sections – the enclosed 7' x 14' section, and the open section with the same dimensions.

The original structure was sheathed with 6" tongue-and-groove siding, so I used scribed siding. The two end walls are 14' wide and 10' 6" tall at the center peak. The side walls are 8' at the eaves. Measure in 7' and remove the material, leaving an open space for the track. The rear wall is 8' x 14' and the inside wall is 10' 6" x 14'. Draw the base on paper 14' x 14' and draw the track center line 3' 6" from the edge. I used 30" gauge track, and glued the code 40 rails with CA.



contents



index



# Come and see our Savings Today!

*(while supplies last)*

## Click NOW!

**HO**

**DCC**

**ALL SCALES**



*- Kadee - NCE - SoundTraxx  
- Digitrax - And more!*



The flooring is 1" x 10" lumber and after drying was stained using Builders in Scale Silverwood. I placed 6" x 6" at the corners, and installed Grandt Line 5131 doors, along with a four-over-four window from my scrap box.

I painted the entire structure boxcar red. The roofing material for this and all of the other support structures is BTS French shingles. These diamond-shaped shingles were common on Broad Top area structures, so you will see them used consistently for the other structures in this series.

After applying them to thin scrap scribed siding, I painted the roof black and installed it.

Next time we'll look at the other support structures and how they relate to the overall operation of the Jollar tipple.

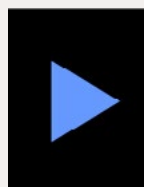

**Reader Feedback**  
[\(click here\)](#)





**Many species of  
Conifer trees available!**



**Lodgepole  
Pine**



**Green  
Spruce**

**Blue  
Spruce**



**Click for  
more -  
lots more!**

**Also see our other  
conifer offerings ...**



Email

Phone

contents

index

# Building a movie set

## The camera is your best friend, or your worst enemy when it comes to modeling ...

**T**he late Frank Ellison made the statement that model railroading is like the theater. The layout is the stage, or set, and the trains are the actors entering and leaving the scene as the script demands. This comment is true and we all build our stages, or sets, to act out our own dramas or comedies depending on what occurs.

In July, 2012, I received a phone call from a local film company asking if I could build a set for them to film a commercial. I was curious and agreed to meet with and show them some of my modeling work. They took photographs and were surprised at the detail that could be obtained at that scale, HO, having never seen a scale model railroad up close. At that time we had talked about what they were looking for and the concept of the set.

The producer did a sketch of what they wanted and the shooting parameters, in other words the visual field of the camera. What developed for that first shoot was a 4' x 30" box with scenery base rising towards the rear and to the right side facing from the front. It was to be a western desert scene and it would be built in HO scale.

The scene included a corral and fencing from Scenic Express. I received a call from the studio asking how high the fence was. They explained that they were in Atlanta and were videoing cowboys against a green screen for insertion into the set. For those of you who aren't familiar with it, a green screen is a large green background where live action can be filmed or videoed and then imposed on another set or background.



Shooting day arrived and the studio picked up the set. I was invited to the shoot and followed them to the location: it was an interesting process to watch. The photographer removed or repositioned cactus and plants to get a better shot and we also removed a line of rock casting that I had placed along the back edge. One of the casting ended up over 2' behind the set held in place with clamps. All of this was shot against a red sky backdrop. It took over eight hours of shooting to get a 30 second commercial and this didn't include the edit time!

This commercial was for a Subway® sandwich called the Bull. I was amazed to see my work close up with real humans walking through the realistic scene. In the scene I had placed a Vulture on top of the car, but they inserted a real vulture taking flight. You couldn't tell the difference from the models! ■



contents



index

**NEW!**

# FREIGHT CRATE

Rolling Stock Transport Box  
Secure storage and transport for your delicate models



You have invested heavily in your collection of rolling stock, now you can transport and store them confidently

with Fast Tracks

## FREIGHT CRATE

- ☑ Stackable
- ☑ Secure, locking lid
- ☑ Assembles in 15-30 minutes
- ☑ Pre-cut bubble wrap cradles included
- ☑ Precision cut from 1/8" hardboard
- ☑ Easy to assemble tabbed construction
- ☑ Designed to fit equipment precisely - no compromises necessary!



Click here to visit Fast Tracks and order your **FREIGHTCRATE** today!



**FAST TRACKS**

www.handlaidtrack.com  
service@fast-tracks.net  
1-888-252-3895





# The BLMA signal tower shoot

Tips and tricks for designing a convincing scene

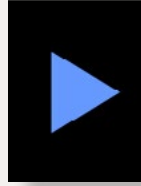

Reader  
Feedback  
(click here)



**What's Neat This Week column**  
by *Ken Patterson*

1



1. This BLMA signal tower started out on the title page for “Signals” in a Walthers catalog. Now the creation of this scene has become the subject of this month’s “What’s Neat” video. Enjoy.



**T**his month's What's Neat video is a how-to on designing scenes from the ground up. Planning is the key to having the final perfect result, every time.

I walk you through, from the photo concept drawn on paper to the construction of a scene through the camera's viewfinder. Not just any scene, but locomotives are coming off crossovers whose positions in the photo frame are dictated by the signal towers. In the video, you will see how to handle that trick through selective track laying.

The process then went through topography carving with a pruning saw, and sealing the foam. Then, gluing the track to the scene complete with ballast, dirt and scenery grass. Designing the background on the fly follows, with a total

[... On to next page of text →](#)

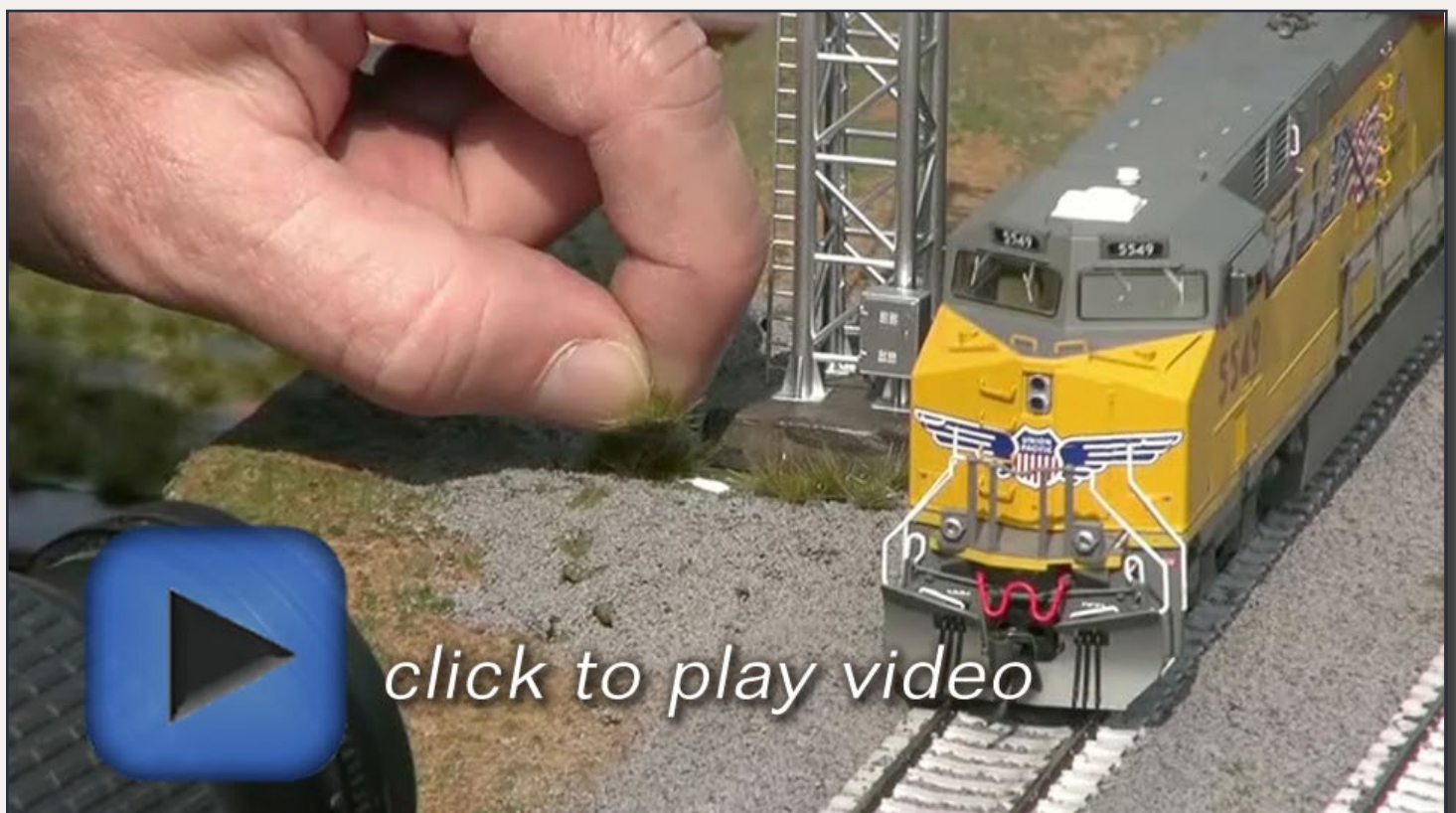

**Playback problems? [Click to try a different version.](#)**



**PWRS** 

# Announcing our next Limited Run PWRS / Micro-Trains® Cars!!!

## Canadian Pacific (CP) 40' Boxcar 4-Pack w/ Coopered Grain Doors - Stacked Block Lettering

Set Features  
2 Paper / 2 Wood  
Coopered Grain  
Door Inserts



**COMING**  
February 2015

"Coopering"...before the popularity of covered  
hoppers, boxcars with tear away doors made of heavy paper,  
cardboard or scrap lumber were used to transport grain.

## **NEW!!!** Canadian Trailer & Flat Car Series Canadian Pacific (CP) - 57' TOFC 3-Packs

Set #1 - Features  
1 Smith Transport &  
2 CP Transport Trailers



**COMING**  
February 2015

Set #2 - Features  
3 Different  
Canadian Tire Trailers

PACIFIC WESTERN RAIL SYSTEMS  
**SPECIAL RUN CAR**

**Pacific Western Rail Systems**



[← back to previous page of text ...](#)

explanation of set-up on shoot day and all the tips and tricks that are used in the last minutes.

I show in detail how to shoot a ten-stack set to give great depth of field with Helicon Focus. This video gives up all the tricks of the trade of model railroad ad design. Jump in, the water is fine.

2a



**2a-2b.** A scene on my HO home layout features a BLMA bridge crossing a river. I cut the piers from basswood and finished this scene last month to shoot ad photos for the model press of a new truss bridge BLMA is introducing. The clouds really make this photo for me! Ken Patterson photo.



Photo courtesy of DaveMinshall

# YEAH, ITS TRUE WE HAVE A SINGLE TRACK MIND.

The ALL NEW HO SCALE SINGLE TRACK ON SNOW PLOW...WITH OPERATIONAL WINGS!

Features include:

- KADEE couplers
- correct trucks
- CODE 88 stainless steel wheels
- real chains
- operational wings
- ESU equipped decoder
- Available in CN and CP
- correct plow contour
- interchangeable cupola
- finely detailed
- Lights
- unique sound and horn

SCAN ME TO GET UPDATES!

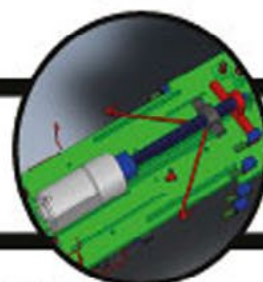
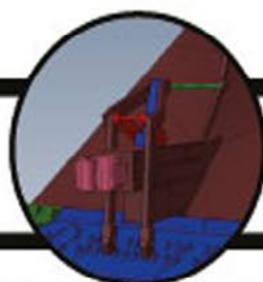

True Line Trains Exclusively distributed in Canada by Canadian Hobbycraft Ltd. 445 - 1 Edgeley Blvd, Concord, Ontario L4K 4G1  
For More Info, Please Call (905) 738 - 6556 or find us online at [www.truelinetrains.com](http://www.truelinetrains.com) Dealer Inquiries Welcome









contents



index

# MRH HOBBY MARKETPLACE - 1

Don't settle for lifeless signals!  
We've got signaling circuits!

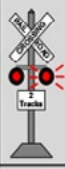

**LOGIC RAIL**<sup>TM</sup>  
TECHNOLOGIES

"Sophisticated  
Model Railroad  
Electronics"



Please visit our website and online store!

21175 Tomball Pkwy  
Suite 287  
Houston, TX 77070

Phone: (281)251-5813  
<http://www.logicrailtech.com>  
[info@logicrailtech.com](mailto:info@logicrailtech.com)

## Have you seen these popular blogs on the MRH website?



## An Affair with Trains



Tuesday-Friday: 10:00 am - 5:30 pm  
Saturday: 9:00 am - 5:00 pm  
Closed Sunday and Monday

**Your Arizona  
Model Railroading  
Headquarters**

301 W. Deer Valley Road  
Phoenix, AZ 85027-2117  
623-434-6778

Shop Anytime At Our 24-Hour Web Store:  
[www.aawtrains.com](http://www.aawtrains.com)

## Mr. Detail Parts



New Parts Added Weekly!

[Click Here](#)

[www.mrdetailparts.com](http://www.mrdetailparts.com)

## Ken Glover's Shelf Layout

44,000 reads

[CLICK TO READ IT NOW](#)



## Mike Rose's N scale empire

46,000 reads

[CLICK TO READ IT NOW](#)



CANYON CREEK  
SCENICS



# MRH HOBBY MARKETPLACE - 2

## True Scene™ Modeling

**NEW FusionFiber™**

Scenery Base Material for the 21st Century!

**SATISFACTION GUARANTEED!**

[www.truescene.com](http://www.truescene.com) or 716-523-7305

## Great Decals!™

FEC, Interstate, Virginian  
Railway, & L&N Titles  
After Hours Graphics Line  
Coupler Gages and More  
In O, S, HO, and N Scales



## Premium Trees at Bargain Prices

**Click NOW**



[www.jelsma.com](http://www.jelsma.com)

1-904-221-3513 • Jacksonville, FL.

Railroad Art-Prints,  
Caps, Jackets,  
Shirts and More ...  
Jackets starting  
at \$79.95

## Minimalist Model Railroad Design

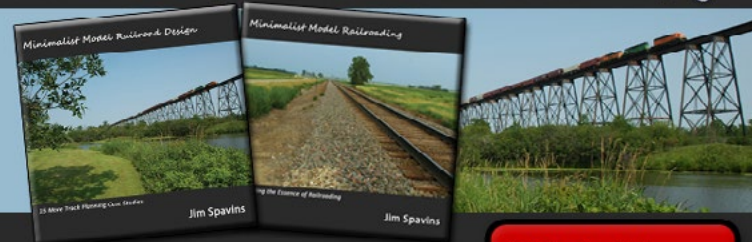

All New 2nd Edition!

**Click Here**

## STREAMLINED BACKSHOP

Sales  
... Services  
..... Solutions

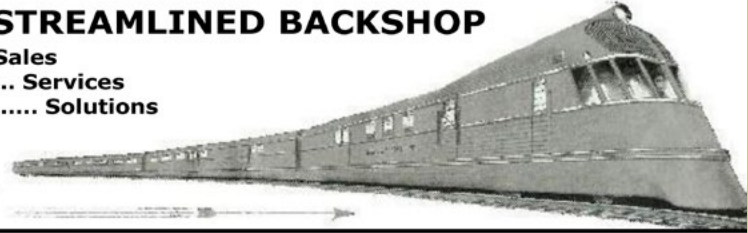

## Tsunami® TRAIN SOUND CARS



Tsunami®  
SoundCar™



- READY-TO-RUN CARS
- SOUND CAR KITS
- SOUND CAR PARTS

[www.SBS4DCC.com](http://www.SBS4DCC.com)

## Backdrop Junction

Your stop for  
Model Railroad Backdrops



 [click here to visit our website  
backdropjunction.com](http://backdropjunction.com)

**N, HO, O Scales • Custom Orders**



# MRH HOBBY MARKETPLACE - 3

MRH dared to put  
*THIS* on video?



Watch the  
video now



**only \$5.99**

**only \$7.99**

*-try-*  
**Coastmans**  
Scenic Products

Rail Design Services

## Railroads Done Right!

[click HERE to learn more](#)

### **RULERS-of-the-WORLD**

Scale Rulers \$4 each

Over **150** scales!

Metric or Imperial

[www.rulers-of-the-world.com](http://www.rulers-of-the-world.com)

## Get your large text ad here in this space!

Ordinary text ads are limited to 100 characters, but if you'd like to do a double-text-ad, we'll give you 375 characters. (This ad here had right at 364 characters.)

If you have more you'd like to say, then a double-text-ad is a superb, very affordable way to say it. Place your double-text-ad with us today and start getting the word out to our audience of over 110,000 unique device views per month!



# MRH HOBBY MARKETPLACE - 4

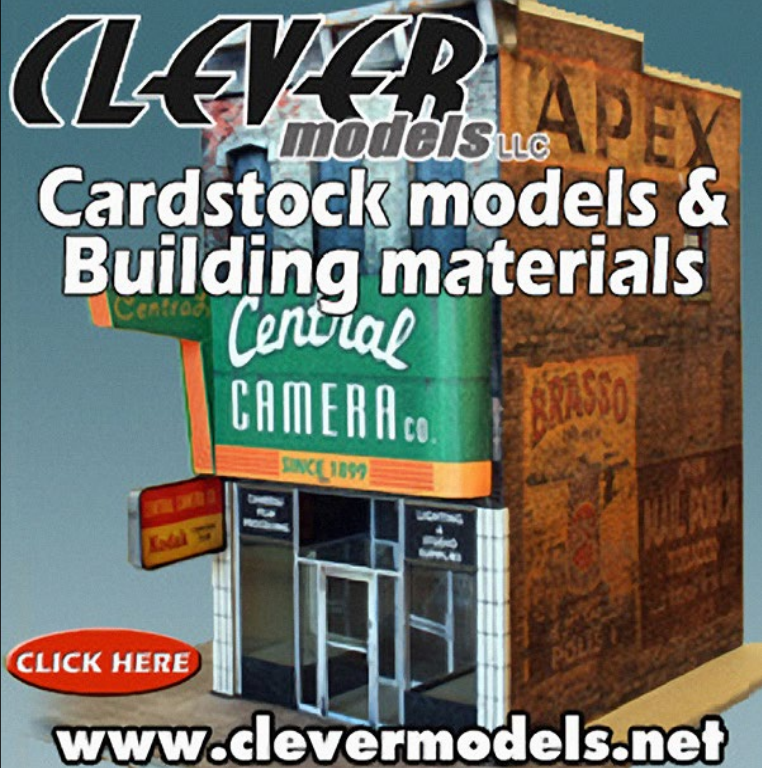

**CLEVER**  
models LLC  
Cardstock models &  
Building materials

CLICK HERE

[www.clevermodels.net](http://www.clevermodels.net)

Can't remember which cars you've bought?

**Yard Boss**

**Model Train Inventory Software**

from DCC by Design

Under \$15

Download free trial now

[www.dccbydesign.com](http://www.dccbydesign.com)



**WE MAKE OVER 900  
STEAM ERA FREIGHT  
CAR KITS!**

**NEW KITS AVAILABLE.  
RESIN KITS, DECALS,  
DATA DISKS & DETAIL  
PARTS AVAILABLE.**

**[westerfieldmodels.com](http://westerfieldmodels.com)**



A Real Train Store with Real Train People

[www.TrainMasterModels.com](http://www.TrainMasterModels.com)

Free Shipping on Orders \$75 or more in the Continental USA

601 East Main St., Buford, GA 30518 678-546-3600



**Yarmouth Model Works**

HO scale resin kits and detail parts

----- U.S.A. MAILING ADDRESS

3560 Pine Grove Ave. Unit 617

Port Huron, MI 48060

Tel. 519-633-7574

[pierre.oliver@start.ca](mailto:pierre.oliver@start.ca)

[www.yarmouthmodelworks.com](http://www.yarmouthmodelworks.com)

----- CANADIAN MAILING ADDRESS

85 Hiawatha St.

St. Thomas, ON N5P 2T5

**Hobby Marketplace  
Ads are  
Economical and  
Effective.**

***Click to learn more ...***



# Realistic “rustbucket weathering”



– by **Gary Christensen**  
Photos by author





contents



index

# Extreme weathering without an airbrush ...



If you are the type of model enthusiast who likes to weather freight cars and locomotives, yet don't own an airbrush, a plethora of expensive equipment, or artist media to get the job done – then we certainly have something in common. I will show how I go about weathering models without using an airbrush or spending a lot of hard-earned cash on paints, decals, parts, etc.

I have always gravitated toward the challenge of the “extreme” when weathering. As I begin a weathering project, I find prototype reference examples of the more heavily rusted and decrepit freight cars. So, in testimony to my preference for severely weathered freight cars to replicate, I chose a Soo Line prototype photo and purchased the newer release of the Fox Valley 7 post-Fond du Lac shops 50' boxcar in the white paint with red door color scheme.

The Fox Valley model in comparison to its prototype is a VERY accurate version. The tooling and detail are precise and true to prototype drawings. Having the Fox Valley car in hand, I saved time by not needing to add any details outside of air hoses, pin lifters (uncoupling levers), and Sergent scale couplers. I could cut to the chase and begin the extreme weathering of the model.

Before I start weathering any model, I search the Internet for various rail car equipment photo sites in hopes of finding a reasonable prototype example of the car I wish to replicate. In the





## 2. Soo 16916 is seen on another day headed back to the midwest as it wanders the rails of North America.

case of this particular Soo Line boxcar, I came across a photo of SOO 16916 taken by railfan photographer Steve Brooks [canadianfreightcargallery.ca/cgi-bin/image.pl?i=soo16916&o=soo](http://canadianfreightcargallery.ca/cgi-bin/image.pl?i=soo16916&o=soo). I was instantly attracted to the 16916 because of the very obvious rust damage and the vibrant graffiti adorning its side. Once I secured the photo of 16916, it was off to the workbench. I put some of my favorite music on the stereo in my studio, brought out the model, and commenced on the weathering.

I work on my models in fragmented sections. This means I do one side completely, one end completely, the undercarriage completely, and so on. This is the method that works best for



contents



index

me, but you should determine what works best for you. Since I am right-handed, I work left-to-right to avoid resting my hand on a section of freshly applied weathering. Left-handed individuals should work right to left.

The very first step in my weathering process is to merely wipe the car clean of any dust. While some weathering buffs insist on giving the model a bath in clean soapy water, and drying it thoroughly before getting started, I never felt this procedure was necessary, since the model will be getting dirty anyway.

So here is the Fox Valley model ready for weathering. The reporting mark numbers on this model will be removed or painted over, and the car will receive its new number 16916 with set of number decals from a Microscale sheet at a later point during the weathering.

Next, I gather the media I will need to get the weathering as close to the real thing as possible. As I mentioned, I never spend much money on art supplies. I believe it is how the

3



**3. This is the Fox Valley model direct from the box, ready for weathering.**



#### 4. The media that will be employed for this project.

media are used, as opposed to how much money is spent, that fine results CAN be realized.

In [4] you can see the basic artist media that I used for this project. Beginning from the left, I have three inexpensive fine-line soft-hair brushes and a soft-hair wide brush. Next my favorite oil paint, a tube of Graham & Co. “Transparent Orange Oxide” oil paint. This color of oil pigments is hands-down the most valuable medium in my art supply cache. Next are three very inexpensive colors of acrylic craft paints. The colors I used are Black, (not pictured) Burnt Sienna, Ivory White, and lastly, Charcoal Gray.

These colors come in bottles that can be purchased at nearly any department store for mere pennies. Finally, a set of equally



inexpensive soft pastel sticks manufactured by Alpha Colors. The pastel sticks in this Earth Colors set can be purchased at any art supply outlet, and are invaluable when used as a powder. The way I use them is to scrape the sticks lengthwise with a utility razor blade to create small piles of fine powders.

Now that I have covered the essential artists media to be used, it's time to get started on the weathering the model.

***Want to keep  
MRH free?***

***CLICK on ads.***

***If ads in MRH don't get clicks, then advertisers  
won't advertise with us, it's that simple ...***



## STEP 1: Beginning with Dullcote



### 5. The model receives a primary misting of Dullcote.

The model will receive a generous misting with a matte finish of Testors Dullcote. The Dullcote finish serves not only as a sealant, but it also provides “tooth” to the surface so that paints and other media adhere to the otherwise smooth and somewhat oily plastic. I usually speed the drying time of this first layer of Dullcote and all of the other wet finishes with a space heater. This type of rapid-drying system can prove disastrous if the model is held too close to the heater. As a rule, I hold the model about eight inches away with the fans turned on high. This provides very rapid drying, and allows me to move onto the next sequence of steps quickly.



contents



index

## STEP 2: Applying the fade Dullcote

6



6. Apply a light single layer wash of an off-Ivory White acrylic craft paint.

This next phase is probably one of the most important in all model weathering – applying the fade. All real freight cars fade to some degree due to long years of service in harsh elements. Our models need the same fade treatment. With its initial misting of matte finish, we can move on to fading the car with an off-Ivory White acrylic craft paint. I put a generous drop of this paint on a palette. With the clean wide brush, I introduce a fair amount of clean water to the puddle of white acrylic. I always keep a cup of clean water on my workbench for these weathering projects.

## STEP 2: Applying the fade *Continued ...*

Once the Ivory White acrylic is thinned to a very watery consistency, I start brushing it on with the soft wide brush, in long even strokes from left-to-right. I allow gravity to let the watery paint run down the vertical ribs and face of the model to pool at the door tracks and other raised areas on the lower car sill. This produces a very even coat of the acrylic fade. Now that a decent coat of the fade has been brushed on the model, I use a dry, wide brush to remove the excess that pooled on the lower area. Once the fade is dry, I mist the model with Dullcote to permanently capture the effect. Just be aware, some models differ in fades, requiring more applications than others. This boxcar required only one layer to fade the car to the level I wanted.



contents



index

## STEP 3: Applying the rust bleed-off

7

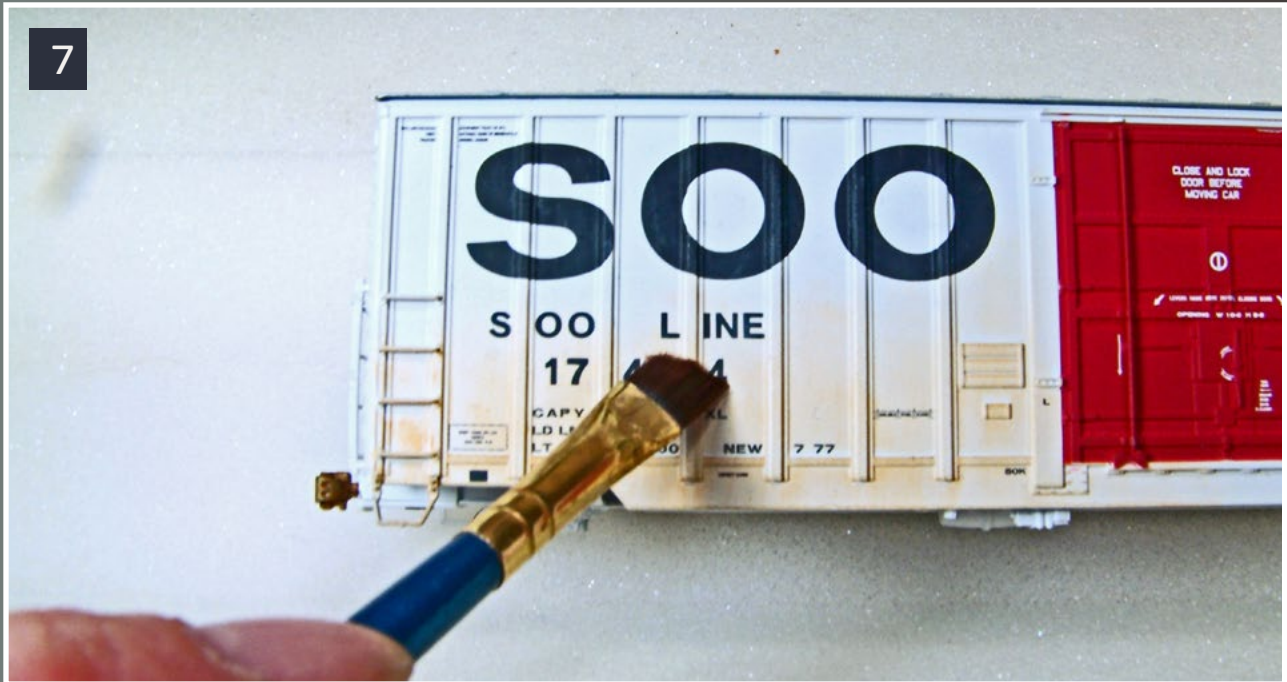

### 7. Dry-brushing a light Orange Oxide colored oil paint.

Now that the car has been faded, I move to the next phase. This step requires the use of the Orange Oxide oil paint. With a dab of the oil paint on a palette, I use a different semi-wide, angled hair brush, picking up a “mere mention” of the oil paint. I then wipe off most of the oil paint from the brush onto a white index card. Wiping the excess paint off the brush onto a card is the perfect way to see how much paint will be applied to the car. I always uphold the “light-to-dark” factor when I weather, so in this case, I dry-brush a very light layer of Orange Oxide oil paint onto the entire lower car body. This serves as a base for the heavy rust bleed-off that follows in upcoming steps.



## STEP 3: Applying the bleed-off *Continued ...*

8



8. Blend any brush strokes with a large, soft makeup brush.

After lightly applying even applications of the dry-brushed oil paint, I use a very wide soft hair makeup brush (with the oil paint still wet) to blend away any tell-tale brush strokes. With this process now complete, I mist another Dullcote application to seal it.



contents



index

## STEP 4: Adding corrosion and damage

9

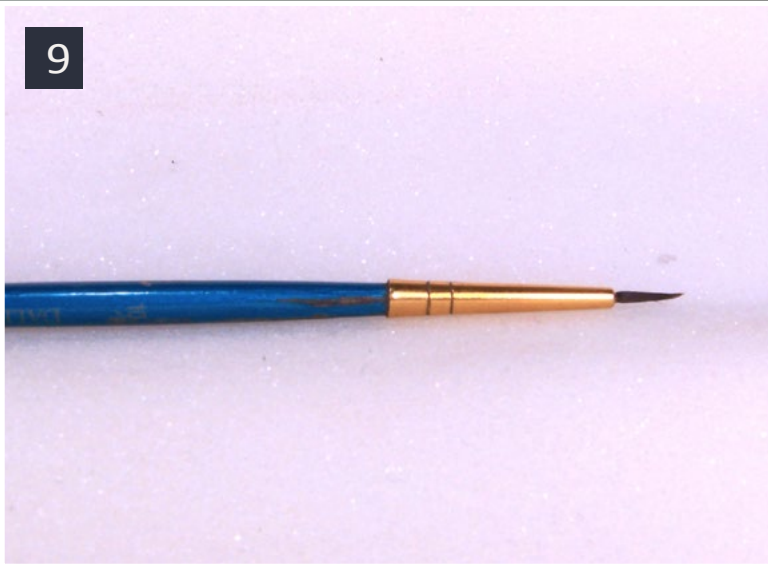

9. Using a fine brush to paint the rust scratches and rust pitting.

10



10. Adding a drop each of dark Charcoal Gray and Burnt Sienna for the rust pits.

Now comes the fun but tedious stuff! This is where I put my finest brushes to work. With the fine liner brush cleaned and ready, I place a drop of Burnt Sienna and a drop of Charcoal Gray acrylic paints on the palette. Adding water again, I mix the two colors to a fairly thin ratio. Once complete, and with my prototype reference photo at the ready, I begin the process of painting the scratches, scrapes and rust pits.

## STEP 4: Adding corrosion and damage *Continued ...*

Painting the corrosion and damage on the car is easily the most time-consuming stage of the weathering process. I perform this step while studying each scratch, scrape, and pit on the prototype photograph. After the primary layer of the damage is painted, I paint a second and even third layer to insure complete coverage.

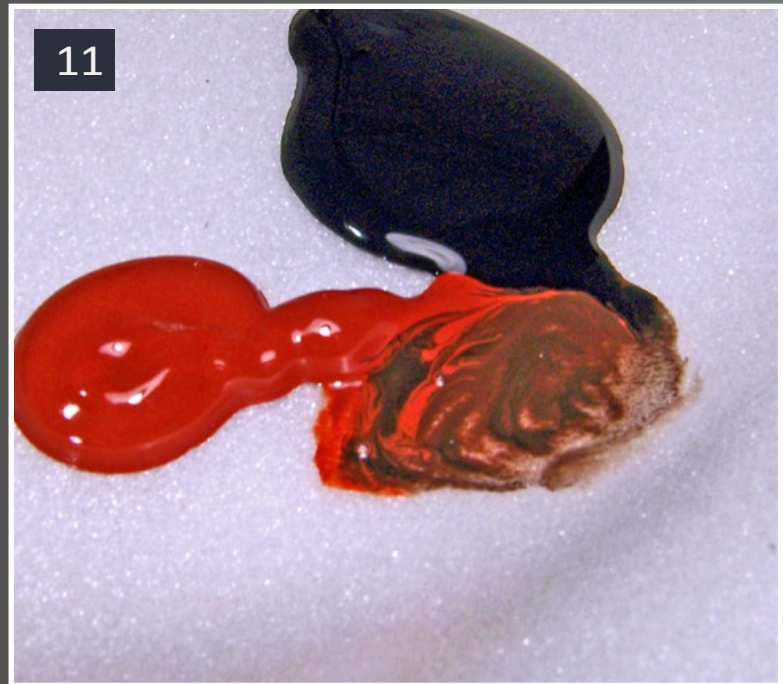

11. Mixing and thinning the two colors.

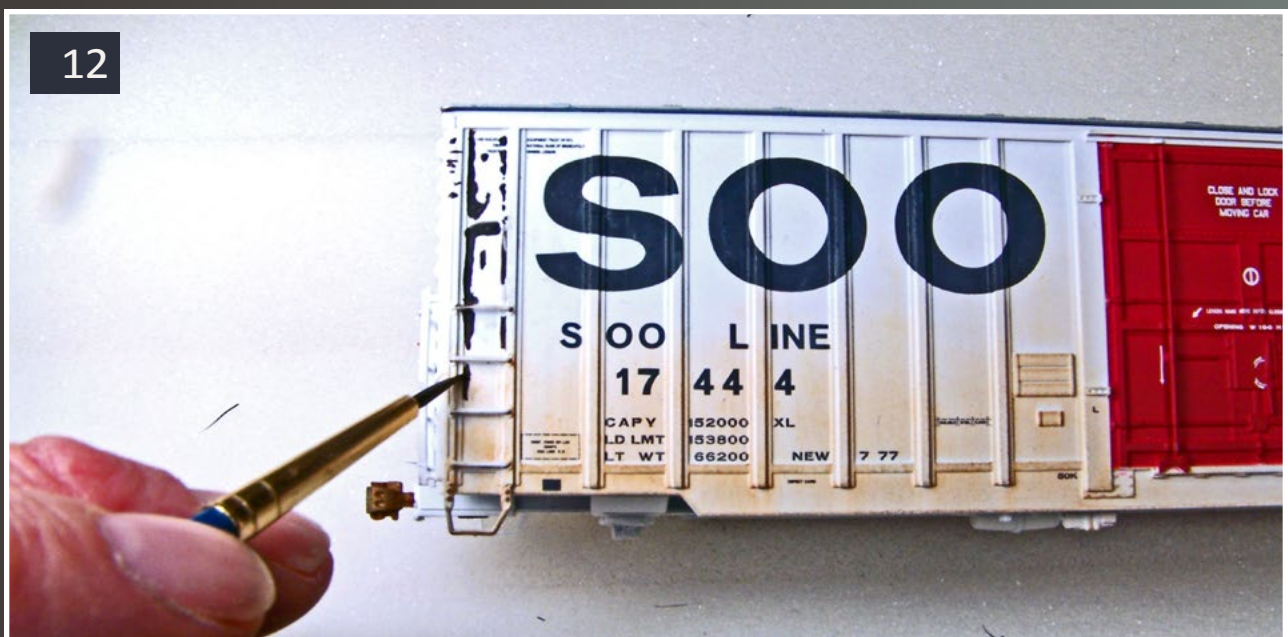

12. Using a fine brush to paint the rust scratches and rust pitting.



contents



index

## STEP 4: Adding corrosion and damage *Continued ...*

13

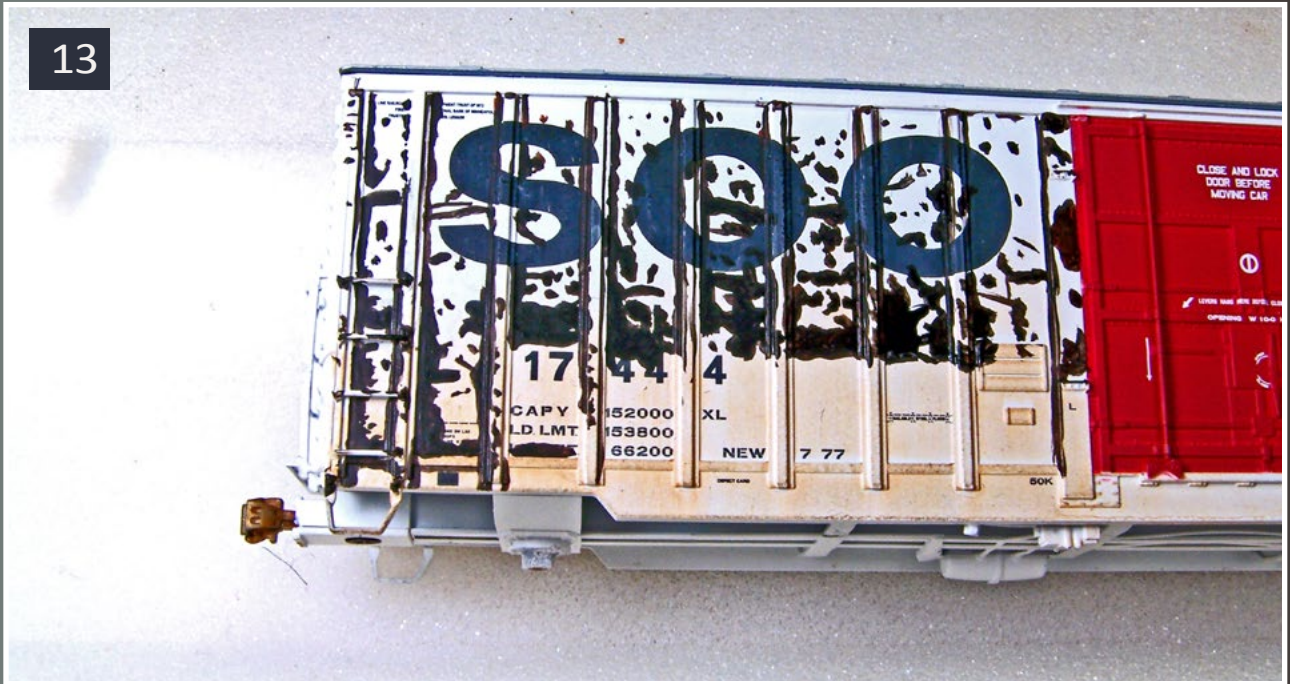

13. The rust damage and corrosion is complete and ready for another Dullcote application. Another application is added before the next step.

When all of the replicated damage meets my expectations, I mist the work again with another shot of Dullcote. Now that the model has its telltale rust pits and other damage, I can move to step 5.

## STEP 5: Haloing

14



14. Dry-brushing the Orange Oxide oil paint in a halo effect around the sealed rust pits and scrapes.

Many model weathering artists refer to this next step as “haloing.” What is haloing? It is the overlapping application of light dry-brushing of oil paint directly over existing painted work. In the case of this model, I dry-brushed Orange Oxide in multiple layers around EVERY scratch and rust pit! That's right – around every single rust pit, scratch and other simulated damage. The intense work that goes into haloing each scratch individually provides the most realistic weathering results, in my opinion. In [14] we see the advancement from left to right of the “haloing” effect on each scratch and pit. When the entire side of the car has been haloed, I mist it again with Dullcote and prep myself for step 6.



contents



index

## STEP 6: Weathering the door

15



15. The corrosion and damage has been added to the door as I work my way from left to right across the car.

## STEP 6: Weathering the door *Continued ...*

It's time to bring the battered plug door of the car to life. To do the door weathering, I basically repeat the same steps I have applied to the rest of the car. I weather the door as a separate component using a Terra Cotta acrylic craft paint. I use layers to bring about the faded salmon pinkish hue of the bright red door.

Using the same burnt sienna and black acrylics, I repeat painting the damage, and halo the damaged areas. In the indented areas of the door, I lightly brush on and feather a fine black/brown pastel powder scraped from the Alpha Color sticks. [15] you see the completed door. You might wonder why I left a huge square patch untouched to the left hand side of the car. That is where a large colorful graffiti piece will be painted.



contents



index

## STEP 7: Completing the rust

16

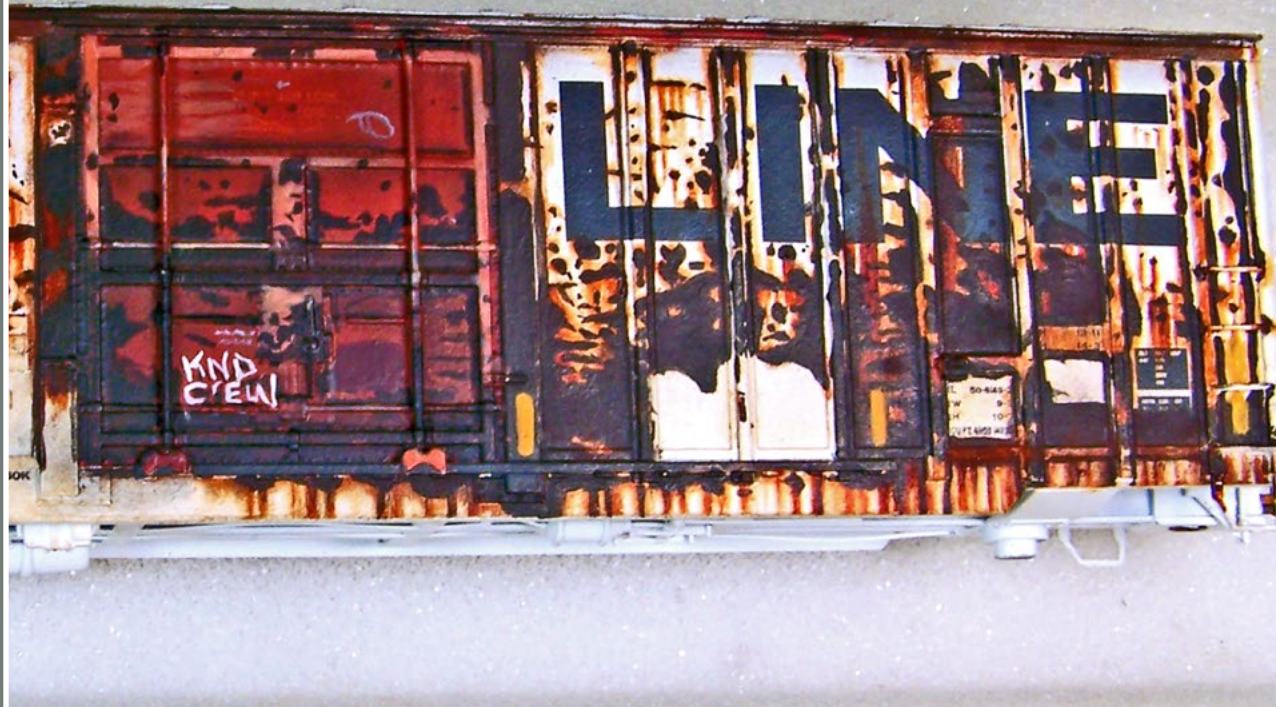

### 16. The completed rust on the car.

With the door weathering complete, I continue to weather the remaining areas of the model. I paint each streak emanating from various rust pits, and bleeding streaks under the door tracks. This is done in another separate session that falls under the category of “fine tuning the weathering.” Now you can see at least one side of this car's weathering job is nearing completion. And as the entire weathering of this side of the car is finished, another misting of Dullcote seals the work.



## STEP 8: Adding graffiti

17



17. The graffiti added to the left side of the car.

Here, in a separate nine-hour session, I added the hand-painted graffiti, COTS label, data, lube plates, etc., to the model and called this one side complete.

18



18. Graffiti added to the right side of the car.



contents



index

## STEP 9: Beginning the roof

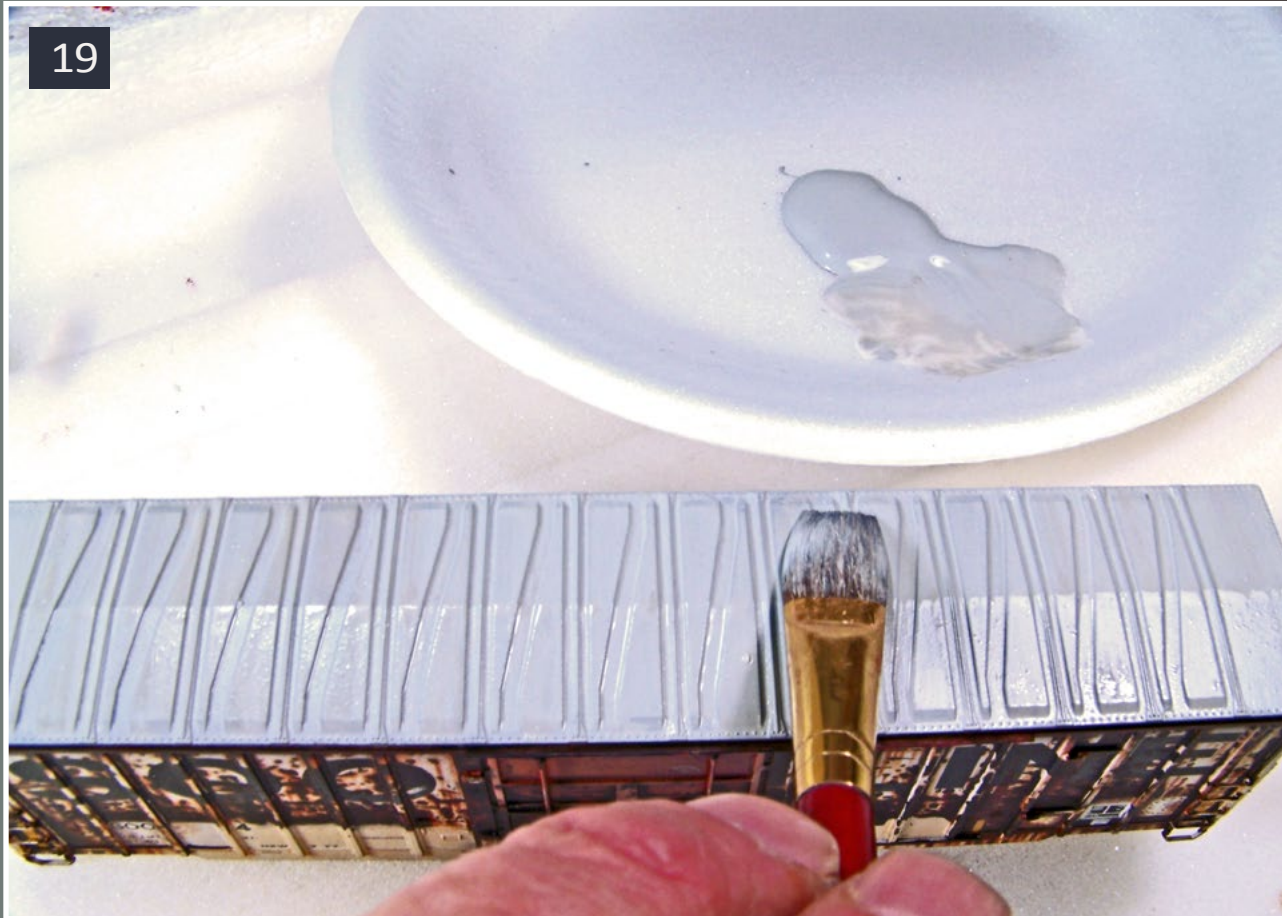

**19. Paint acrylic Bridgeport Gray to serve as a galvanized roof surface.**

I work in sessions, and the roof is its own session. Weathering boxcar roofs is probably the easiest to do and actually is more relaxed. I always prepare a boxcar roof with a shot of the obligatory Dullcote. Once dry, I brush on a slightly thinned Bridgeport Gray acrylic craft paint to represent a galvanized roof, then another sealing with Dullcote before the next step.

## STEP 10: Weathering the roof

20

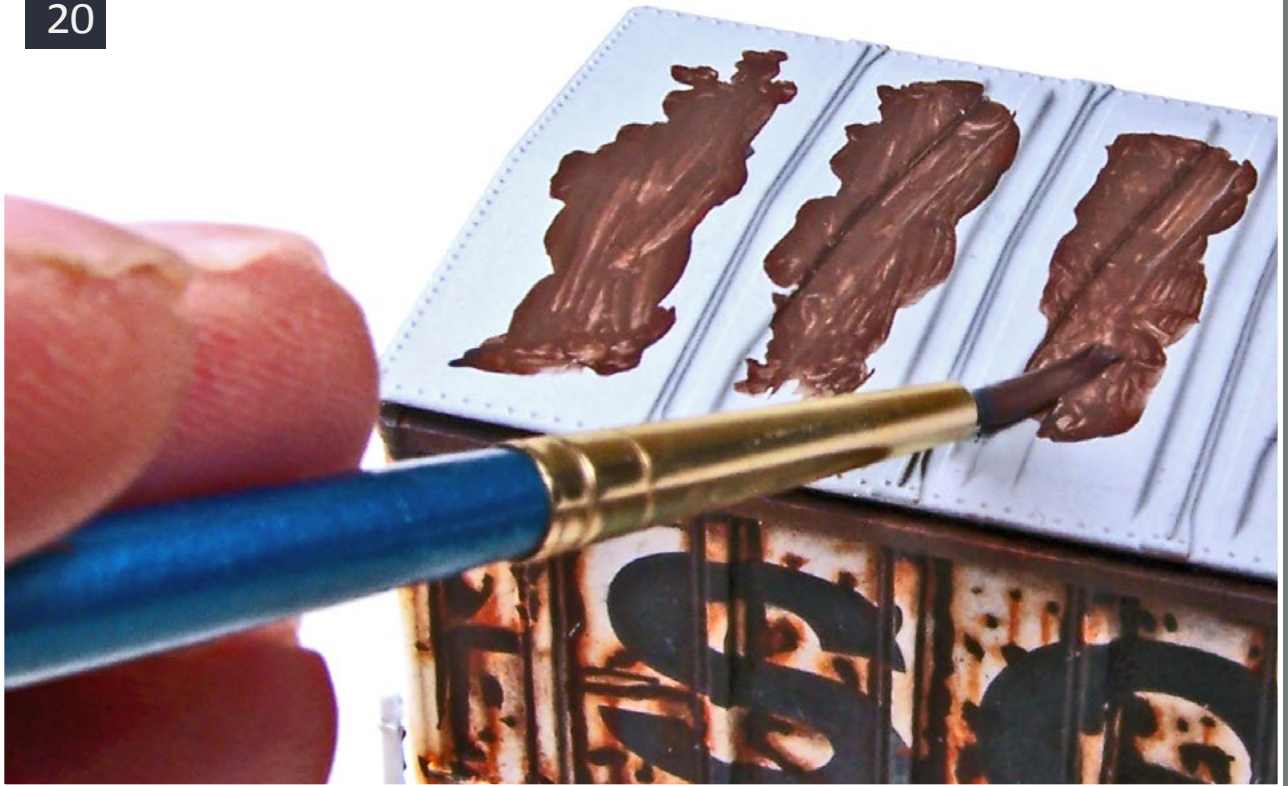

20. I paint the roof rust in the same manner as the sides of the car.



contents



index

## STEP 10: Weathering the roof *Continued ...*

21



21. After a secondary coat of paint and a sealing with Dullcote, the roof is now ready for a halo effect.

## STEP 10: Weathering the roof *Continued ...*

22



22. The halo on the roof rust is complete.



contents



index

## STEP 11: Weathering the ends

23

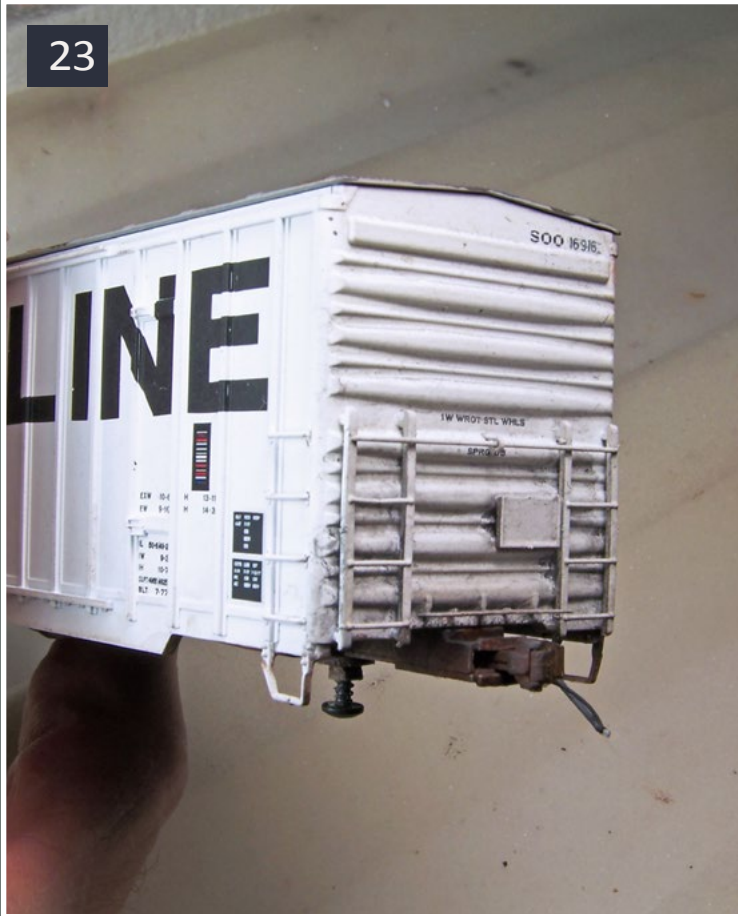

23. The car ends are prepped with Dullcote, and ready for weathering. The grime has been added simulating the typical road dust on the ends of cars.

paint to add the halo effect. This pretty much completes the roof. Once in a while, I dry-brush a light layer of a dark-gray pastel powder for a burnished rust look.

As on the boxcar sides, I paint the dark rust patterns so typical on prototype boxcar roofs exposed to the elements. I use the same colors used to create the rust pits and scratches on the sides of the boxcar – burnt sienna and black acrylic. When all of the rust patterns between the weatherized seams have been hand-painted in multiple coats, I applied a mist of Dullcote. Next I use the Graham & Co. “Transparent Orange Oxide” oil

## STEP 11: Weathering the ends *Continued ...*

24



24. The ends received the same treatment as the car sides.

25. The finished A end.

25



contents



index

## STEP 11: Weathering the undercarriage

26



26. For me, weathering a boxcar undercarriage is a 10-minute job. I mask the sides and ends of the model and then spray the undercarriage with Rustoleum flat brown primer. I then mist a beige camouflage-colored flat enamel to

represent mud kick-up and dust that normally adheres to prototype freight car undercarriages. Ten minutes and it is done.

27



27. I use Rustoleum paint for the undercarriage. Nothing fancy, just the cheap stuff.



## STEP 12: Weathering the trucks

28

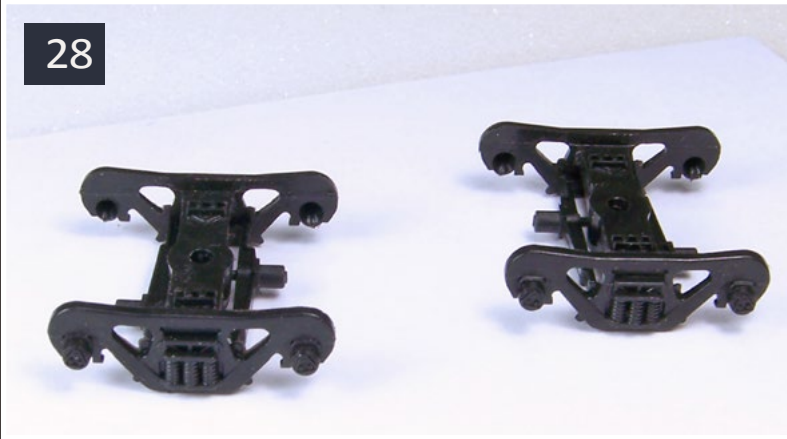

28. Here are the trucks as they come from the manufacturer. I take the wheelsets out of the trucks so I can weather them separately.

29



29. Trucks and wheelsets are another 10-minute weathering effort. I spray the trucks and wheel faces (treads masked) with the same brown Rustoleum primer. I use a chopstick to hold the trucks in place while painting them.



contents



index

## STEP 12: Weathering the trucks *Continued ...*

30



30. I use Iron Oxide or Burnt Senna oil paint to highlight the sides of the trucks.

31. After the paint is dry, I dry-brush Burnt Sienna oil paint and add a mix of brown and orange pastel powder directly onto the wet paint. This gives a very dry-looking rust, and when sealed with Dullcote, it retains that look. I do the same with the wheel faces.

31

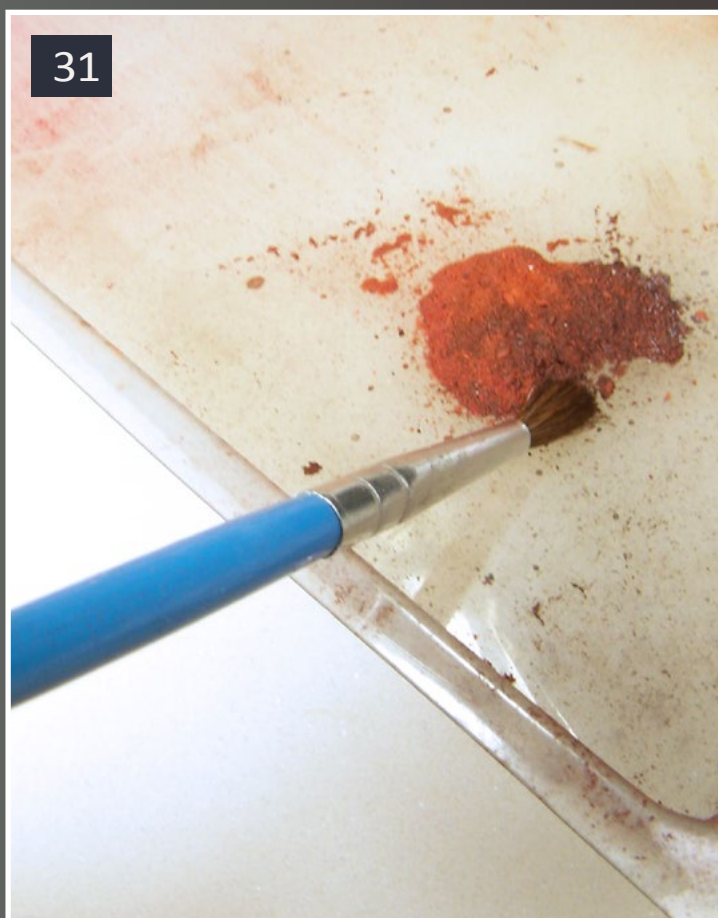

## STEP 12: Weathering the trucks *Continued ...*

32



32. A final spray of Dullcote and the truck is ready. All that is left is to add the wheelsets, mount the trucks to the car, and put it on the layout.



contents



index



**33. 16916 sits on the main waiting its turn to be switched out of the train. The runoff from last night's rain is still standing, creating a nice mirror effect.**

Those are the basic 12 steps I used to replicate a Soo Line rust-bucket boxcar. Here is no. 16916 in all of its decrepit and corroding state.

All-in-all I have approximately 52 hours wrapped up in numerous sessions on this car. All the weathering was done without the use of an airbrush, using inexpensive art supplies. A nicely weathered model can be achieved with cheap acrylic craft paints, inexpensive brushes, and pastels. It is very easy achieve a believable representation of a prototype model without draining one's bank account. All it takes is a little time.

Additional images of this Soo Line model and galleries of my additional works can be viewed at:

[theweatheringshop.com](http://theweatheringshop.com). 



contents



index



Gary Christensen lives in Coos Bay, OR with his wife Andrea of 12 years, and four children. He is employed as a teamster in a wholesale food commodities warehouse. When he is not working, he spends time with his family and at his studio workbench weathering HO scale model trains.

Gary has been an avid railroad fan since youth and has done art work as far back as he can recall. About 15 years ago, two of his interests merged

into what is currently known as model train weathering. He remained “underground” for quite a few years, learning what he could by exploring the Internet on the subject, refining and honing his skills. Finally he joined a forum pertaining to the hobby of weathering called MTW. From there, He met Jeremy St. Peter, who became a close friend.

The two subsequently left MTW and created a website of their own. Jeremy and Gary are the brains behind The Weathering Shop [theweatheringshop.com](http://theweatheringshop.com). It is a collective gallery of what they consider to be some of the very best weathering in model railroading. The site has been online, providing new weekly updates of models, to its members for nearly five years. Since its innovation, Gary has provided a model a month, and to this day he adheres to this agenda.

# Model Railroad Hobbyist *Store*

We **KNOW** how to do digital well!

Mike Confalone, editor of "Railroad Explorer", says,  
"Absolutely spectacular ... it's beyond impressive."

Compare:



200% zoom: "other guys"  
digital book, \$10.95



200% zoom: MRH  
digital book, \$5.99

**Get both digital issues of Railroad  
Explorer for a special price ...**



~~\$11.98~~

\$9.99

**Get them both  
and save**

Seeing is believing: Eastern diesel era prototypes



# Yes, it's a model

**Model Railroad Hobbyist's  
monthly photo album**

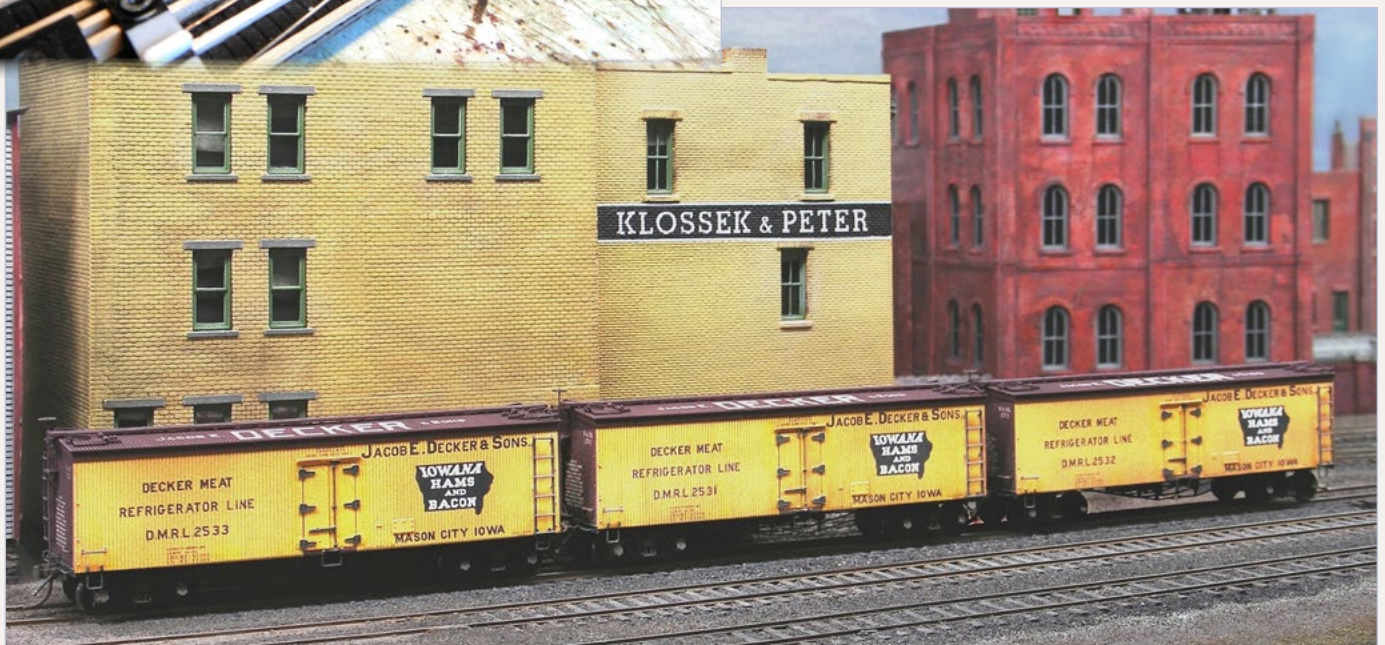

1. It's 1900 and three Decker Meat cars are waiting to be spotted at the local cold storage facility in town.

The cars are Atlas 36-foot reefers that Bernhard Schroeter modified by back dating to K brakes, new handbrake staff and wheel, four new truss rods with turnbuckles, stirrups, and lowering the cars 0.05" to get them to the correct height. To see more of his work go to [model-railroad-hobbyist.com/blog/20899](http://model-railroad-hobbyist.com/blog/20899).







2. Chris S posted this shot of an early 1900s train. The sepia photo calls to mind days past when postcards of trains were a common item. Just add a railroad name and location to the bottom of the card, and most folks won't know the difference.

3. Glenwood & Black Creek Extra 375 along with another locomotive is working up the 2 percent Crested Butte branch near Eagle Rock.

The HOn3 locomotive is an old Westside Model Company outside-frame C-25 Consolidation updated with a Loco-Doc drive and a Tsunami sound decoder. Jim Vail took the photo on his layout.



**Reader  
Feedback**  
(click here)



contents



index





contents



index



4. It is early morning and our photographer captured this photo of Soo 316 heading a local across the trestle as an early commuter drives to work.



On another day he captured Rock Island 4166 and two EMD FB units heading over the same bridge. The morning sun has not yet burned off the fog that settled in last night.

Bob Rivard captured a look and feel with these photos that we think are outstanding.



5. It must be a holiday on Joey Ricard's excellent On2 layout. The flag is flying in Salty Fork, but no one seems to be moving around. We must compliment Joey on how well he's integrated his photo backdrop into the 3D scenery in front. Nice job!

**When talking to  
hobby vendors,  
please remember  
to mention MRH.**



contents



index



6. It is a busy day at 30th Street Station as passengers eat in the food court while others wait for their trains.

Roy Hoffman built this S scale station for his layout based on the Pennsylvania's 30th St Station in Philadelphia. He spent many lunch hours sketching the exterior and interior to build the model. Other modelers gave him the idea to keep one end of the model open so the interior is easily viewed.





7. Mike, why don't you make your wheels shiny like the prototype? Mike Cawdrey of Queensland, Australia posted this picture in Weekly Photo Fun. Great photo, Mike.

## Get your photo here!

Our *Yes, it's a model* monthly photo feature presents some of the most inspiring modeling and photos from the MRH website and other locations. If you'd like to get *your modeling* in our photo feature, just start posting your photos on the MRH website, especially in the Weekend Photo Fun thread created each weekend.

Many of the photos posted show HO modeling, but we encourage modelers in other scales to post on the MRH website as well. We don't want this to just be an HO photo feature!

For info on how to post photos to our website, [see this help how-to](#). You need to be an MRH subscriber to post photos to our website, and becoming a subscriber is free, [just fill out this form here](#).

 **Reader Feedback**   
(click here)



contents



index

# BUILDING YOUR FIRST *resin house car*

– by Rob McLear  
Photos by the author

Small manufacturers' products fill  
gaps in the market ...



1



1. When you open the  
box, this is what you see.





**I**s there a car on your want list that isn't available, and doesn't seem to be on plastic manufacturers' to-do list? The answer may come from one of the resin car manufacturers, who make a variety of car types. Some mold the main body of the car in one piece, and if you are just starting out, then one of these kits is a good starting point. They are considerably easier to put together. If the car you want does not have a one-piece body, then you will have to assemble the body yourself. Most resin kits come with the sides and ends of the body cast as separate pieces. The roof in this kit is two halves to be mated together.

I found myself wanting a Swift Meat Company refrigerator car. Luckily for me, Sunshine Models makes a resin kit of this car and I managed to pick one up. It is their kit number 24.23 for a 2500 series car with the straight black lettering paint scheme appropriate for my 1947 era.

The tools you will need to assemble the kit are common, and should already be part of your tool kit. You will need a large flat file, jewelers small files, hobby knife with a number of blades, and drill bits numbers 80 to 74. You will also need a scale ruler, small machinists square, canopy glue, sanding sticks or an assortment of various grit papers. Assembly is mostly done with CA superglue. You need a quality brand. I use Microscale Thin and Medium consistencies. You will also need wet and dry abrasive paper. I use 280 grit. It is fast and removes unwanted material fairly quickly. Some .010", .012" and .015" brass wire is good to have, as well as .010", .020", .040" styrene sheet, and .010" x .020" and .100" x .040" styrene strip.

These resin kits are craftsman kits. They are not like the normal plastic ready-to-run car or even a plastic kit. There are no painted pieces and it all looks rather daunting. It really isn't so



contents



index

difficult to build. It is just a matter of taking your time and proceeding in a methodical way.

## What's in the box?

There are instructions and a history of the prototype car. In Sunshine kits the history can be quite extensive and detailed, as it is with many resin kits. There are bags of assorted parts, ladders, grab irons, stirrup steps, roof grabs, wire, and decals. The heart of the kit are the resin pieces.

As you can see [3], a lot of parts need to have the flash removed. In this kit the flash is not too thick, and the parts are

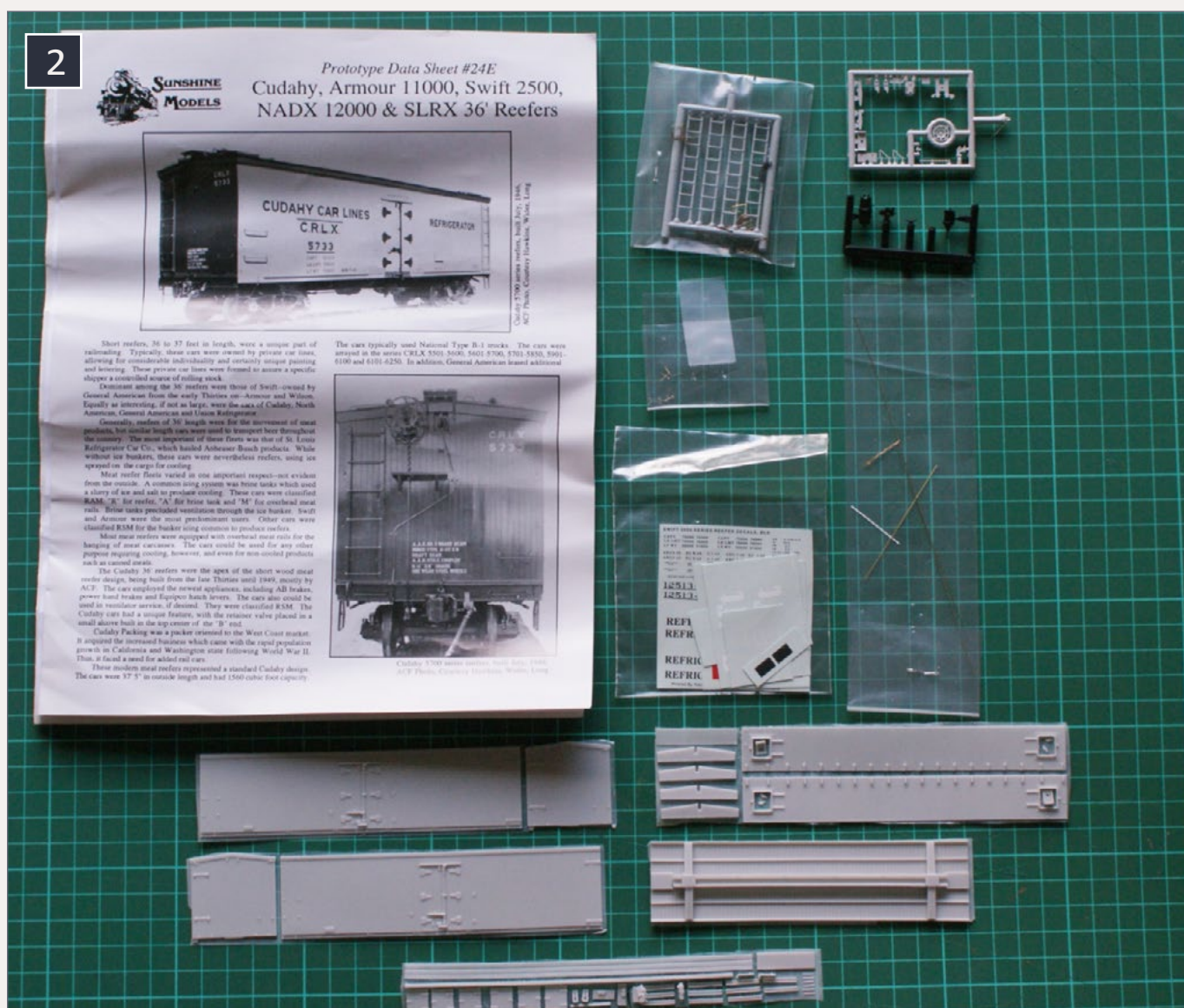

## 2. The various parts laid out.



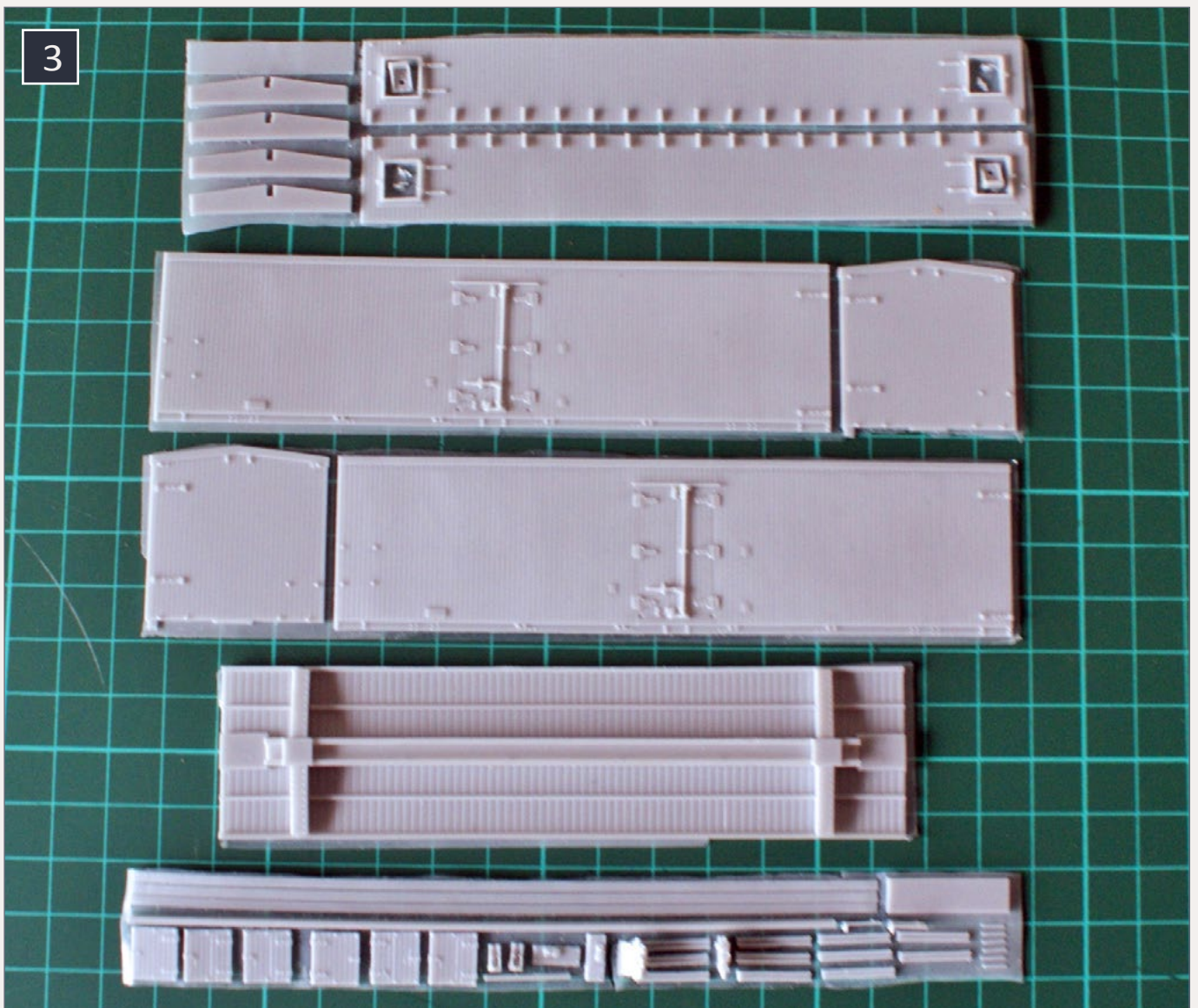

### 3. All of the resin parts that need to have casting flash removed.

fairly easy to remove. There are two ways you can do this, but you will need to have a piece of glass to work on. Glass is flat and true and is a valuable tool for removing flash. For clarity I have taken the pictures on a green cutting mat, not on the glass, so the camera can pick up the detail.

One way to remove flash is to lightly sand away the excess resin with a piece of wet and dry abrasive paper. Work with the sandpaper face up on the glass plate. Hold the part with its back side down, and gently move the part side to side until the flash drops away from the edges. Check your work often to be



contents



index

sure that you are not applying too much pressure to one side or end. I use this method to clean up the very fine small parts that are in the kit. The most important thing to remember is to check often and take your time.

I cut the flash away from the bigger parts with a hobby knife. The flash on this kit is very thin and fine. I make sure I have a sharp blade and replace it a couple of times. Resin dulls blades very quickly. Once the flash is removed, I gently run a file along the edges to true them up and ensure they are square. I take my time since this step is important. Any mistakes here can affect the assembly and look of the car later. I use a large mill file for this. I find that it has a very flat and true surface. Some of the smaller hobby files can cause you to wander. Try not round off the corners of the car. If you do, it can be fixed, but it is better not to.

After using the file, sand the back of the part lightly to remove the glossy surface and help the glue grab on to the

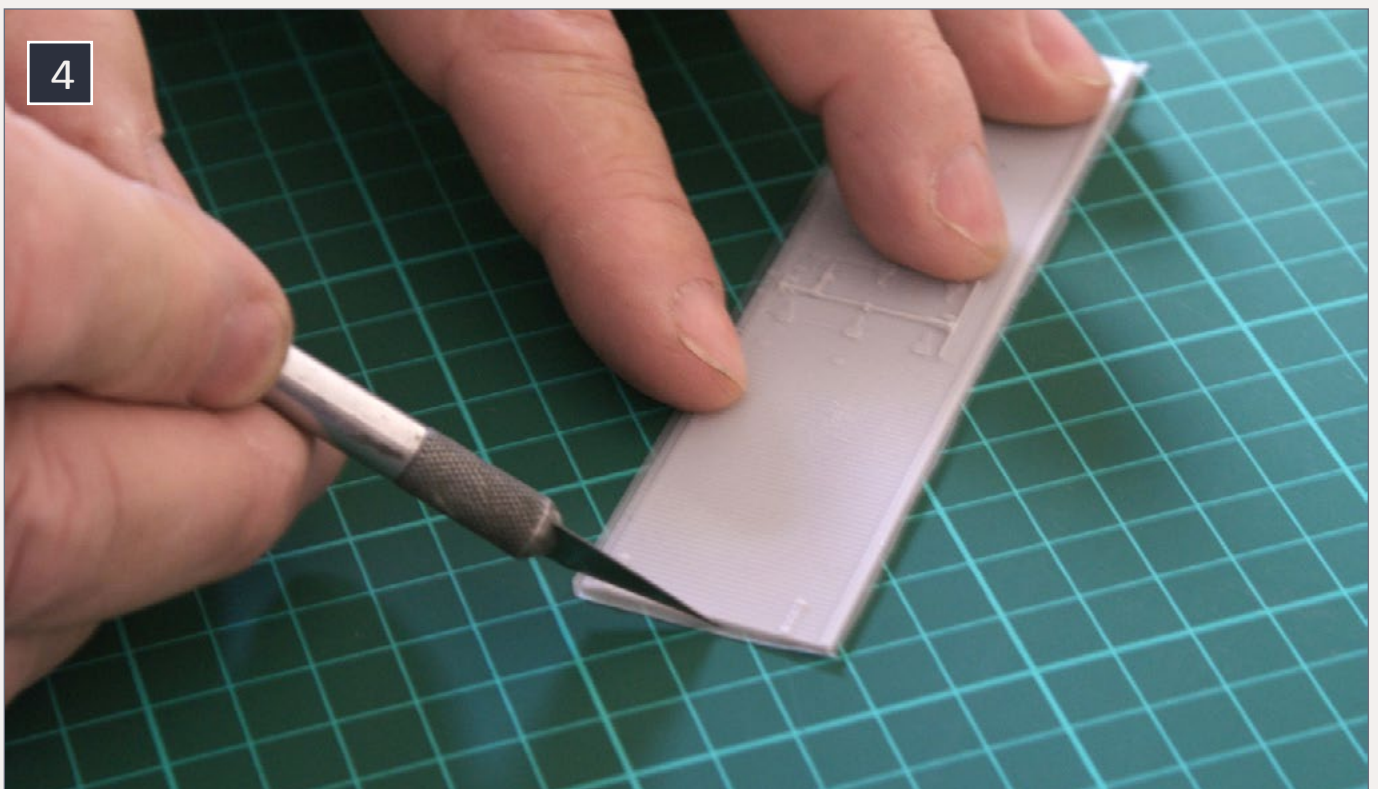

#### **4. Remove flash from the parts with a hobby knife.**

5

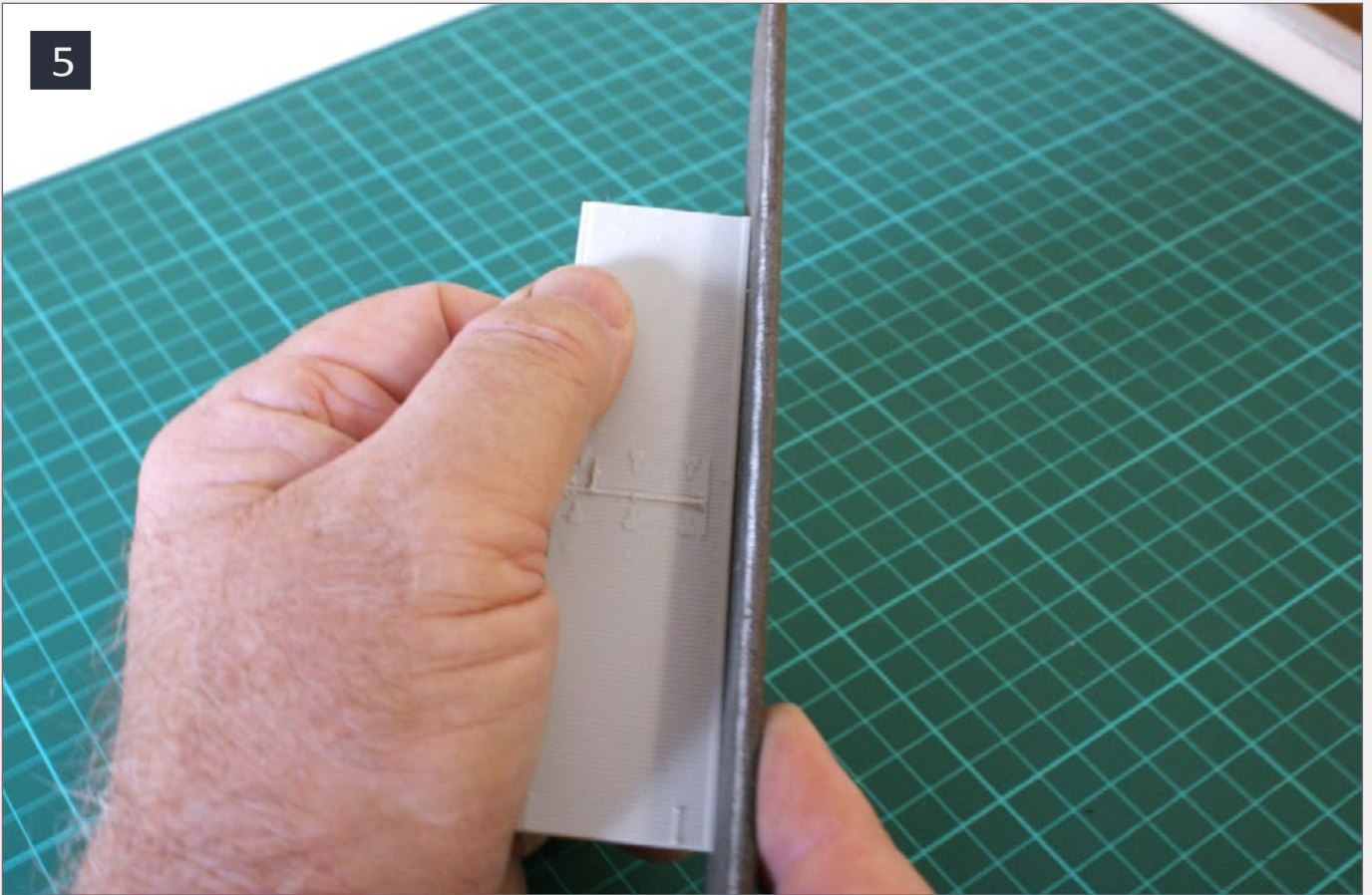

## 5. True up the sides with a large file.

part. There only needs to be some “tooth” on the back of the part to be effective. Once all the parts are cleaned up, this [6] is what you have.

With this kit there are six ice hatches, but you only need four for the car. Most resin manufacturers include spare parts. This helps if you make a mistake, or a small piece flies off into Neverland. They are also handy for the spare parts box.

Smaller parts can also be cleaned up by sanding. If I damage one of the smaller parts cleaning it up, I look at how is made. I can sometimes make a new part out of styrene. Check your parts list before throwing out the large amount of excess flash and resin dust. You may throw out a very small part you will need later. Ask me how I know!



contents



index

## How to assemble the kit

Before starting assembly, check the sides for length and height. They should match exactly. Mine were the same height but not the same length. I carefully sanded the longer side until the two sides were the same length. It is essential that the ends and sides match each other. If they don't, the model will be out of square and the underframe or the roof will not fit without gaps. Resin can sometimes shrink in the molding process and it is not unusual for parts to be different sizes.

Now it is time to do some assembly. Read the instructions before starting. Sometimes there are hidden treasures for you to find. Familiarize yourself with the assembly sequence. For this kit, after reading the instructions I changed the sequence.

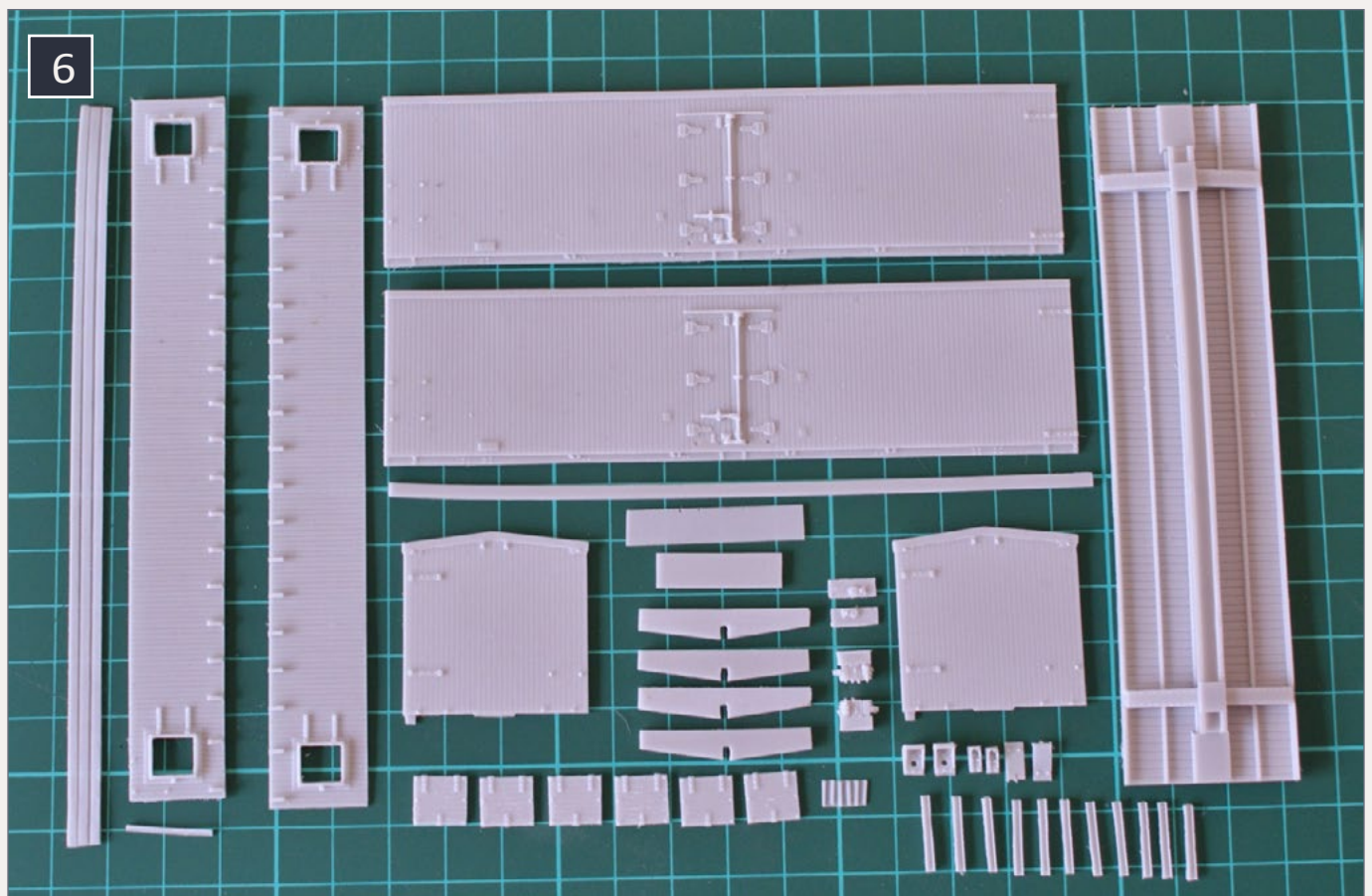

**6. All of the resin parts with flash removed and ready for assembly.**

7

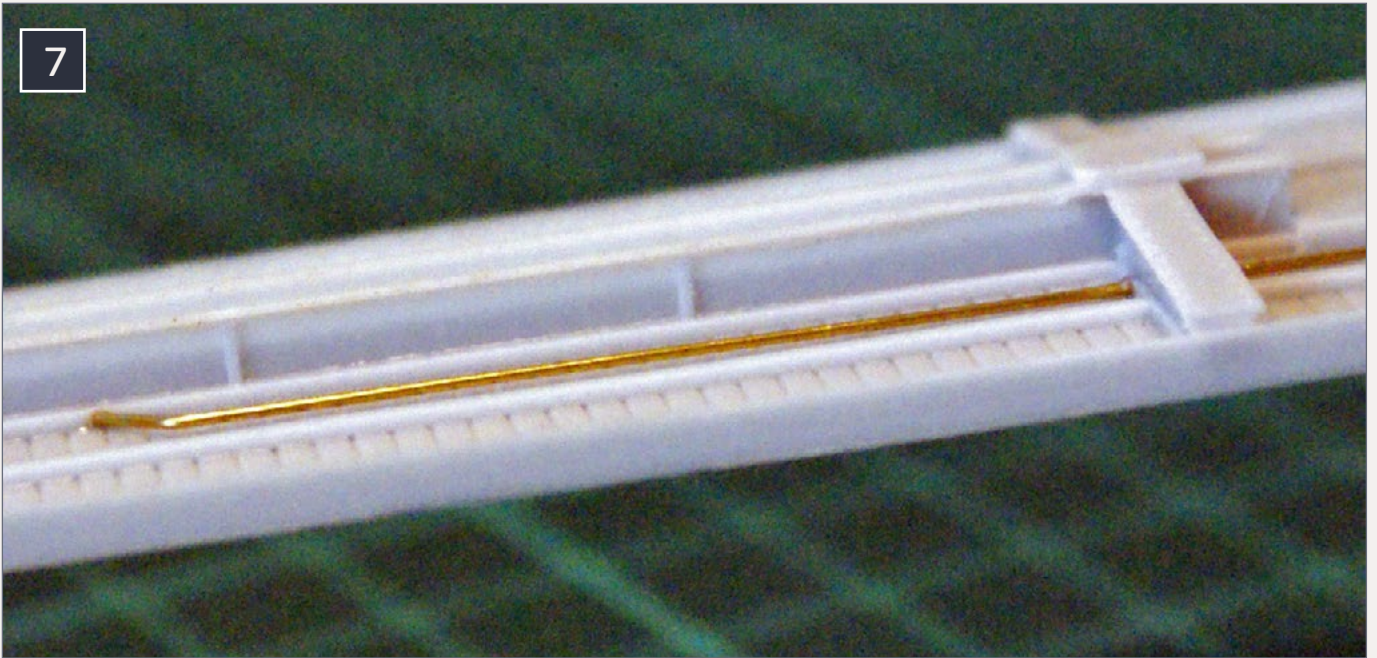

## 7. Train line attached to the underframe.

The instructions call for painting the sides, ends, roof and underframe before assembling the basic box. I find this hard to do as it is practically impossible to clean up glue spills on a painted surface.

Begin with the underframe. This includes all of the brake parts and stringers. Eight stringers are required. If you want to add the train line for the brakes, do it now before installing the stringers. The instructions on this kit did not call for a train line, but I like to add it. I use .015" brass wire to represent the train line and drill through both bolsters [7] with a size 74 drill for a tight fit. TIP: Drill a small distance into the center of the car at the angle so that the wire can be seated in the channel.

In [8] you can see a stringer ready to be attached to a vertical rib. Before doing so, file a small indent into one end of the stringer to help them to seat properly.

Now for the brake parts. I followed the instructions here and added the brake reservoir, valve and brake cylinder with the



contents



index

associated piping. If you are unsure of how all of these parts go together, there is an excellent article by Ted Culotta in his Essential Freight Car Series in the August and September 2003 issues of *Railroad Model Craftsman* that shows both AB brake and K brake assembly.

Drill the holes for all of the brake lines while the parts are still on the sprue. They will not be accessible after the underframe is assembled. Use a size 78 drill and have at it. There are two holes in the reservoir and four in the triple valve.

The brake cylinder has one hole, in the rear. Also at this time, it is best to drill out the holes in the brake levers. The wire piping between the reservoir and the triple valve is .012", between the triple valve and the cylinder is .010", between the triple valve and the train line is .010".



**8. The stringer ready to be installed.**



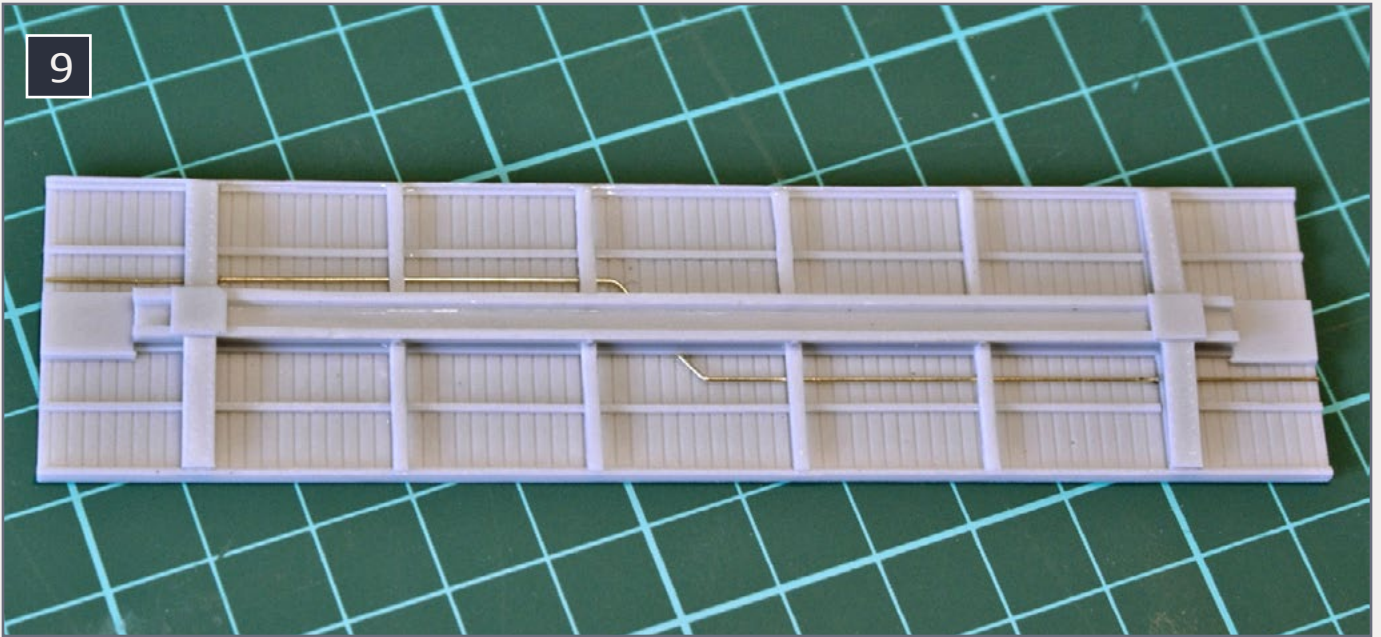

9. The underframe with the train line and stringers installed.

## Finish the underframe

While the Sunshine instructions do not call for it, I also add short lengths of chain between the cylinder and the cylinder actuating brake line from the handbrake.

The easiest way to do this is to open up the end of an eye bolt, slip the chain over it, and close the eye with pliers. Don't try to put it on the eye end. You'll go blind trying. I take the long end and thread it through the chain link just like threading a needle. The other end is some .012" brass wire with a small loop bent into it, then threaded on the same way. It is easier to do [9] than to describe.

To get this line in the underframe, I drill a number 76 hole through the bolster. I make a small inverted "U" holder from .012" brass wire, and place it over the line. Alternatively you can mount the line on the bolster with another eye bolt. I prefer to keep it away from the truck swing and mount the line through the bolster itself. It may not be prototypical, but at



least it is there and not interfering with operation. Add all of the brake piping according to the diagrams in the kit. The brake levers have to be supported by brackets made with grab irons.

**TIP:** Before drilling the holes, cut one of the grab iron legs off a bit shorter than the other, but long enough to insert. Drill a hole for one side of the grab and then see where the other end falls. Mark this position with a pin or needle and drill. This procedure gets the distance right every time. Thanks to fellow freight car modeler Clark Propst for this tip. He has used it on a number of occasions to add car pulling eyes to the sides of freight cars. The idea works just as well for grab irons and loops. The completed underframe with the brake assembly is shown in [10].

## Sides and ends

With the underframe done, it is time to start on the ends and sides. First, add the grab irons to both ends. To help with drilling the holes, I mark the location with a pin to act as a centering point, stopping the bit from wandering and spoiling the part. Again, cut one side of the grab iron short and drill one hole, then line it up with the nut-bolt-washer (NBW) casting on the other side.

If it fits, go ahead and drill and mount the grab iron. If it doesn't fit, you will have to shorten or lengthen the existing grab iron, or make another from wire. Once drilled, insert the grab irons and attach them with CA from behind. After the glue sets, nip off the protruding ends. In [12] you can see both ends with the grabs. I use the .020" styrene spacer to set the grab irons the right distance from the end and sides of the car. Finish the ends with the ladders, trim them to fit, and add the brake details to the B end.

10

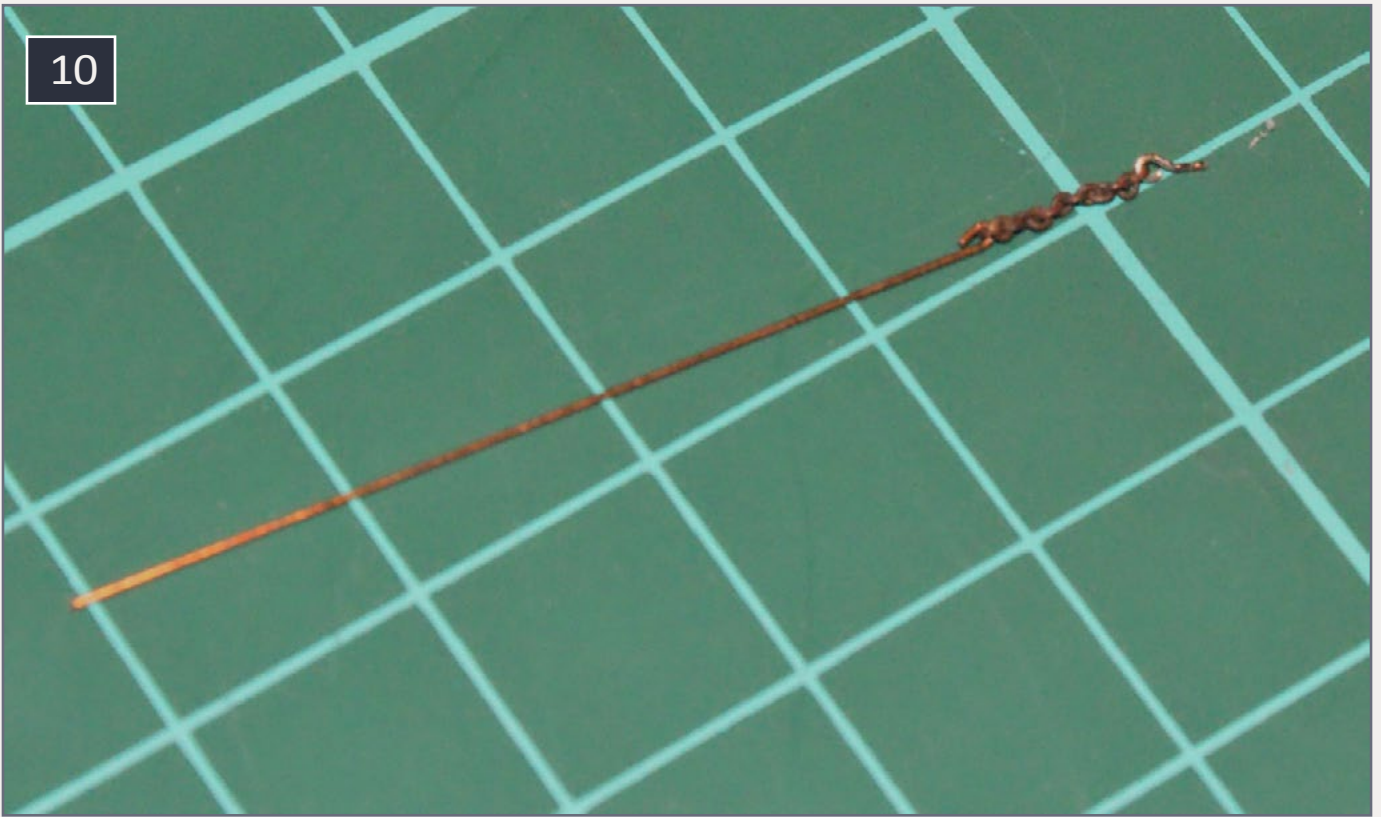

10. Chain attached to brake line.

11

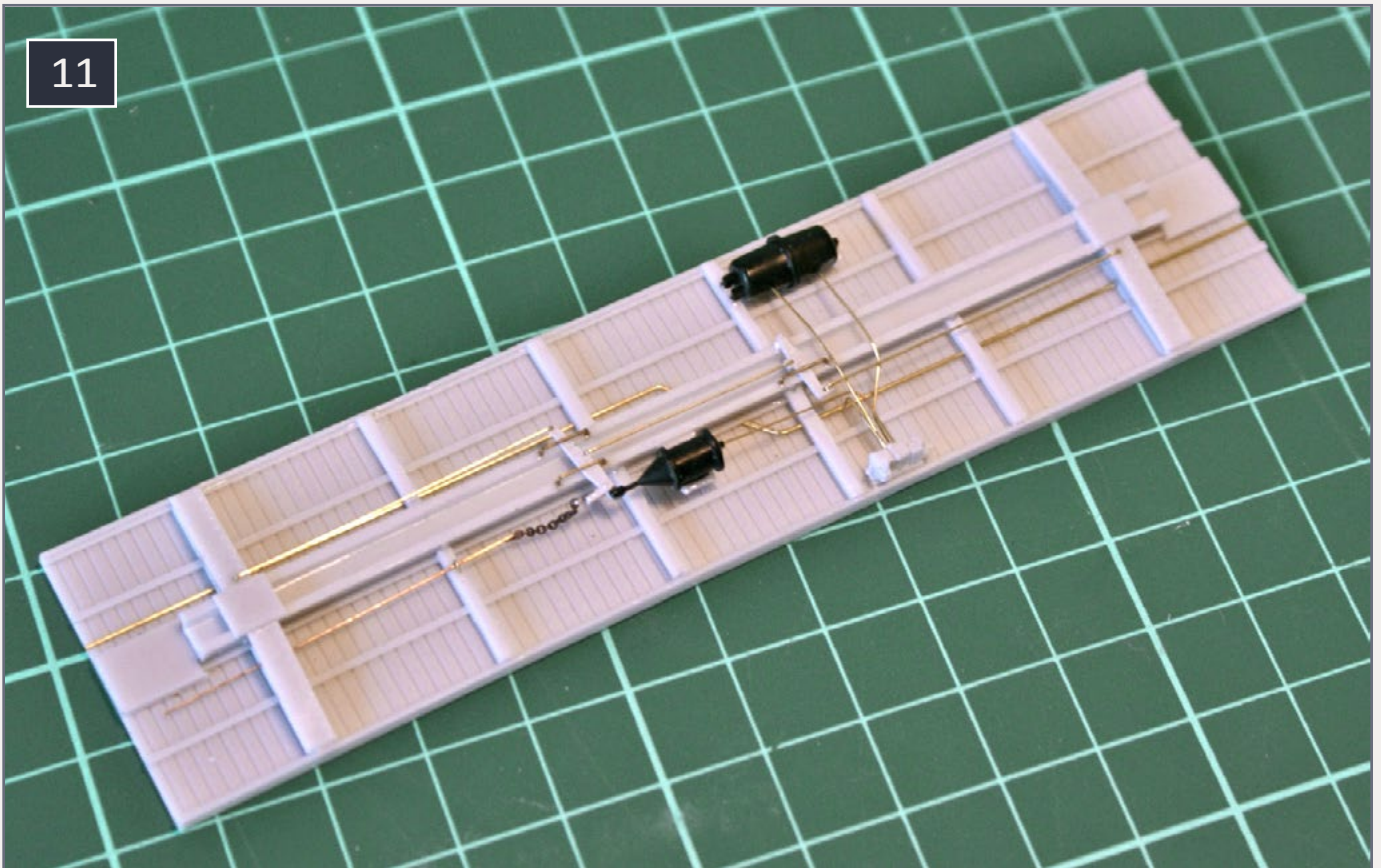

11. The brake valve, reservoir and brake cylinder with piping installed.



contents



index

Now for the sides. The grab irons in this kit were larger than the spacing for them between the nut-bolt-washer details. It was a simple fix to straighten one side and re-bend them to the correct length. Again, mark the holes and mount the grab irons. Now we have the sides, ends and the underframe complete [15]. It's time to make the car into something more recognizable.

## Building the box

How well the car turns out depends on the care taken in this step. If you have all the parts square and true, then this should be a simple assembly step.

**TIP:** The corners where the ends and the sides meet are very small in cross-section, so add square or angled styrene or similar material to strengthen the joint.

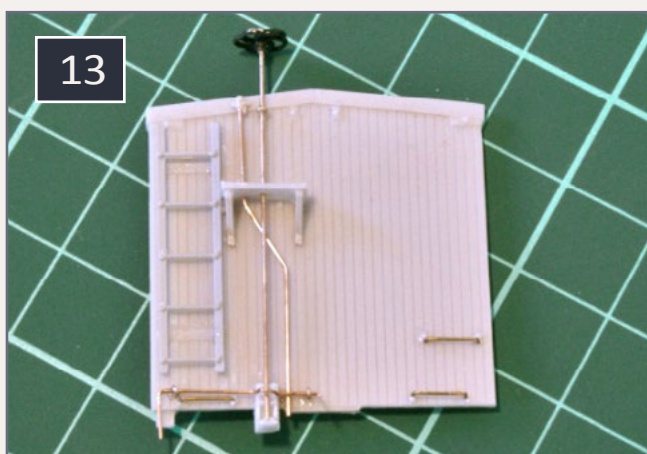
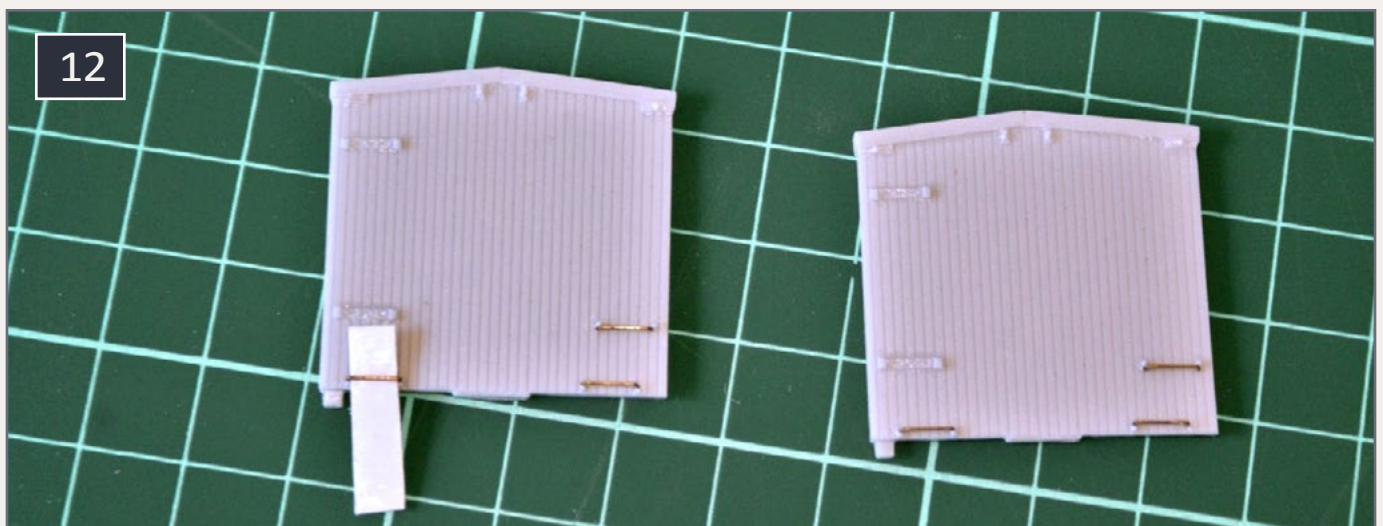

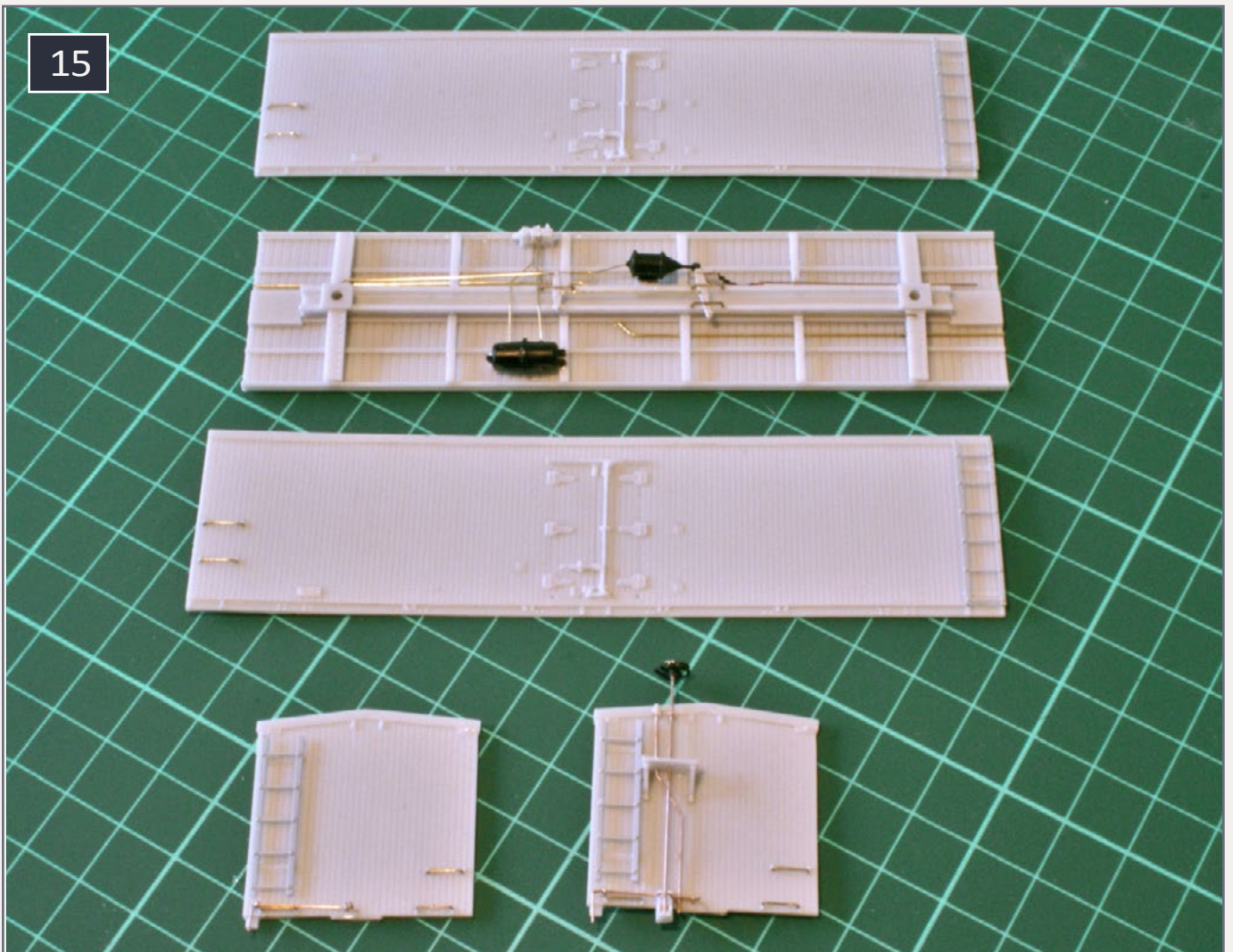

I didn't have any square styrene and used "L" angle instead. This gives more surface area for the glue to grab. Notice that the angle doesn't go all the way to the top or bottom of the side. This is to allow for the underframe and roof bracing to be fitted later. Take your time here and wait for each joint to set up before proceeding.

**12. Installing the grab irons in the ends.**

**13. B end complete.**

**14. The A end complete.**

**15. The underframe, ends, and sides completed and ready for assembly.**



Don't panic if the sides and ends don't fit precisely. Two of mine didn't. That is what body putty is for. I use Squadron Green putty because I am familiar with it from building plastic model kits. Use whatever you feel comfortable with, but remember that some putties shrink on drying. Test the putty on some scrap pieces to make sure that it doesn't attack the resin. Make sure you leave sufficient material to be sanded down.

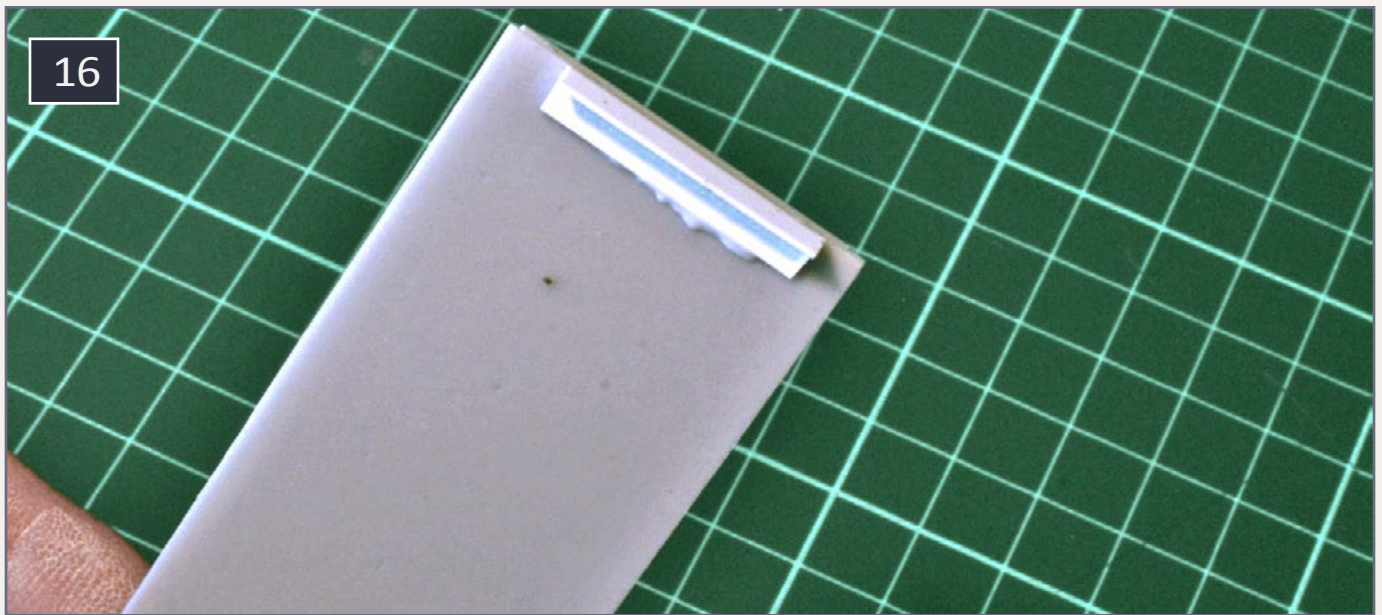

**16. "L" angle installed on one end of the side.**



**17. A end and one side cemented together.**

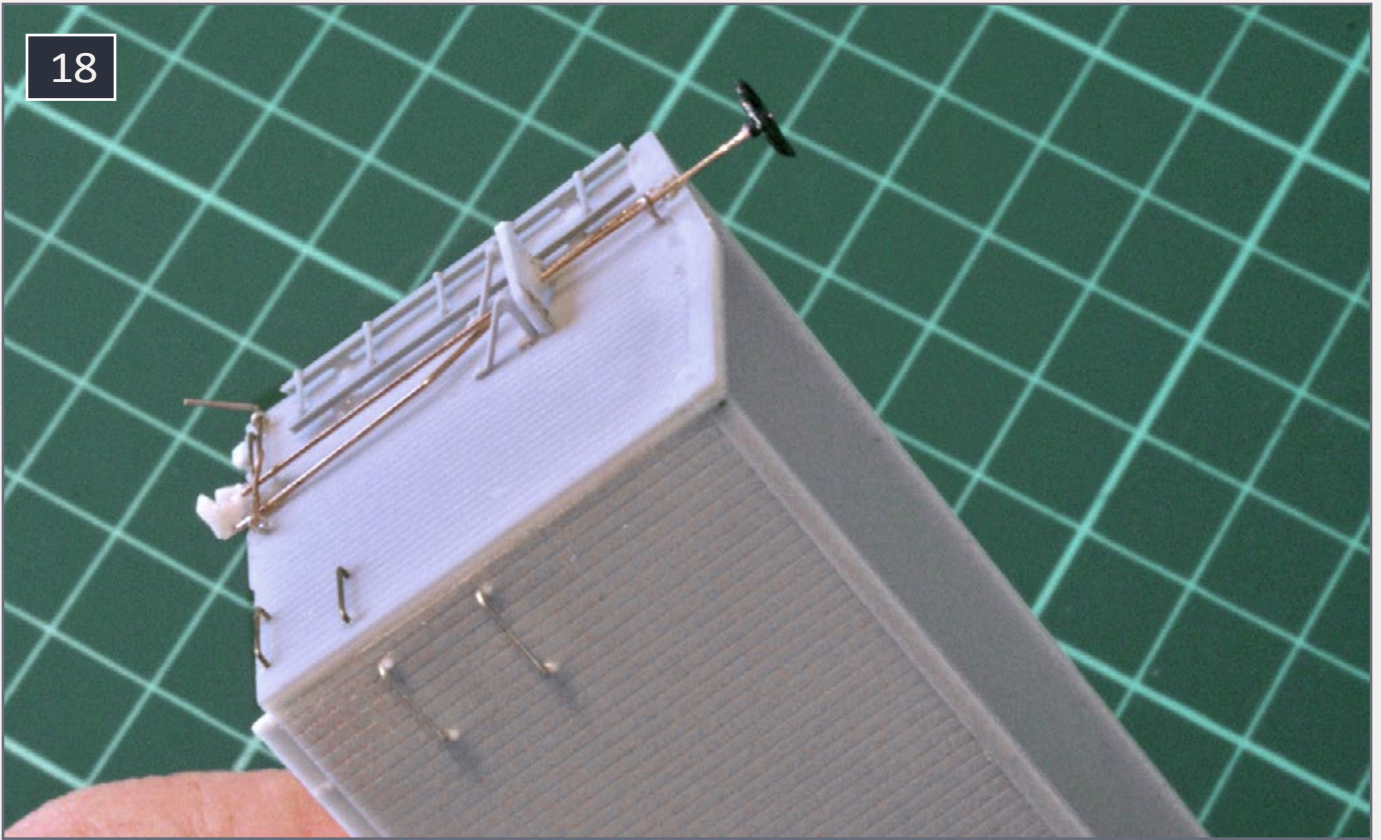

## 18. Filler used at the top of the car to fix gap in join.

You can see what one of the puttied joints looks like when finished [18]. How did this happen? I wasn't careful enough with the file when finishing the parts and rounded off the top corner ever so slightly. When mated with the flat of the end, there was a small gap at the top.

## Add the underframe

Now that we have the box, it's time to mount it to the underframe. Test fit it to make sure the fit is OK. With my kit, the sides were a touch too wide. A few swipes with the flat file fixed the problem. The underframe was also short. At either end the gap was about .020". I fixed this by gluing pieces of .010" styrene to each end so that the bolster and truck center spacing is not affected. If you glue the fix to only one end, your underframe and truck spacing will be wrong.



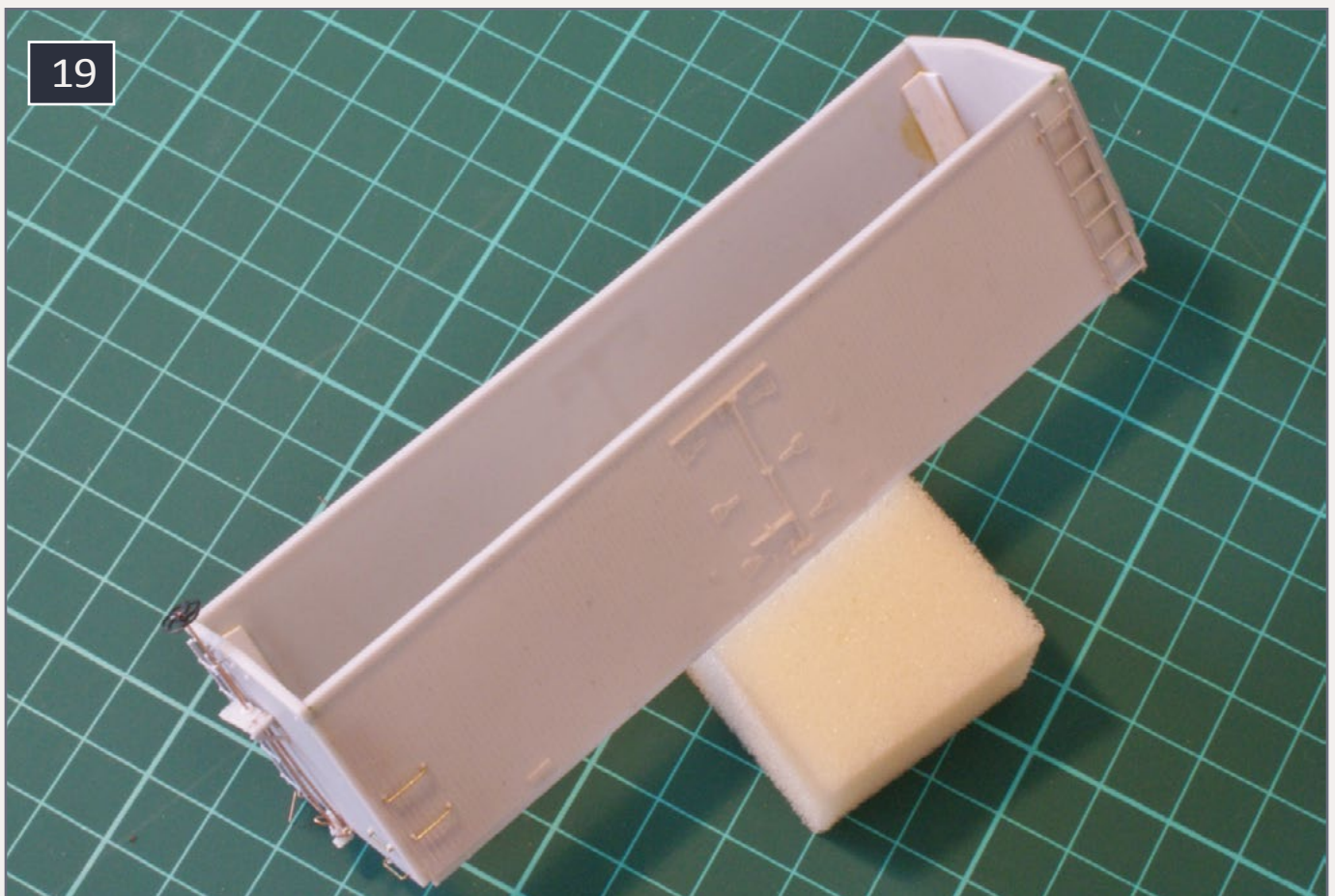

19

**19. The basic car body completed.**



20

**20. Use a styrene shim on the end of the car to center the underframe in the car.**



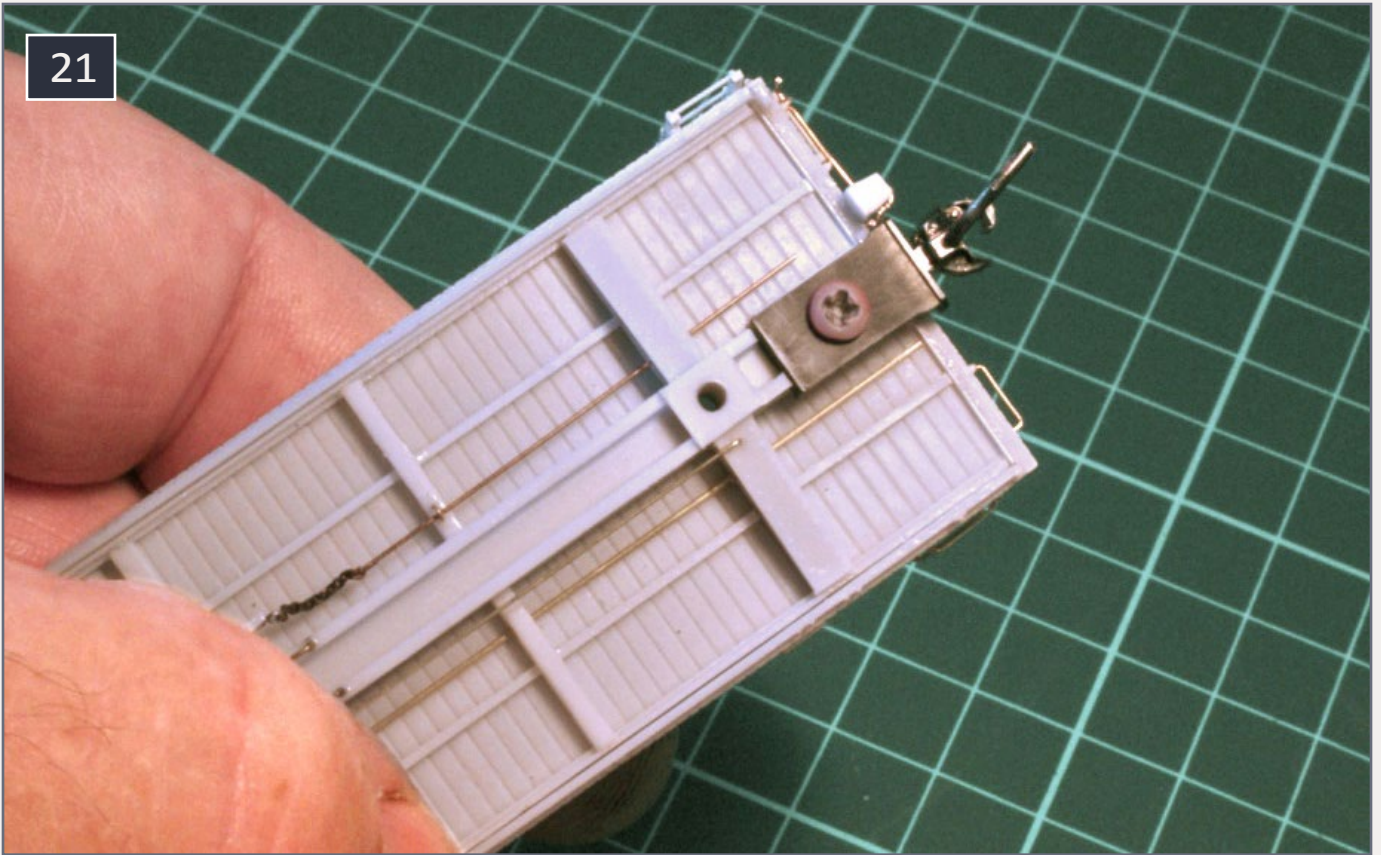

## 21. Couplers installed.

After fitting the underframe, add the couplers. It is easier to do this before the body is attached to the underframe. Be sure to allow for the thickness of the car body's end if it overlaps the underframe.

I use Kadee scale head whisker couplers with a short shank. I cut off a small portion of the center sill between the bolster and the end to make my coupler box fit. You can also see the styrene spacer at the end [21]. I drilled mounting holes for the trucks at the same time as the holes for the couplers. Make sure the truck screw holes are exactly centered on the bolster.

**TIP:** An easy way to center the truck holes is to lightly scribe with the back of a hobby knife crosswise from corner to corner, making an X. This gives you the center as a point to drill. Mark the center with a pin, and away you go. The scribe lines are not seen when done, and they don't interfere with the operation of the truck.



Now glue the underframe to the sides and ends. The easiest way to do this is to glue it from the inside and then set it aside to harden. Once the underframe is mounted, you end up with something looking like [22].

I am not worried about coupler height at this stage, just mounting them correctly on the underframe. These prototype car had Barber Stabilized S1 trucks which are not yet available. I fitted temporary trucks to my car to check the height. It was low but there is no point in adjusting the height until I can get the correct trucks. These should be coming soon from Rapido.

## Weight for performance

It's time to weight the car to NMRA standards. The kit instructions call for 2 ounces. I use tire balancing weights which are lead covered in zinc to enable them to be handled safely. Whatever you use, make sure to center the weight in the car. The completed car, rounding curves, could have a problem with weights off center.

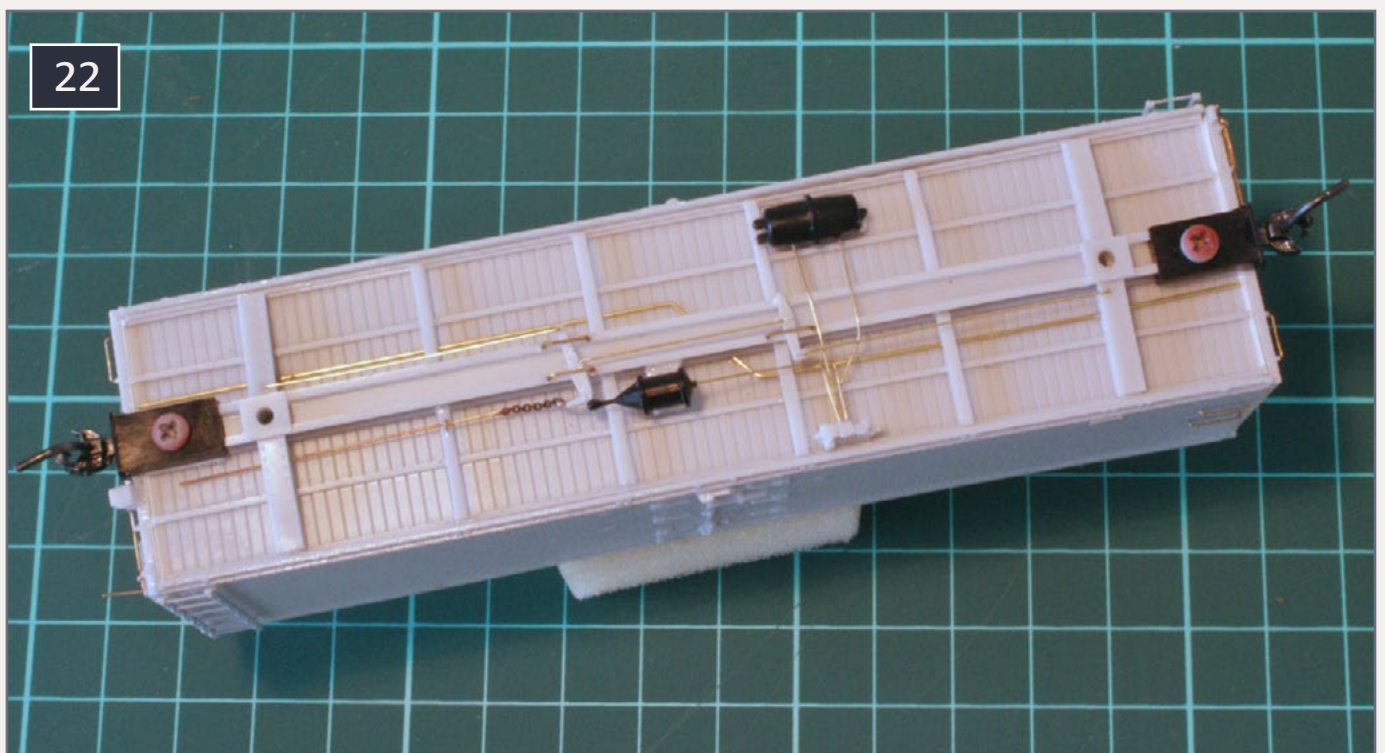

22. The completed underframe installed in the car.

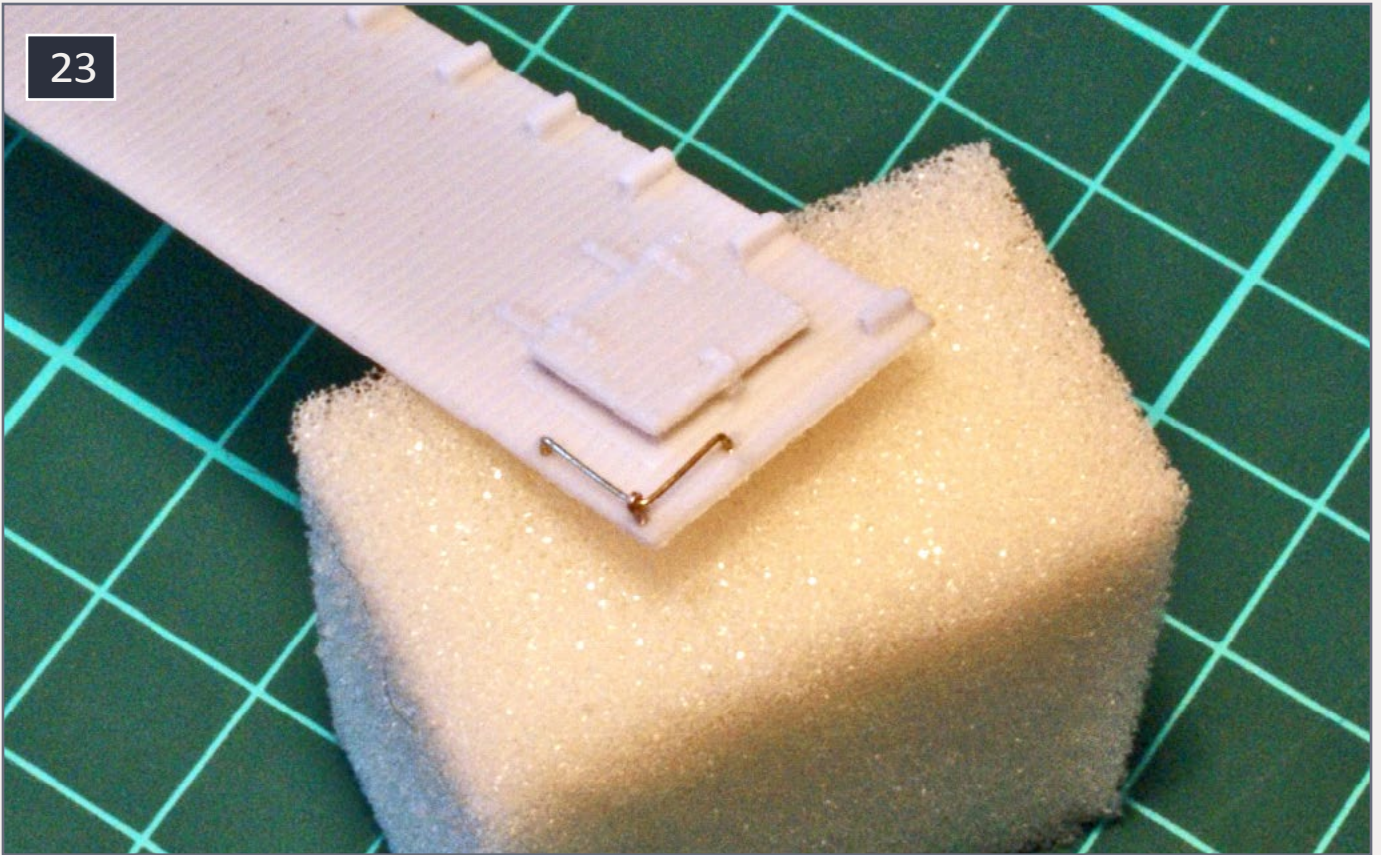

## 23. The corner grab installed on one half of the roof.

Once the car weights are added, move on to the roof assembly. The roof is in three parts. The instructions call for adding the roof hatches next. This would make installing the corner grabs difficult, so I did them first. Use the same method, as the grab irons on the sides and ends, cut one end of the roof grab short, insert the long end, mark where the short ends falls, and drill. Adjust the grab as necessary. Then insert the long end of the grab and add the eye bolt for the center stand. Insert the eye bolt, then insert the short end. Apply CA from underneath and trim the protruding ends for a flat surface. You can see the completed grab, with the ice hatch installed in [23].

## Roof and reinforcements

Remember that the car is going to be handled from time to time. There are roof supports in the kit but they do not provide much help in bracing the sides. It helps to brace the sides



so that they don't flex inward. I add .060" styrene bracing into the kit in three places. Size the braces so that they fit snugly at the end of the car. If they are snug against the end, then they will maintain an even distance between the sides.

Now it is time to install the roof. Add the kit bracing to the ends and between the styrene bracing you have installed. Make sure the angles of the braces match the roof angle. You can see [25] that I have also notched the styrene bracing that I put in. I should have done that before I glued them in.

Included in the kit is a long support brace which slots into the kit-supplied roof braces. I don't often use these but substitute styrene instead. I find the styrene more stable dimensionally and easier to use. In my case, the dimension was .040" X .100". I didn't have a piece of styrene that matched so I just cut a strip off a black .040" sheet. Glue this in, making sure it is level with the apex of the roof guides.

Next glue on the roof, doing one side at a time. I use canopy glue here so that I have some working time. Apply the glue



## 24. Internal baffles or supports installed in the body.

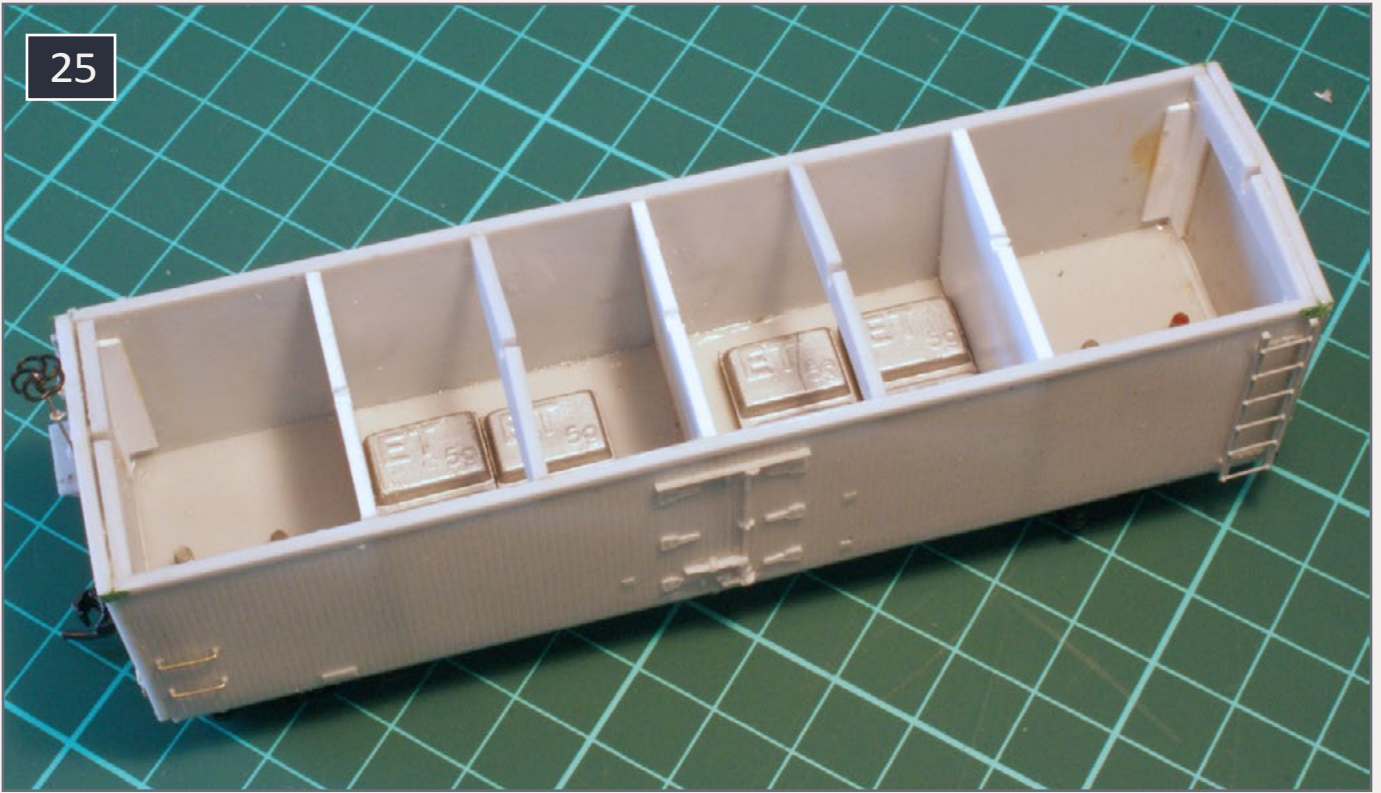

## 25. Baffles notched for the roof support, with the weights installed.

to the other side and install the other half of the roof. Check that you have an even overhang on the sides and ends. This is where the canopy glue is handy; it gives you some working time before it sets up.

### Final check

With the roof on, check for gaps. If you have small gaps as I did, then use some body filler to fill them. Notice that the running board has not been applied yet. I still have to add some detail parts, the running board, and more importantly, the running board supports that can be damaged with handling. I add these last. Don't worry about the gap in the center of the roof. It will be covered by the running board and will not be seen. If you like, you can add some glue to the center of the roof to help secure it.



Now it's time to add the detail parts. All I have left to add are the corner stirrups, and the center stirrup to be secured onto the underframe of the car.

I drill number 72 holes into the underframe as close as I can get to the sides. I have tried drilling into the sides before but find this almost impossible to control. The outside of the underframe has mounting points with two NBW castings molded



26

**26. The center roof brace has been added.**

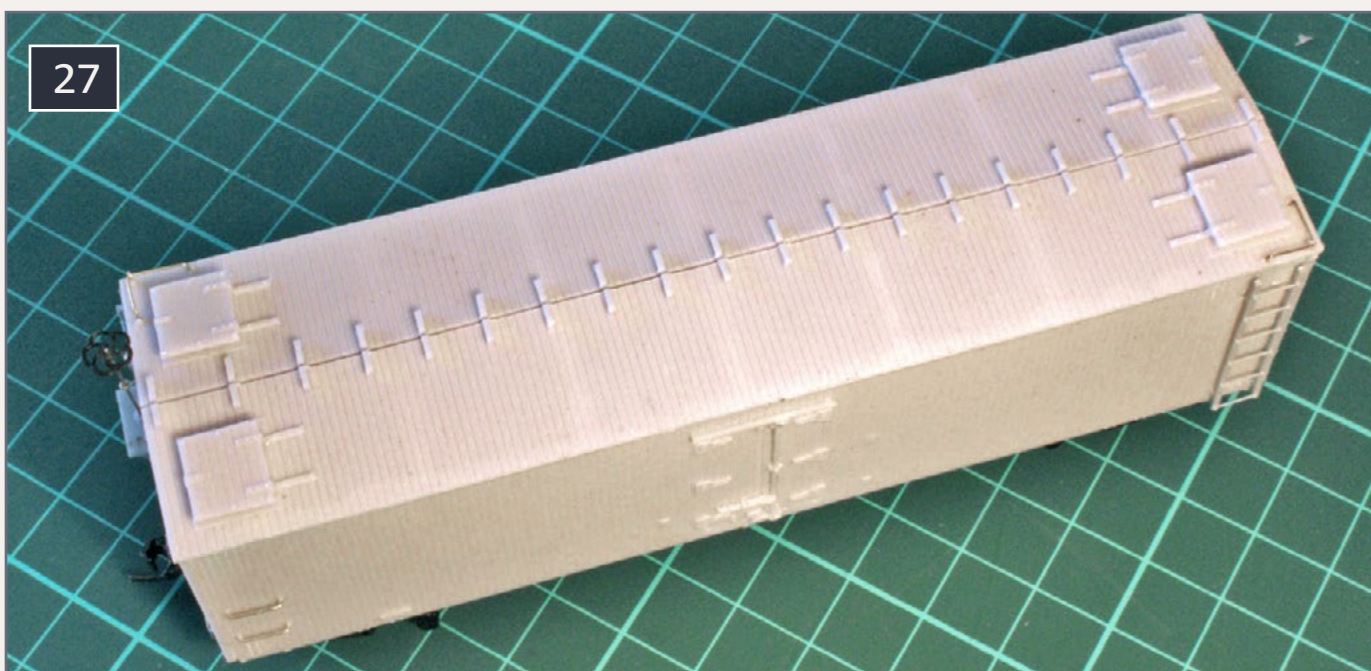

27

**27. The two halves of the roof have been installed.**

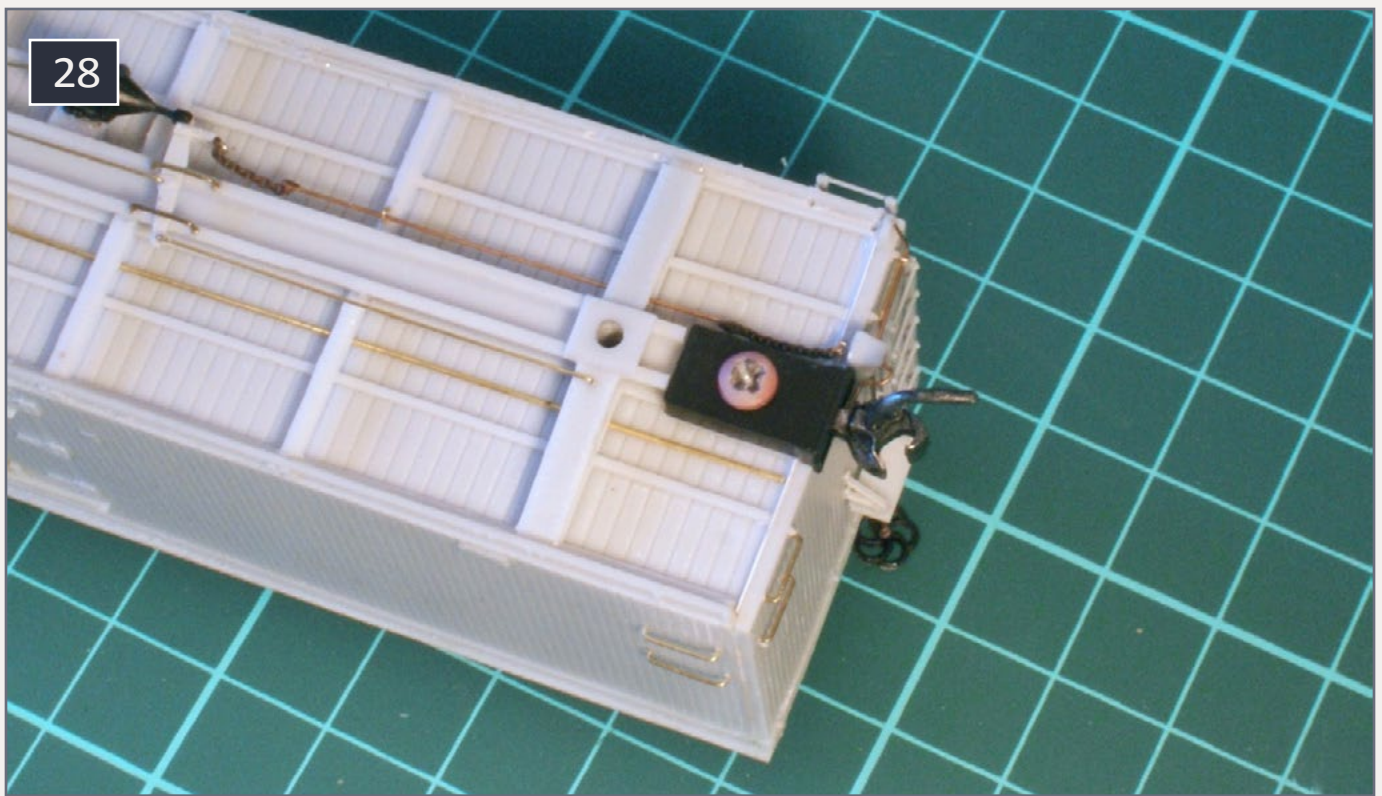

## 28. The holes drilled for the corner steps.

on them. Get as close as you can to these. You can see my attempt in [28]. I had to open up the one closest to the end a bit to make it work.

With the holes drilled, go ahead and attach the stirrups with CA. The parts supplied in the kit look like A-Line stirrups, so if you make a mistake it is easy to get replacements.

To do the rest is just a matter of repeating the processes. Once all of the supports are mounted I add the running board to the car with canopy glue. The glue I used is from Pacer, but there are others around. Fellow modeler Tony Thompson has been extolling the virtues of this glue for some time and now I understand why.

Before mounting the running board, I run the teeth of a razor saw in between the boards to separate them for the first couple of scale feet [31]. It gives the impression that there are



contents



index

separate boards on the ends. Install the bracket for the running board end braces. In the kit, one of the resin parts was a very small “L” shape. Cut this to the width of the running board and mount one on each end.

Then, mount the running board. Check to make sure all of the mounting points on the roof are level and even. I needed to swipe mine a couple of times with a file to get the tops even.

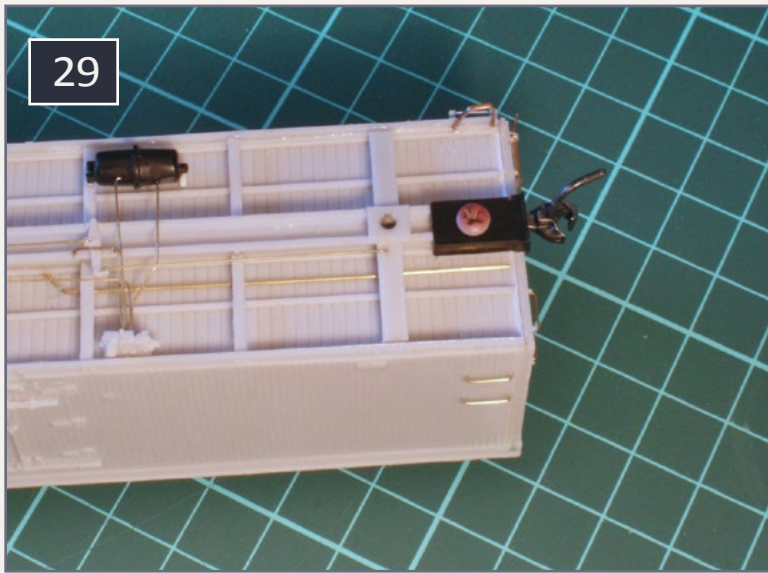

**29. One corner step installed.**



**30. Formula 560 Canopy Glue.**

Apply a small amount of canopy glue to each mounting point, and attach the running board. Weights help it cure flat and straight.

Now, add the running board end supports. These are supplied as resin parts in the kit but removing them is time-consuming and a bit of a chore, so I substitute styrene. They need to be .010” X .020” to make them look reasonable. Add two of these to each end with CA. I went a bit overboard and put some small links of chain at the bottom of the hand-brake link to add some extra detail.



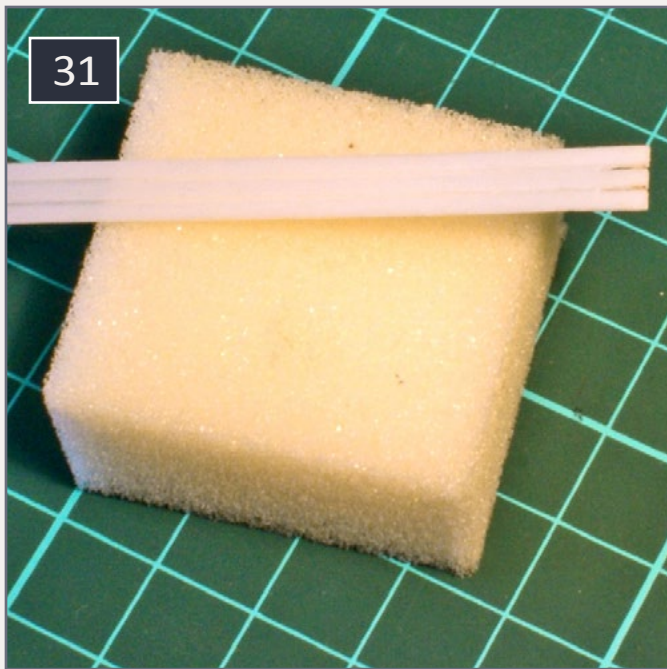

**31. Ends of the running board have been notched for added detail.**



**32. The end brace is attached to the underside of the running board.**

Now the kit is complete and all I have to do now is paint. That will be for a future article. For now I have the completed kit to admire. 

**Pictures continue on the next pages ...**



contents



index

33

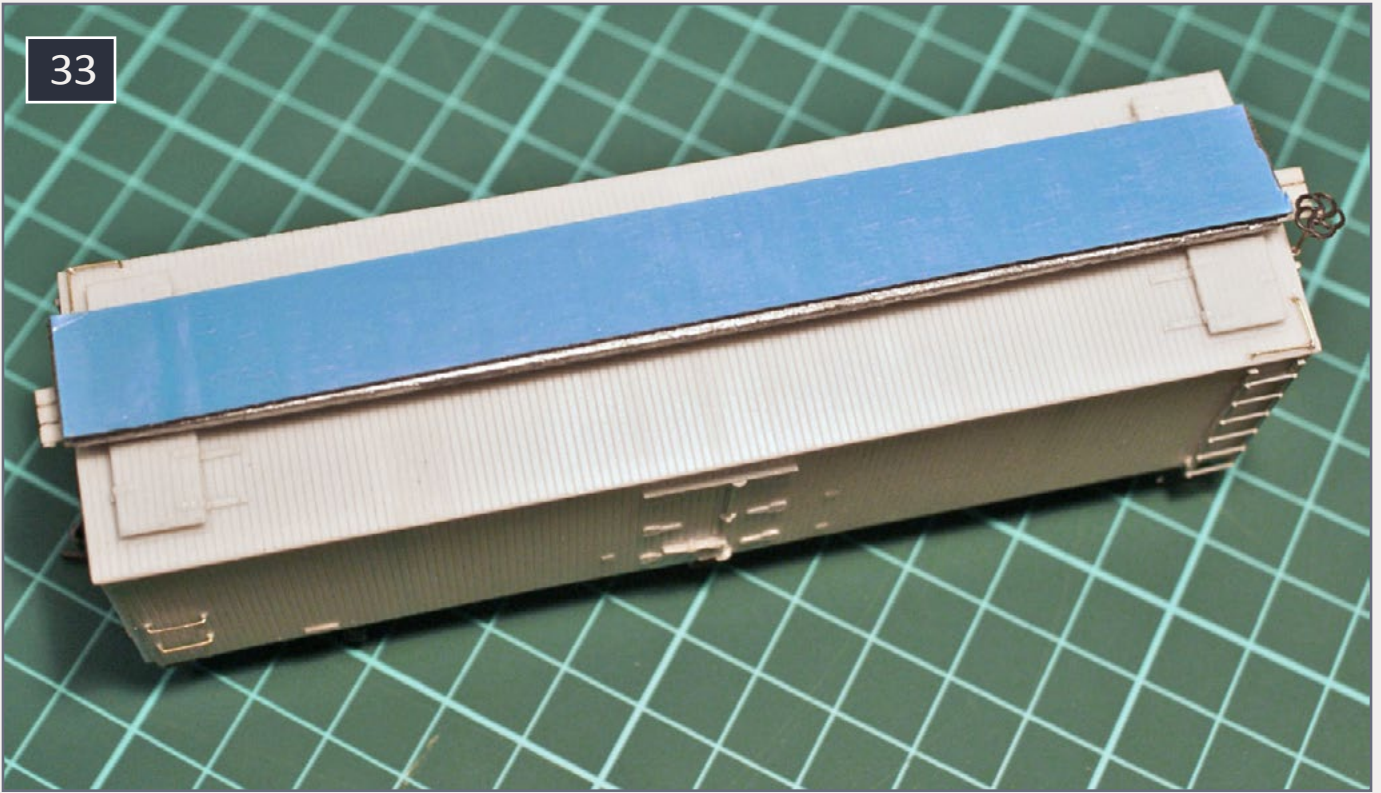

**33. Installing the running board. I weight it so that it is straight and level.**

34

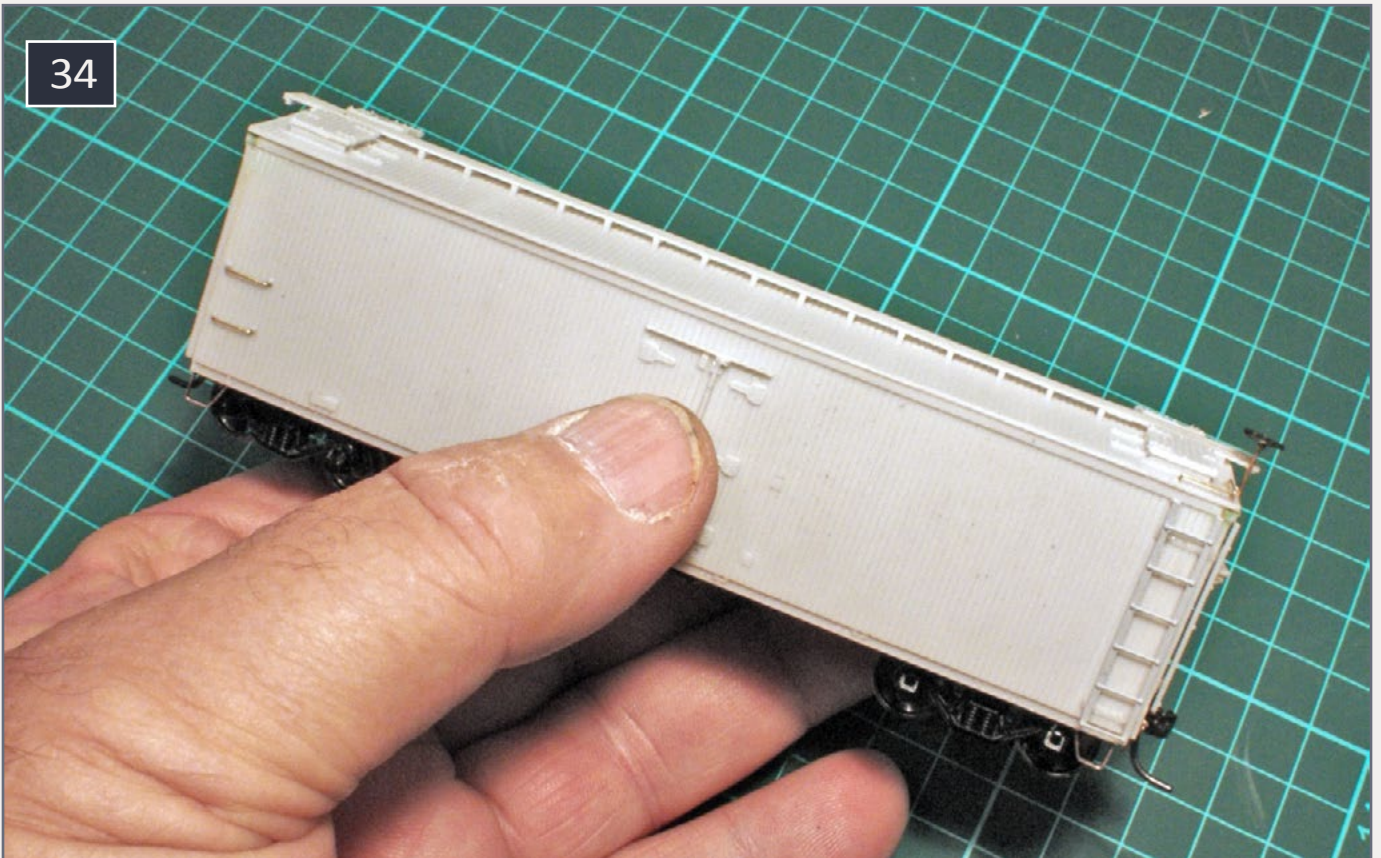

**34. Once it cures you should end up with something like this.**

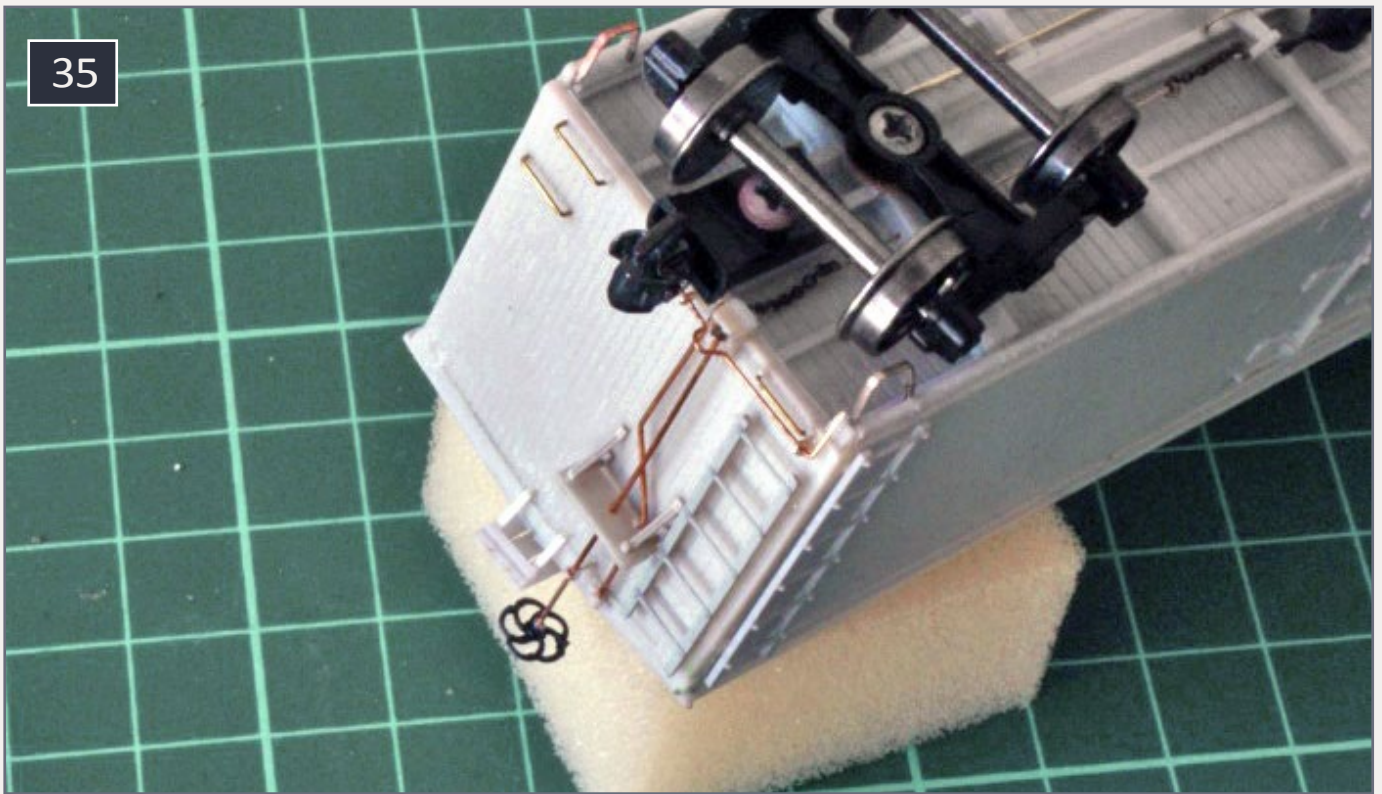

35. End supports in place on both the A and B ends of the car.

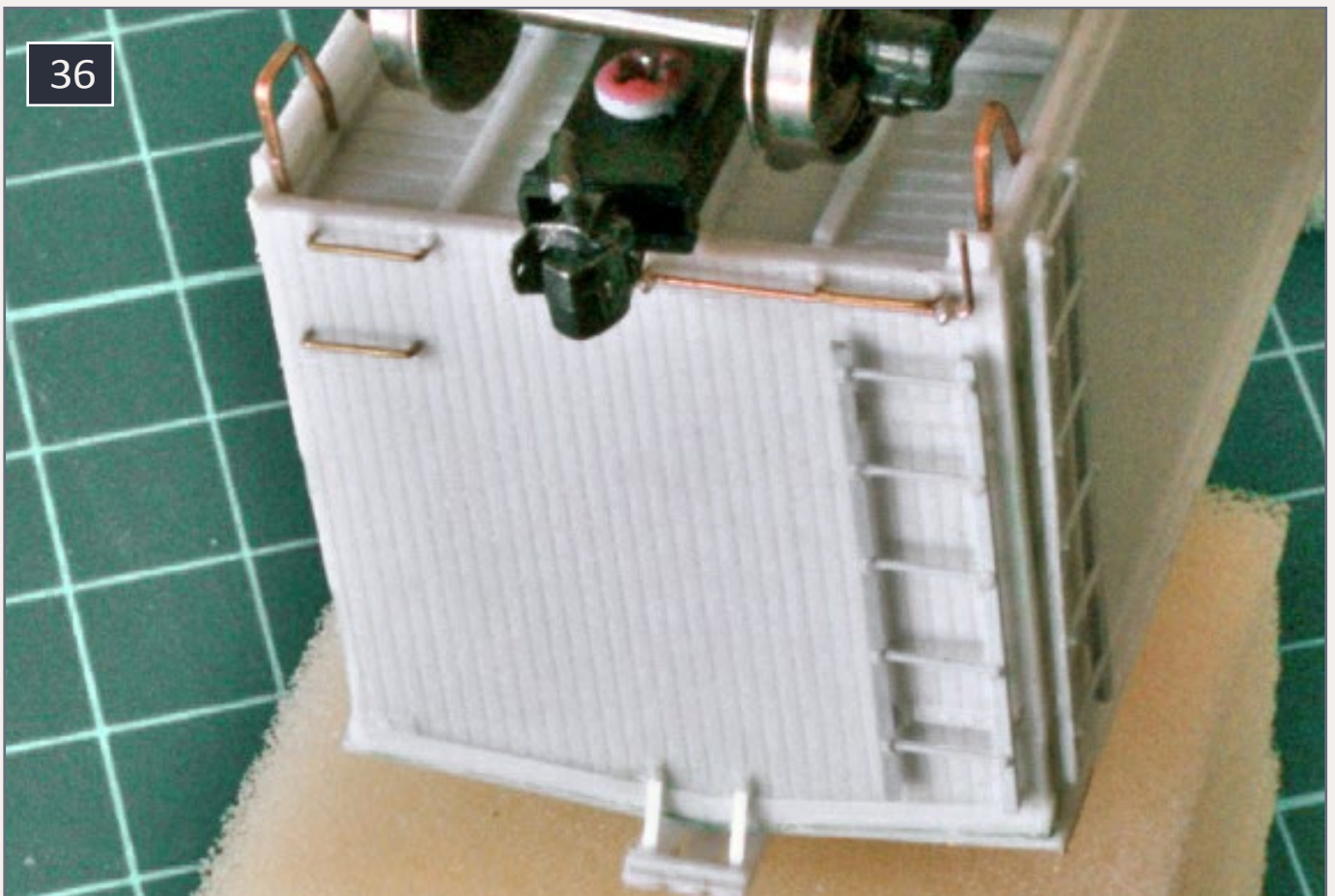

36. The completed car ready for painting.



contents



index



37. Completed resin car.



**Reader  
Feedback**  
(click here)



*Advertisement*

# Rslaserkits

Stop by and check us out at the  
Narrow Gauge Convention  
in Kansas City Sept 3rd-6th

**Dealers welcome**  
**Salem, OR**  
**503-371-4290**



**Custom Laser Cutting  
and design**

Sales@rslaserkits.com





Rob McLearn is a retired police officer and Vietnam veteran living in Kingaroy, Queensland, Australia.

He has been in model railroading since 1976 starting with a small Hornby train set given to him by his wife. She also gave him a copy of HO Primer, that encouraged him to model

the North American scene. The Warbonnets, Catswhiskers FT's and the heavy steam engines by Baldwin attracted him to the Santa Fe.

Rob has built two previous layouts in HO and started one in N before moving to his current address and switching back to HO for the current project.

Rob models the Santa Fe's First District of the Los Angeles Division, the line from San Bernardino over Cajon Pass in 1947 which was suggested to him by a friend, John Armstrong in the Union Pacific Model Railroad Club in Queensland. This allows him to model both the Santa Fe and the Union Pacific. Currently he is finishing a 40 by 25 foot outbuilding to house the next layout.

Rob credits Otto Kroutil, Andy Sperandeo, Ted York for his inspiration in the Santa Fe, and particularly Richard Hendrickson for his interest in freight cars and resin kits. He also runs a small custom painting business and enjoys camping and heading into the bush in a 4WD with his family.

Rob has been married to his wife Jan for 42 years and has two daughters and three grandchildren.

# REALISTIC SWITCH CONTROL

## MAKING YOUR SWITCHMAN WORK

– by Trevor Marshall

Photos by the author



**I** like to devise ways to emulate the actions of real railroaders on my layout. I think it helps immerse operators into the story I'm trying to present in miniature.

I've done this in several ways on my layout, which recreates the Canadian National Railway's branch line to Port Rowan, Ontario in the 1950s.

One idea I implemented on the layout that visiting operators really seem to enjoy is my method of controlling the

**A brakeman watches as CNR 80 – a venerable 2-6-0 – pulls forward off the turntable lead in Port Rowan, Ontario. The author's layout is accurate but simple. He uses G scale switch stands mounted on the fascia to throw and lock the turnouts.**



contents



index

track switches. And while my layout is S scale, this system will bend the iron in any scale.

The story starts in the back yard...

## A miniature switch stand

While browsing the Web, I found some wonderful G scale switch stands. These stands, sold by Sunset Valley Railroad [sunsetvalleyrailroad.com](http://sunsetvalleyrailroad.com) are built from brass castings and machined parts. They're fully assembled, stand about 3½" tall, and operate like a real switch stand. To throw the switch,



one lifts the lever, rotates the stand 90 degrees, and drops the lever. Notches at each end of the lever's travel lock the switch points in position.

The switch stands – Sunset Valley part “SW ST” – are designed to mount directly on the head blocks (the two long ties) of a G scale

**2. Brass switch stands like this are mounted on shelves and operate the switches on the author's layout.**





**3. Switches on the author's layout are operated using these brass switch stands mounted on shelves. Engraved labels indicate which track switch each stand controls.**

turnout and are robust enough to take a direct hit from falling acorns or high-speed critters.

I wondered if I could use these as switch controls for a traditional indoor model railway. I talked to my friend Chris Abbott, and we decided a switch stand could be mounted on a small shelf on a layout's fascia. But we weren't sure how to translate the stand's motion to a turnout mounted on the layout.

## **BullFrogs to the rescue**

Then Fast Tracks provided the answer, with the BullFrog [handlaidtrack.com](http://handlaidtrack.com) manual switch machine. This nifty device is easy to build, install, and is operated by plastic control rods



(actually, a rod and a sleeve) used in the radio-controlled aircraft hobby. They would work beautifully with the Sunset Valley switch stands.

The switch stands provide positive locking at both extremes of the throw, and I control frog polarity on my layout using Frog Juicers from Tam Valley Depot [tamvalleydepot.com](http://tamvalleydepot.com). I built the BullFrogs without the microswitch or ball and spring that provide those functions in the switch machine itself. I gave those parts back to Fast Tracks owner Tim Warris the next time I saw him.



**4. A switch stand lined and locked for the normal (straight) position. The target is parallel to the fascia.**



**5. The same switch stand unlocked and lined for the diverging route. The target is now perpendicular to the fascia.**

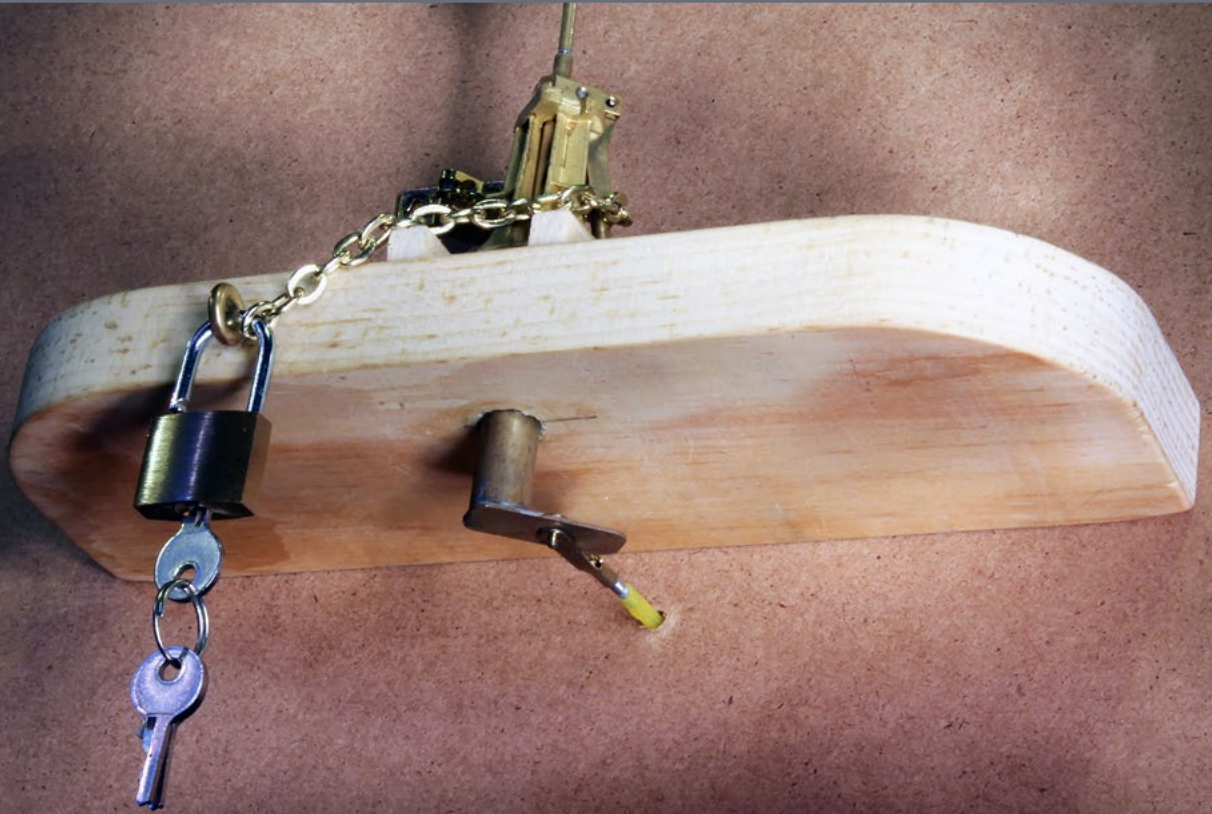

## 6. The modified mechanism of the switch stand projects below the shelf to connect to plastic control rods. The lock is an inexpensive luggage lock.

My initial thought was to connect the control cable directly to the bottom of the stand, using a piece of steel wire between two head blocks to represent the head bar (throw bar) on a switch. This wire could run through a hole in the fascia to connect to the control rod. But we realized this would present some challenges.

The biggest challenge was that such an arrangement would only give us about  $\frac{1}{4}$ " of throw, which wouldn't be enough for the BullFrog; we wanted the BullFrog's throw to be long enough to provide positive pressure on the points of a switch, to hold them securely against the stock rails.

### **Modifying the switch stand**

Chris solved the problem by fabricating an extension for the bottom of the switch stand with brass shapes from K&S Metals [ksmetals.com](http://ksmetals.com). Here's how to modify the stands:



Cut the extension from 3/8" diameter brass tube. Length will vary depending on the shelf used, but it needs to be long enough to connect to the bottom of the stand and extend about an inch below the shelf.

Cut a collar for this extension from 7/16" brass tube. The length will be the same as the depth of the shelf. Clean up the cut ends to make sure the 3/8" brass tube slides smoothly through this collar.

Solder a 1" length of brass bar stock (see Bill of Materials) to the bottom of the extension tube creating a lever. Drill a couple

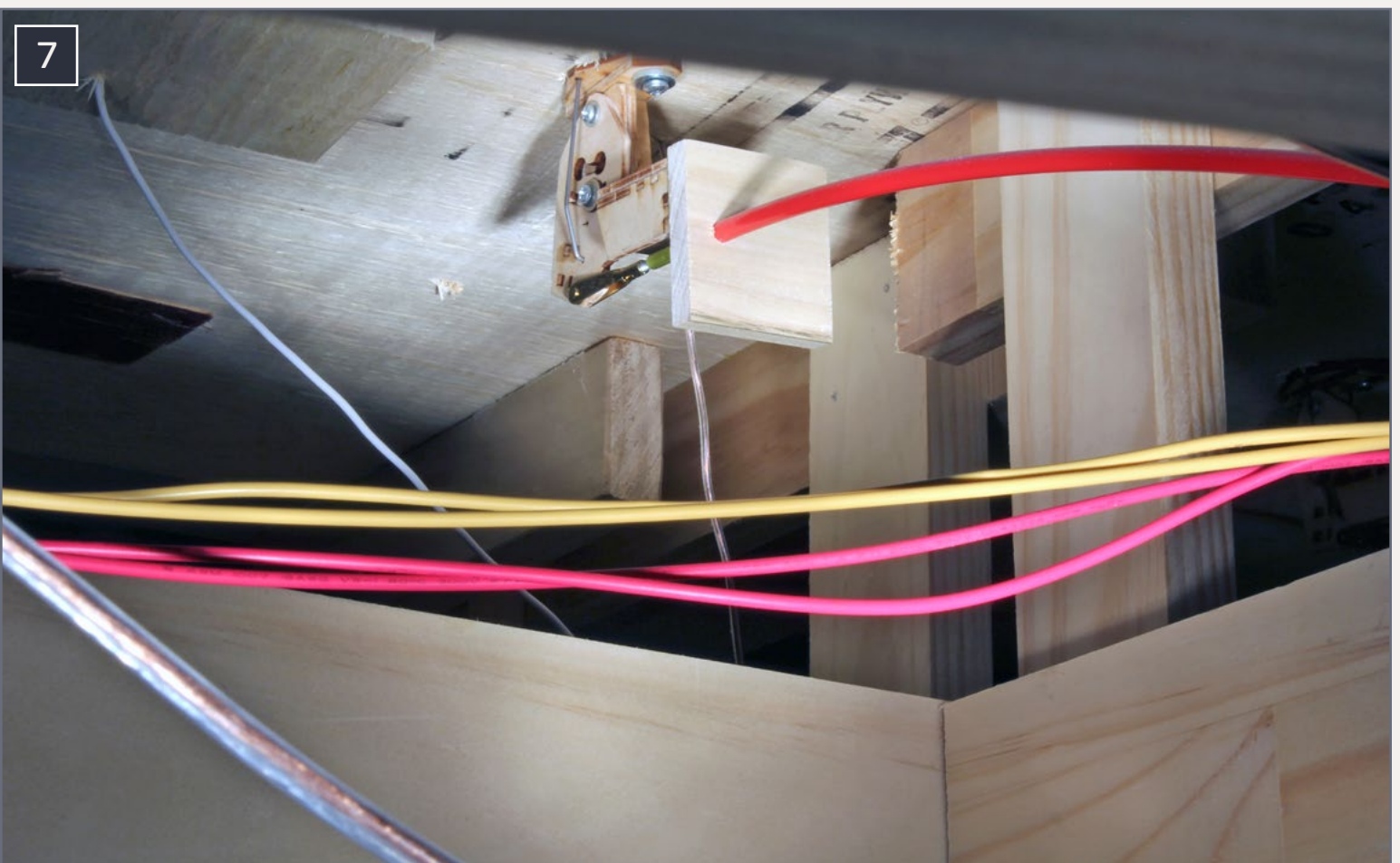

**7. At the other end of the plastic control rod, a BullFrog manual switch machine moves the points. The BullFrog has been fitted with a larger wooden face to support the control rod, since the use of clevises required moving the position of the rod.**

of holes in the lever to provide some choices for connecting the control rod.

The final step is to cross-drill the extension tube to secure it to the bottom of the stand with a machine screw, so the extension will rotate when the stand is operated. The machine screw replaces the threaded rod that comes with the switch stand, so use the threaded rod to determine what size screw to use.

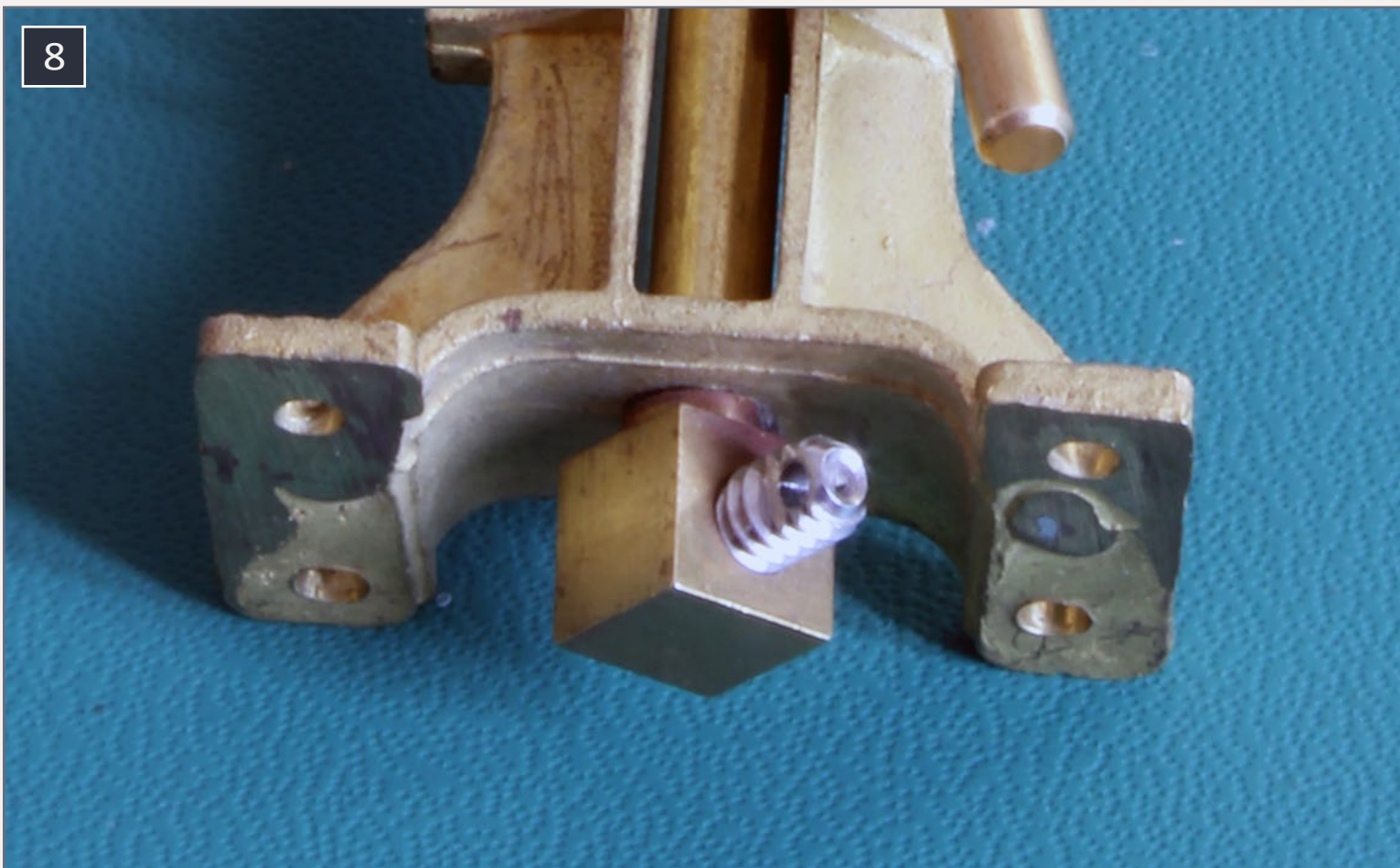

**8. Here's a closeup of the stock switch stand from Sunset Valley Railroad. As designed, the brass cube at the bottom of the stand is drilled to accept a threaded rod. This will be replaced with a screw to secure a brass tube to the cube and create the extension lever required for use on the layout.**



contents



index

The location for cross-drilling is important. When the stand is mounted on its shelf, and thrown half-way, the lever should be parallel to the fascia. The best way to determine this is to insert the extension into the shelf, mount the switch stand, and determine where the hole needs to be. It may vary between switch stands.

## **Mounting the switch stand**

For each stand, cut a shelf 8"x 2-3/4" from 3/4" pine board. The shelf is deep enough to make using the switch stands comfortable. Sand the shelf to remove sharp edges and round the aisle-side corners so they won't catch on clothing. Drill a hole to a press-fit for the brass collar, then space the two head blocks to accommodate the mounting holes on the base of the switch stand and glue them in place.

# **...make sure that there's some framing support for each shelf.**

Insert the brass extension tube from the bottom of the shelf and bolt it to the bottom of the switch stand. Then mount the switch stand to the head blocks with small screws.

To mount the completed assembly to the layout, I determine where each control would go, making sure that there's some framing behind my layout's Masonite fascia to support each shelf. For each switch control, I locate and drill two holes in the fascia for mounting screws, then use these holes to locate and drill holes in the back of the shelf. 2 1/2" screws will provide plenty of support.



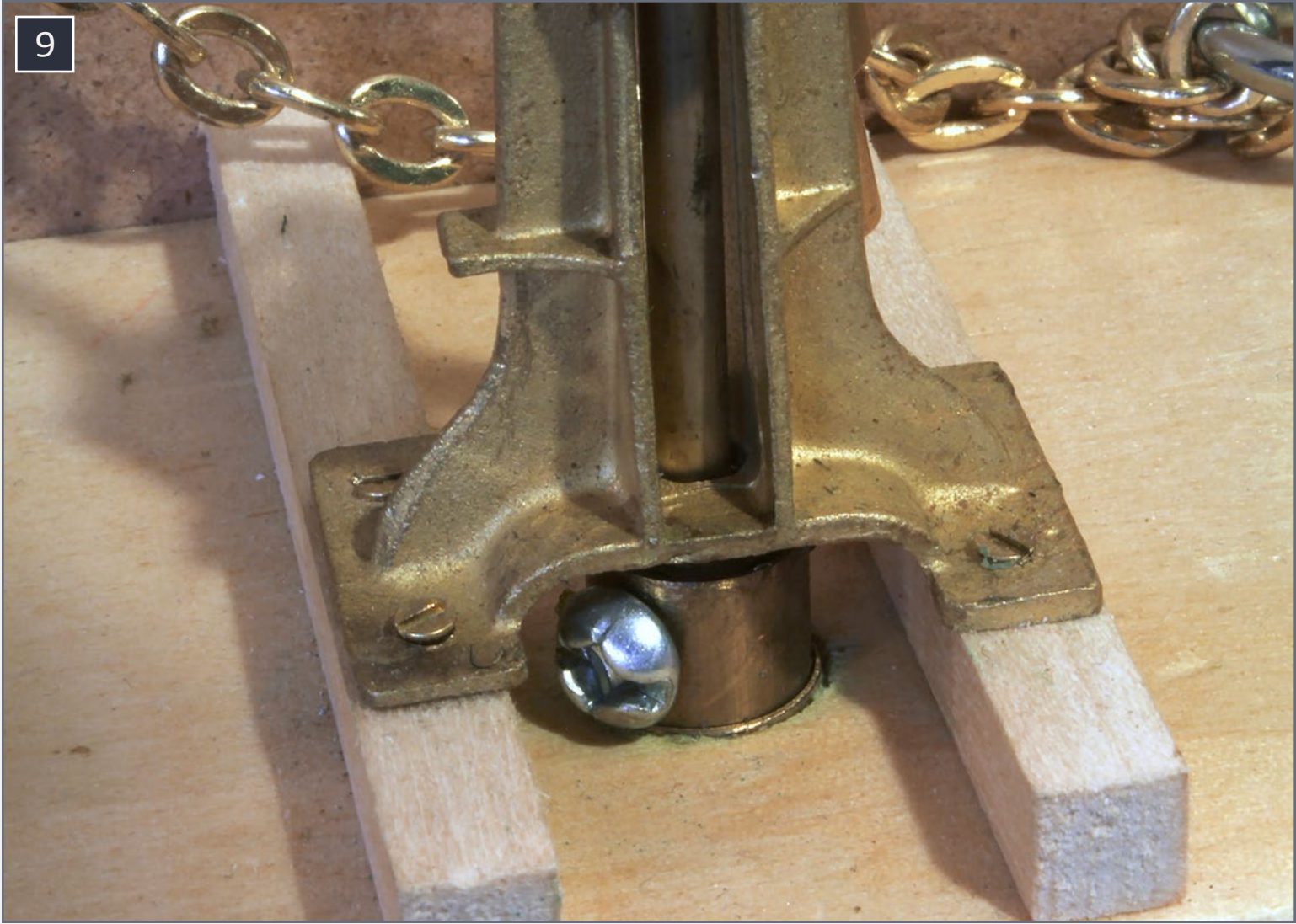

**9. Here's a closeup of the base of a modified switch stand. It shows the two sizes of tubing used to make the extension that transfers the movement to a lever below the shelf. It also shows the screw that replaces the threaded rod to secure the extension to the stock switch stand.**

Before securing the shelves in place, I note the location where the control rod will pierce the fascia, then drill a hole in the fascia, sized to create a press-fit for the rod's outer sleeve. I finish the installation by connecting the control rod between the switch stand lever and the appropriate BullFrog. To make this connection, I use appropriately sized Gold-N-Clevises from Sullivan Products [sullivanproducts.com](http://sullivanproducts.com), a supplier to the RC aircraft hobby. I liked the clevises so much I used them at the BullFrog end of the linkage, too.



I was fortunate to secure a supply of white-metal kits for CNR switch stands with rotating targets and handles, once offered in several scales by Alder Models, a Canadian company that sadly no longer exists. For each switch on the layout, I mounted an Alder Models stand on the head blocks and added a home-made linkage to the head bar so that the target and handle rotate as the points are thrown.

## Locking the stands

As a final step, I wanted to be able to lock the switches in their “normal” position – with the points aligned for the main track. (As James McNab pointed out in his article in the December, 2013 issue of *Model Railroad Hobbyist*, “Railroads lock everything.” [mrhmag.com/2013-12-dec](http://mrhmag.com/2013-12-dec)).

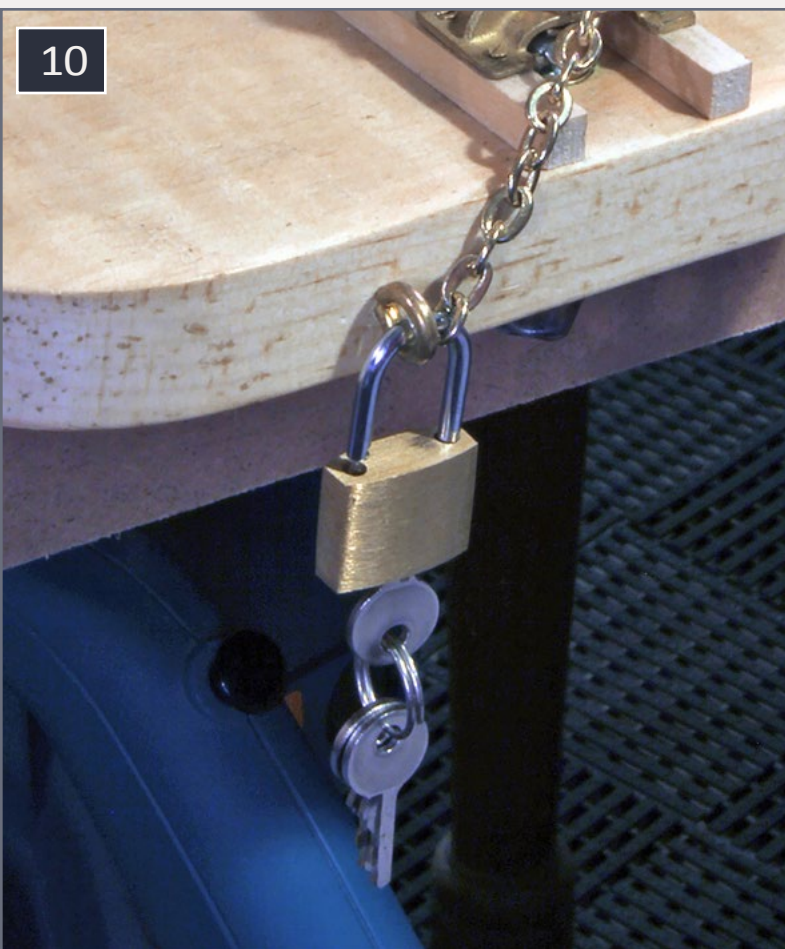

10

**10. The inexpensive luggage locks used to lock up the railroad.**

The answer was surprisingly simple. I found some cheap (\$1.00 each) brass luggage locks at a local hardware store, all keyed the same. While this would not provide me with a great measure of security on my luggage, it made them perfect for my layout. I also picked up some hardware used for adding keeper chains to jewelry box lids, and some brass eye-bolts. I mounted the keeper chains on the fascia, then determined where to place the eyebolt on the front of





**11. To help operators confirm that the turnouts have been thrown, S scale switch stands with swivelling targets are mounted to the head ties of each switch.**

the shelf, such that the lock would slip through and hold the chain across the lever on the switch stand.

## **Doing real work**

My working switch stands have been a hit with operators. They do a great job of emulating the work involved in operating a switch. Consequently, they also encourage operators to take their time and think about what they are doing. Unlike push-buttons or toggles, these make it impossible to quickly line a route through town with a few finger flicks. Throwing a switch takes time, so conductors quickly figure out how to do their



switching in a way that minimizes the number of times they have to bend the iron.

If there is any drawback to this system, it's that it is expensive. The switch stands cost slightly more than a top-quality switch machine. But I feel they're worth the cost – especially when one contemplates the amount of work involved in building them.

In addition, my Port Rowan branch has only eight turnouts, so I felt I could afford to invest a little more in the control system – and I'm really glad I did. I'd definitely use this system again – even on a more complex layout – because it adds a lot to the operating experience. ✓



**Playback problems? [Click to try a different version.](#)**



Trevor Marshall is a lifelong model railway enthusiast who has worked in several scales and gauges – including HO, On2, Proto:48, and various garden scales. He started his current S scale layout in mid-2011 and writes about it at: [the-modelrailwayshow.com/cn1950s](http://the-modelrailwayshow.com/cn1950s)

Trevor created and co-hosted “The Model Railway Show,” a podcast about the hobby, and has written several dozen articles and reviews for the hobby press.

Trevor lives in Toronto, Canada – where he divides his time between his model railway, his work (a mix of speech writing and technology reporting) and training his Border Collies to work sheep.

*Advertisement*

## Touch Toggles™ help *your* Creation

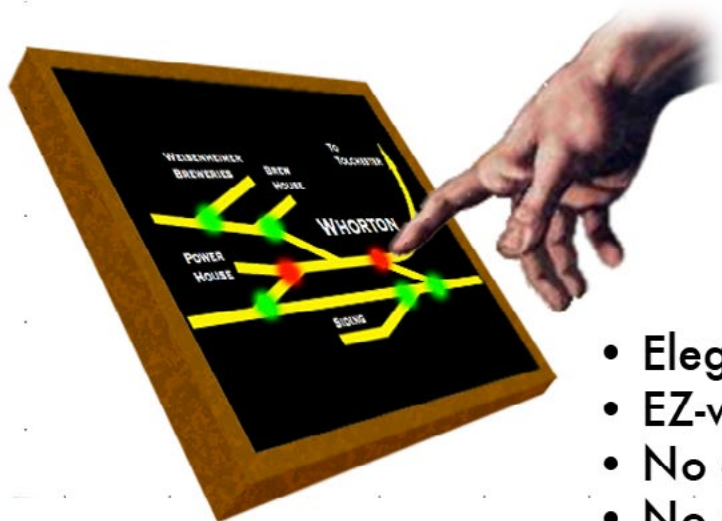

See our website for a video introduction!

- Elegant controls
- EZ-wire or plug-in systems
- No drilling
- No soldering



**BERRETT  
HILL  
TRAINS**

Made in the USA



*What will they think of next?*

[www.berrethillshop.com](http://www.berrethillshop.com)



Email



Phone



contents



index

**Garden-scale switch stand: Part "SW-ST"**

**Sunset Valley Railroad**

[sunsetvalleyrailroad.com](http://sunsetvalleyrailroad.com)

**BullFrog manual turnout control: Part "BF-0002" Fast Tracks**

[handlaidtrack.com](http://handlaidtrack.com)

**Gold-N-Rod R/C cable: Part "S503" (pkg of 2)**

**Gold-N-Clevises: Part "S527" (pkg of 12)**

**Sullivan Products [sullivanproducts.com](http://sullivanproducts.com)**

**Extensions for the switch stands:**

**3/8" brass tubing: Part "8135"**

**7/16" brass tubing: Part "8137"**

**.032 x 1/2" brass strip: Part "8241"**

**K&S Metals [ksmetals.com](http://ksmetals.com)**

**We're not mind readers.**

**If you want more articles of the kind you like, click the feedback button and rate articles!**

**Feedback button  
looks like this:**



**Make sure you click this  
button and rate articles!**

# August ...

ON TRAINMASTERS TV



**B-2-T-B Episode 2: Track Planning for a new layout**

# Back to the basement

**HOT! August super-saver special underway!**

**Visit TrainMasters.TV website**

## EVENTS



Lionel Strang at Cleveland Train Show

## LAYOUTS



Cleveland Train Show Layouts

## PROTOTYPE



Streamliners at Spencer - Finale

## HOW-TO



BONUS: Backshop Clinic modeling tips



# The Kayton Short Line

**\$500 contest  
2nd place**

**– by Robert Douglas  
Photos by the author**

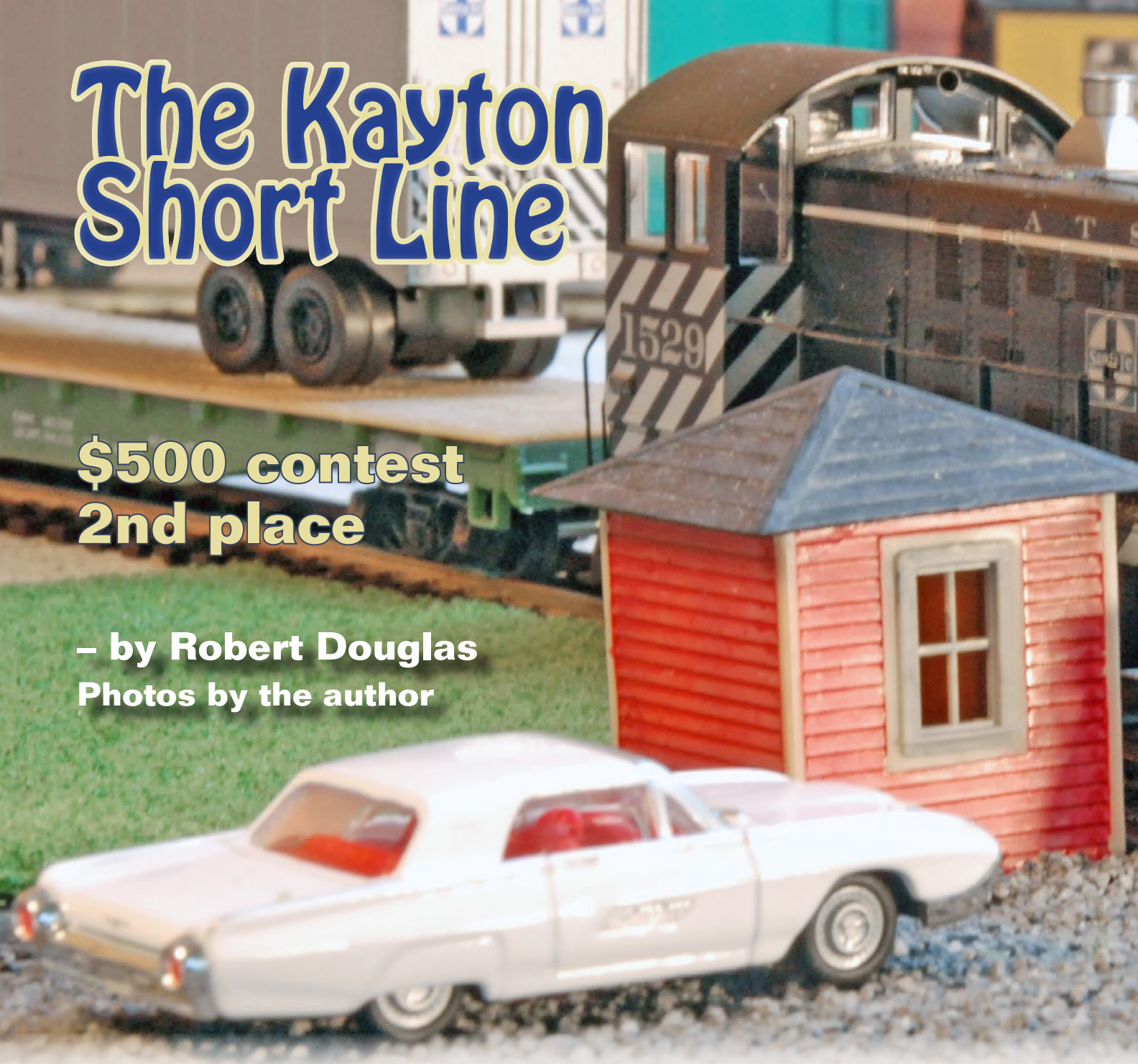

**R**ailroads are built for a reason and so should be model railroads. My reason for building the Kayton Short Line was to keep me sane by giving me somewhere to relax and run trains without expending vast amounts of energy and money. It is also to create a “chainsaw” layout on which to

hone my hobby skills. To do this I used what I had laying around; there are no grades, fancy woodwork or scenery.





**Morning sunshine illuminates the nose of the Alco S4 which is holding down the switching duties today.**

There are almost no structures at this time but I have an operating layout that gives me hours of satisfaction and enjoyment shuffling freight cars.

The Kayton Short Line is small switching layout with no specific prototype. The premise of the layout is either a small town branch line or a city industrial spur to which a daily freight



contents



index

trundles in and services the industries. I love the '60s and '70s era of first- and second-generation diesels, so I aimed for the late '60s and use 40 and 50 foot cars plus some 36 foot covered hoppers. I switch with either a GE 44-ton loco or an Alco S4, both of which are nicely sized for the layout.

My main constraint is space. I had a 4x8-foot area already from an earlier project that fell through, so I reused it. The key elements I wanted were:

- Lots of car spots
- A two- or three-car runaround track
- Easy reach to all car spots for coupling and uncoupling
- An inbound / outbound track to serve as a staging track
- Did I mention lots of car spots?

As with all model railways, the first issue is coming to grips with compromise. I wanted 22 inch and 24 inch radius curves

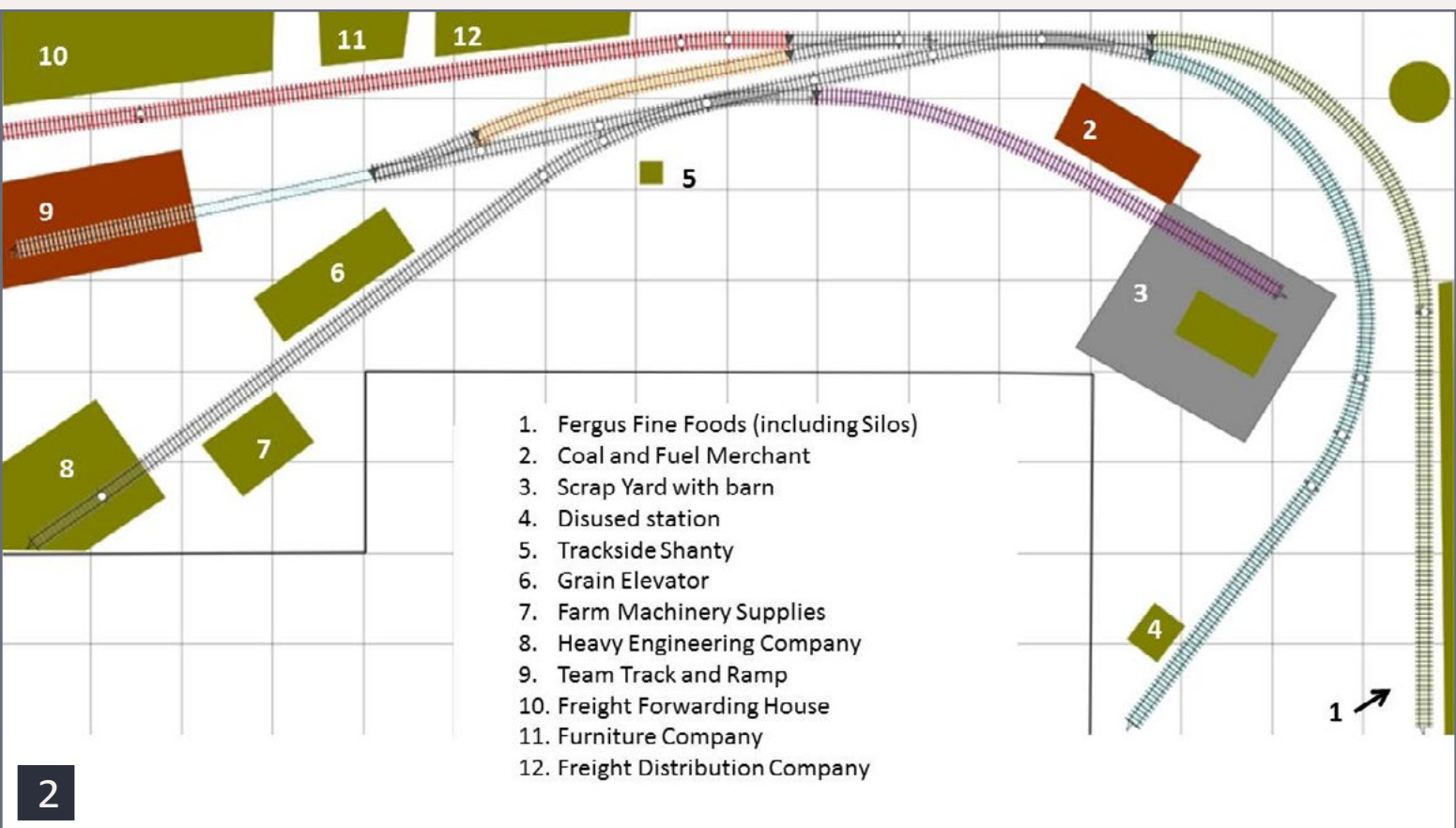

## 2. Track plan for the Kayton Short Line.



with long spurs. I very quickly realized that 18 inch radius curves may not look as good but they let me get more track into a tight space. Of course, the key element is having lots of car spots even if coupling and uncoupling on an 18 inch radius curve is not the easiest thing to do.

The track plan evolved as I tested various combinations of switches and lengths of flex to get enough operating room. The plan drawn has one significant difference to the railroad actually built, in that the runaround is better fitted and longer on the plan than on the layout.

## The track plan evolved as I tested various combinations ...

The “U” shape of the layout means it can easily butt against a wall as, unlike an oval 4x8 layout access from both sides is not required. It also ensures that all switches and car spots are in easy reach for the operator.

The final layout [2] as described has 16 car spots, space for six cars and a loco on the staging track and some spare room for handling cars during switching. However, if you run it with 22 cars it would probably get a little busy. I started operating with only eight freight cars and have slowly increased that number so that now I run with 19 freight cars and loco. This leaves enough room to shuffle cars but causes some enjoyable operating “headaches.”

### Track descriptions

**Track 1** serves Fergus Fine Foods, a large commercial food operation receiving fruit, flour and food oils whilst constantly



contents



index

shipping loaded 40' and 50' insulated box cars of product. As such it has three car spots at its three doors for the box cars and reefers, and a silo spot for the tank cars and covered hoppers. It is treated as the "important" customer.

The next track is the inbound/outbound staging track that links with the mythical town of Santel.

**Track 2** has two car spots, for the local scrap metal merchant and coal dealer. It has a bit of spare space and comes in handy for holding cars during switching moves.

**Track 3** is a good long straight line, with two car spots for local manufacturers located at the far end, and another three car spots for a grain elevator, making a total of five. Because grain traffic is seasonal, sometimes there is a bit of empty space to spot cars here too.

**Track 4** is the local team track and doubles as the lead for the runaround. It is deliberately sized to accommodate only a loco and two 50 foot cars, which means a bit of an enjoyable problem if there is a car spotted there.

**Track 5** has five car spots, spaced a little bit apart so that cars need to be uncoupled to be spotted to their locations. Here I have a freight forwarding agency, a furniture company and second small general freight company. Again, there is a little excess capacity to spot cars during moves.

## **Locos and rolling stock**

Our local version of eBay, called TradeMe, had a DC Bachmann Alco S2. These are nice little items with their can motors and, given a good DC power pack, should work well. However, like most other people with the \$500 layout, I would urge you to splash out a little more and buy a bottom end DCC system and



DCC loco. I use a Digitrax Zephyr and Bachmann Alco S4 with DCC and sound and she purrs along nicely. I bought the S4 from TradeMe for a mere \$70 New Zealand. But I won't include that here as it was very much the exception and they normally go for more than double that.

I have bought all my rolling stock off TradeMe and set a limit of \$10 to \$12 per car. I don't buy them unless they have Kadee couplers fitted and preferably with metal wheels. For eight cars and a loco the total cost would be \$171 at the most. With eight cars it would take 15 to 20 minutes to switch the layout but now I can be enjoyably lost for over an hour shuffling cars around with 19 cars. A loco and 19 cars would be \$303.

I have specified a new MRC DC throttle and power pack. Like track work, the quality of the throttle has a great impact on the enjoyment of the layout and I have used an MRC DC dual throttle in the past and was very pleased with it. The unit specified is not the cheapest so you could shave a few dollars there as well.

## Table One – Rolling stock and power pack

Item	No	Source	Cost
<i>Bachman Alco S2 Switcher</i>	1	TradeMe	\$75.00 (NZD)
<i>Assorted Freight Cars (max \$12 ea)</i>	8	TradeMe	\$96.00 (NZD)
<i>DC Power pack and throttle MRC AA370 Railpower</i>	1	Trainworld.com	\$47.99 (NZD)
		<b>Total</b>	<b>\$218.99 (NZD)</b>



contents



index

## Benchwork and roadbed

What you spend really depends on where you want to locate the layout. My layout was built on pre-existing benchwork for an 4x8 N scale layout that never happened. If I were starting from scratch I would bolt brackets directly to the walls and thus I have allowed for six good heavy-duty brackets. Some additional framing timber may help to secure the plywood base. For the track base I have used one inch (25mm) expanded polystyrene foam. Thicker boards would give more depth for scenery but would also be more expensive. On the whole I feel that one inch is fine for scenery on a switching layout.

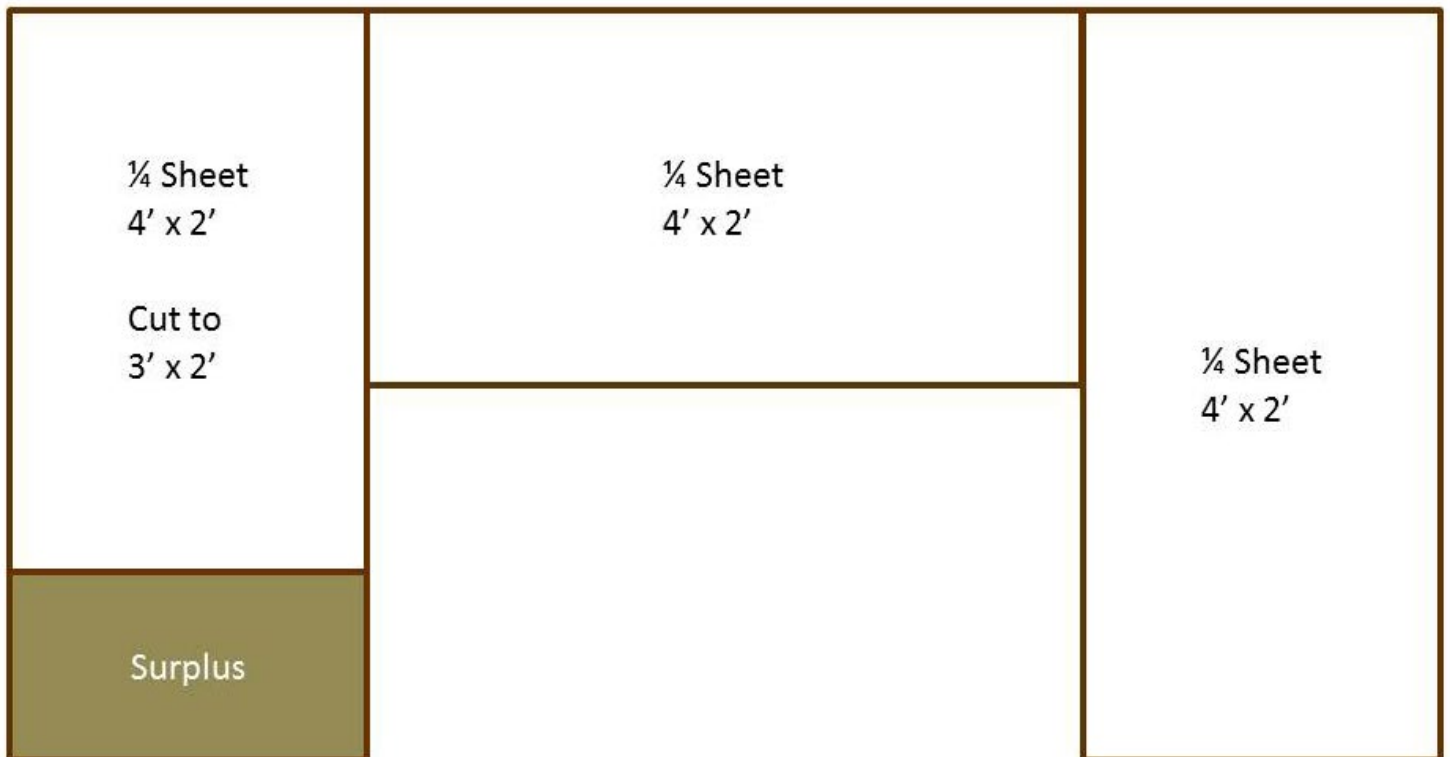

3

### 3. Cutting guide and sheet use.

## Table Two – Benchmark

Item	No	Source	Cost
Full sheet, 12mm Plywood (1/2 inch) (cut into four ¼ sheets – you'll have one spare)	1	Mitre 10 Hardware	\$39.89 (NZD)
25mm (1 inch) polystyrene sheet (Cut into four ¼ sheets)	1	Bunnings Warehouse	\$20.48 (NZD)
Wall Brackets - \$9.82 ea	6	Mitre 10	\$58.92 (NZD)
		Total	<b>\$119.29 (NZD)</b>

## Track

I use Peco switches because they are easily available locally and their spring system means ground throws or other mechanisms are not required. I have purchased a lot of these used from online auctions, but it does mean waiting until they come up at the price point around \$10 each that I am comfy with. Brand new these are around \$20 to \$25 NZD each, depending on discounts. Given the crucial nature of good switches to smooth operation I would build any new layout using only brand new switches and have priced them in here from a US source.

All other track is flex track totalling a little over 26 feet. If you wanted you could substitute set track which would make some of the construction easier for novices. I used nine lengths of flex which allows a mere 12 inches to spare. One extra length may help but I'm keeping costs down. To be honest, it is probably easier to buy this new rather than buy peoples' cast-offs from online auctions. I have priced new track from a U.S.



contents



index

source, however, for me in New Zealand, the cost of shipping from the U.S. would be huge!

## Table Three – Track

Item	No	Source	Cost
Peco SL92 LH #4 Switch Code 100 (\$20.39 ea)	4	Trainworld.com	\$81.56 (NZD)
Peco SL91 RH #4 Switch Code 100 (\$20.39 ea)	2	Trainworld.com	\$40.78 (NZD)
Peco Wooden Tie Flex Track Code 100 (\$5.99 ea)	9	Trainworld.com	\$53.91 (NZD)
		<b>Total</b>	<b>\$176.25 (NZD)</b>

*Note: Sourced locally the switches would be approx. \$21.00 each and the Flex track \$8.00 each*

## Scenery and structures

Here I must come back to the original reason for building the railroad. It was built to keep me sane by providing enjoyable train operations. Yes, scenery and structures add considerably to this enjoyment. However, as a starting point, I'm loving just shuffling cars around. Thus my structures are food skewers and printed flags, and my scenery is nil. I may splash a little paint around later. This sounds like cheating but I derive hours of pleasure from shuffling cars without siphoning funds off for structure kits. Having said that, I constantly watch online auctions for interesting structures and have a couple of Walthers Cornerstone kits and a Campbell Scale Models grain elevator under construction. All came from auction sites.

## Table Four – Scenery and structures and extras

Item	No	Source	Cost
Food skewers			
Paint			
Solder, light gauge wire, pins, nails, screws etc.			
Additional 1 x 2 bracing if required			
One or two structure kits to start off			
Additional freight cars, Kadee #5s, height gauge, washers etc.			
		<b>Total</b>	<b>\$ Whatever is left</b>

### Total cost

I have priced everything in New Zealand Dollars and the total is shown in Table Five

### Table Five – Total cost

Item	No	Source	Cost
Rolling stock and power pack			\$218.99
Bench work			\$119.29
Track			\$176.25
Additional items			
		<b>Total</b>	<b>\$514.53</b>

At first glance it would appear that I have missed the mark however, the New Zealand dollar exchanges at only \$0.82 USD! So, at the current rate, \$514.53NZD is equivalent to \$421.92USD, leaving \$78.00USD for additional bracing timber, freight cars and some structure kits!



contents



index

# Putting it all together – Operating the Kayton Short Line

The key to this layout is how it operates. Each car spot is labelled with an industry and car spot number and one track is set aside as an inbound / outbound (staging) track. My pet peeve is having to “hand of God” trains on and off the layout. This track is large enough to store a loco and up to seven or eight cars ready to come into the switching area

Looking at [4] you will see I have allocated car spots starting at the spurs’ far end from the switch and then consecutively numbering forward until I reached the switch or the vacant space. Don’t forget to allow for the length of the loco when

4

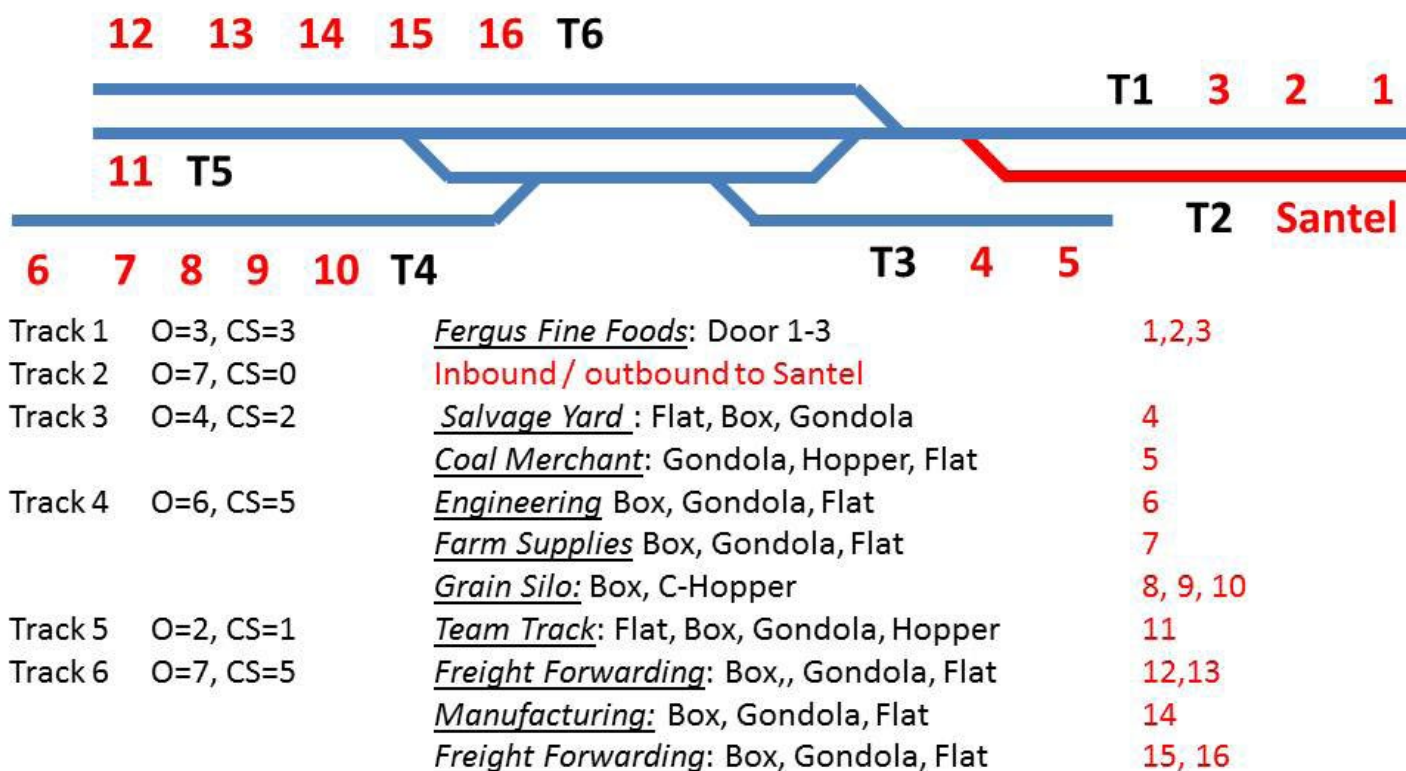

## 4. Car spots and occupancy.





## 5

1	8/9/10	15	XE
2	8/9/10	16	X1
3	8/9/10	X	3A
4	11	X	
5	12	X	
6	13	X	
7	14	X	

Car Spot Markers  
20mm x 10mm  
(0.8" x 0.4")

Print in color  
or on color cardstock

## 5. Car spot markers.

you measure the occupancy, especially for the inbound/outbound track and the runaround lead track. I use only 40 foot and 50 foot cars, and so have spaced the car spots accordingly. Some groups of car spots assume cars coupled together whilst other car spots leave a gap between cars which makes placing freight cars “on spot” just that bit more difficult. On the whole, I have left the first part of each spur free.

The next step is to mark the car spots on the layout. Initially, I simply wrote numbers on the roadbed but soon found I couldn't see these through the cars. I drilled a small hole in the soft board and inserted a cooking skewer to indicate the location of the car spot. The skewer denotes where the freight car's door should be. Adding flags gives a little more meaning to the car spots but if you already have some buildings to install it will certainly enhance the space and look much better!

The final step is to make up a set of car spot markers, one for each car spot plus several “X” for exchange (these cars are switched to Track 2 in any order). I printed one of each number 1 to 16 and six “X” marks on some lightweight card and cut them out. Now you're ready to go!



contents



index

# Running a session

6



On my “one track in full view” staging yard, I normally have cars attached to the loco while other freight cars are scattered about the layout on various car spots after the last session. First I mix all of the Car Spot Markers in a container and then place them on the cars. You can be as random or directed as you feel. In my case, I never put an “X” on car already sitting on the inbound and I usually don’t put the same marker back on a car.

## 6. An inbound freight ready to go.

Because I have some specific industries in mind, I generally choose the type of car that should have a specific spot. For instance, I use mainly grain hoppers or box cars for my grain elevator. I built Fergus Fine Foods with the idea of box cars on doors 1 and 2 and a 50 foot insulated box car on door 3, so I usually try to stick to that.

That’s it. Away you go and start banging the freight cars around until you have everything spotted where it should be and all the “X” cars lined up on the inbound/outbound. Due to the lack of run-around space I specify that the engine does not need to lead the cars but may push cars out of town.



## 7. Spotting a car at the “to be built” Wilson Coal Merchants dealership.

At the end of your operating session, take away all the car spot markers, shuffle them up and start all over again. With 19 freight cars on the layout it works well, being quick to set up and interesting to run, taking over 60 minutes to complete each session. Even better, you can leave an operating session half way through and it doesn't matter as the markers will still be there when you come back.

### Getting the X's Right

The only issue is getting the right number of “X” markers. I use six “X” markers as my inbound/outbound track holds seven 50 foot or eight 40 foot cars plus loco. Using six “X” markers means I always have at least one or two spaces spare on Track 2 which due to the lack of other space doubles as a make-up track.

### Refinements and adding further interest

1) For some reason I created a 3A car spot at Fergus Fine Foods. I don't know why, but there is nothing stopping you



from doing so without having to re-label all the car spots again. The rationale I used was that it is where the odd tank car or grain hopper would be spotted to unload into silos. However, it is now part of my plan and has boosted the number of car spots to 17.

2) With spots 7, 8 and 9 I envisioned a grain elevator so the actual order of the cars is immaterial. Thus, I created three car spot markers numbered 7/8/9 which is the three car spots together in any order. This accidentally solved the problem of confusing 9s and 6s.

3) Whilst I don't block the outbound train ("X" marks) I have added a little wrinkle in the system. I now have four "X" plus an

8



## 8. Bob and Fergus inspect the waybill for the tanker.

“X1” and an “XE” marker. X1 means the car must be coupled to the locomotive and XE means it must be at the far end of the outbound train.

4) Fergus Fine Foods operates 24/7 with staff loading and unloading cars and so are a bit concerned about other freight cars on their spur. Thus I have created the following local rules:

- a) Where possible, Fergus Fine Foods (FFF) will be switched first.
- b) Due to FFF staff working loading and unloading cars, the speed limit on the FFF track is 5 miles per hour. The bell must sound for the duration the loco is on the spur.
- c) Only FFF freight cars are allowed on the FFF spur and no other cars may be spotted there, even for a short duration. This effectively reduces the amount of switching space available to the local.

## Plans for development

As I enjoy switching cars, I will develop a car card system for this layout. This would be relatively easy to do with the car cards simply having a single number on them to match the car spots. When spotted, turn over the card for the next spot.

Finally, I am starting on my permanent layout and the initial benchwork for the first portion is in. It is a staging and classification yard which will connect directly to Kayton by straightening out the inbound/outbound track to run parallel to Fergus Fine Foods. This will extend the life of the Kayton Short Line until I finally dismantle it to make way for the next expansion.



contents



index



Robert Douglas received a Triang-Hornby train set as a boy in England, sparked a life-long interest in trains. He quickly became fascinated with American railroading but life and family called, resulting in a 30 year hiatus.

A mere three years ago, after trying N scale he moved back to HO and the Kayton Short Line is his first operating layout. Robert is a member of the North Shore Model

Railway Club in Auckland, New Zealand, and enjoys meeting fellow modelers and operating on their layouts. Prototypical operation has become his latest interest.

To pay for his train obsession, Robert is an IT manager for a state high school. He and his wife, Kay, have two adult daughters, the oldest of which is also a member of the NSMRC. More recently they gained a son-in-law and a grand-dog and are looking for a new home with a larger railroad room!



***Want to keep  
MRH free?***

***Then become  
a subscriber.  
(It's free)***

*You provide your email so we can send you weekly updates. We don't share your email with anyone, ever.*

***Hobby vendors look closely at our subscriber number to determine if they want to advertise with us.***

*Click here to become an MRH subscriber.*



contents



index

# An introduction into 3D modeling

Taking advantage of new technology ...

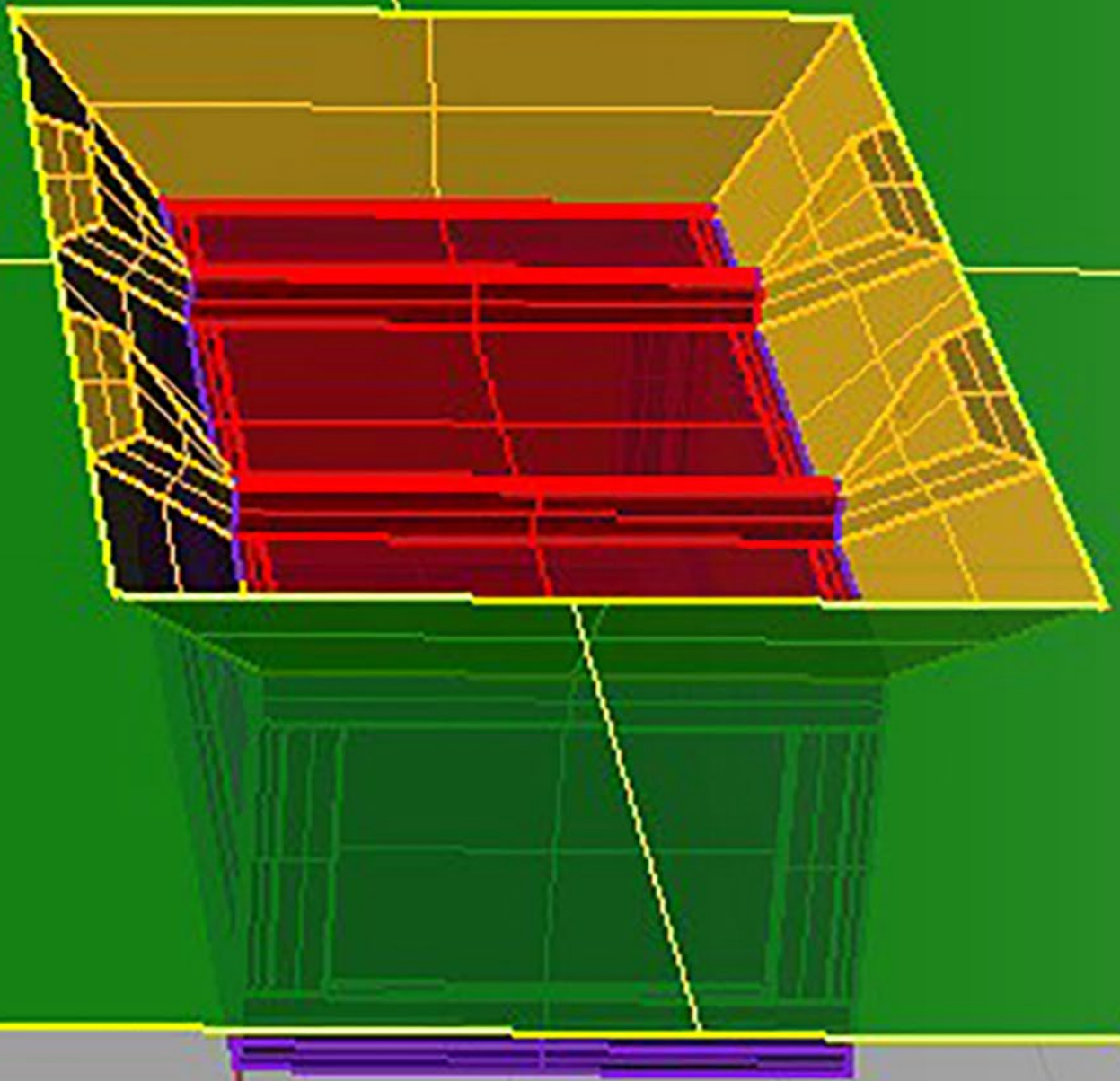

– by **Earl T Hackett Jr.**  
Photos by the author





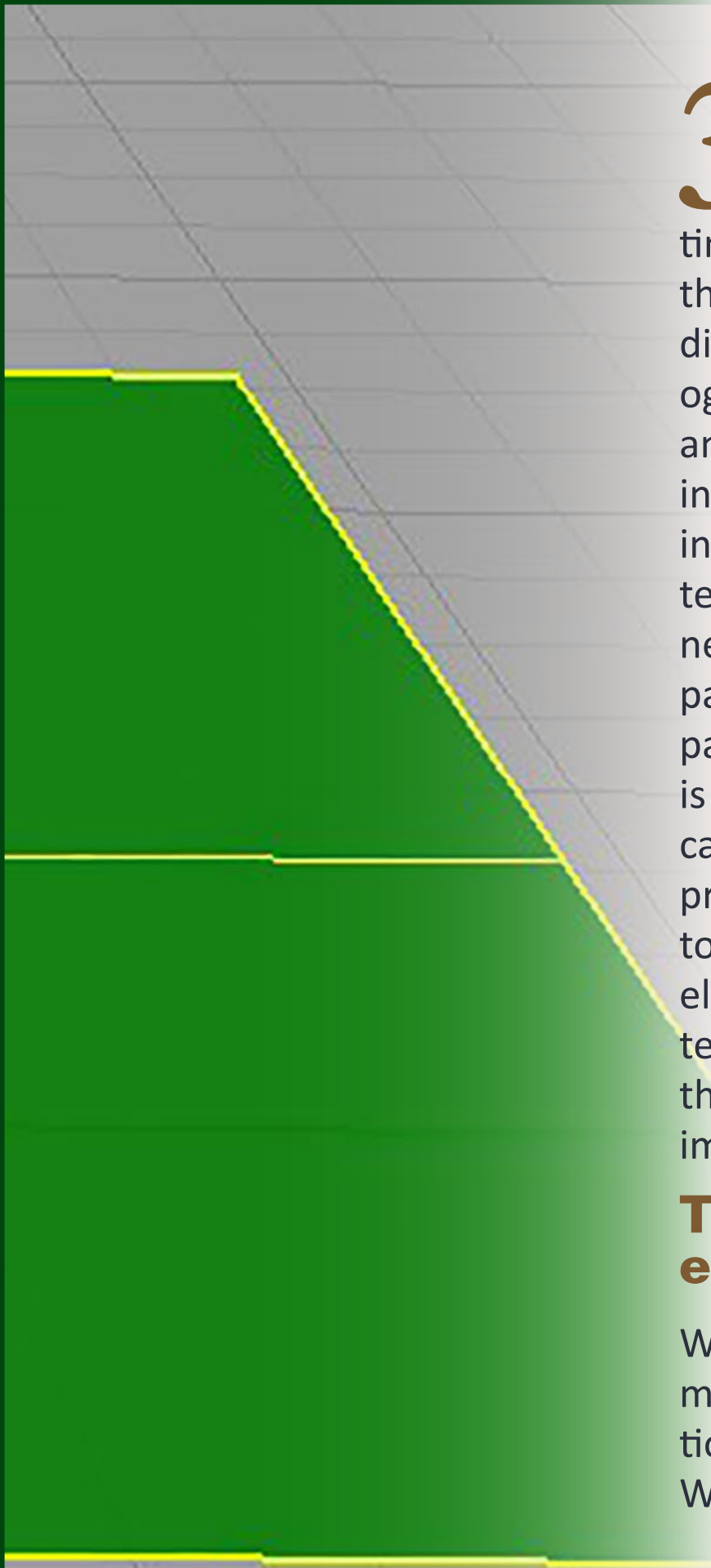

3D printing has come a long way in the past few years, and it may continue to improve. However, the surface quality of today's digital printing technology is far below that of CNC and traditional model making. Additive manufacturing, as 3D printing is usually termed, is useful when you need a quick demonstration part, or the cost of making a part by traditional methods is prohibitive. The final part can require significant post-production surface treatment to provide the finish we modelers expect. However, this technique can produce parts that otherwise would be impossible.

## **The beginning, an experiment**

While planning to build a model of the passenger station at White Sulphur Springs, WV, I found it had a number



**Reader  
Feedback**  
(click here)



contents



index

of custom windows that would be difficult or impossible to build with conventional methods. Fortunately I have a small mill and lathe with digital readouts, and I set about developing what I call my “lost wax” mold making process. For windows with straight lines, it worked well, but it ran into trouble making curves. A CNC mill would take care of curves, but I’m not too keen on spending \$8000 for one. Although the quality of the parts produced from molds created by my machines is excellent, it has a couple of problems – you only get one mold and it is difficult to provide pathways to vent excess resin.

I have been watching the development of 3D printing at various trade shows. It has been slowly getting good enough for modeling. Then at last summer’s C&O Historical Society



**2. This is the mold box and the mold it produced used to make the door. You can see where I glued a piece of plastic sheet to repair the broken wall.**

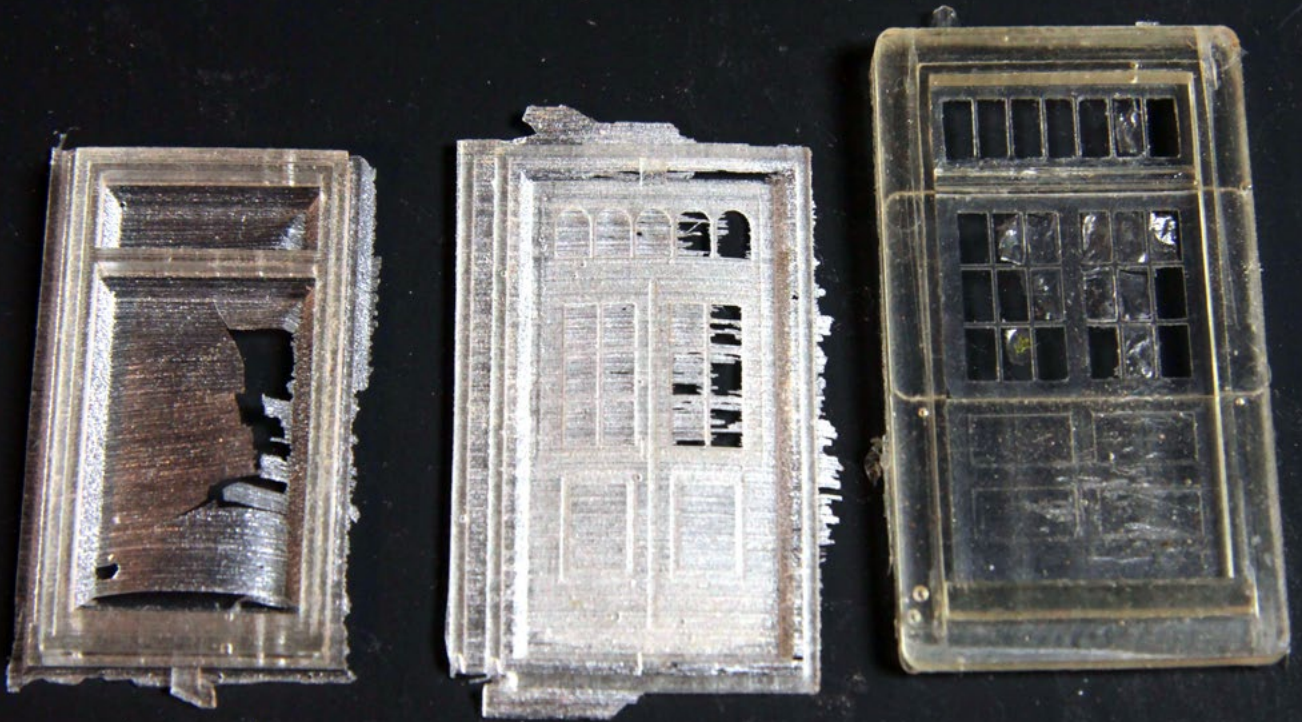

**3. Epoxy castings of a door and frame from an RTV silicone mold produced from a 3D-printed mold box are on the left. A freight door cast from an RTV silicone mold made from a machined mold is on the right.**

convention, one of the presentations was on making models with this technology, and the resulting small structure models looked very good. I decided to try it on a door with arched windows in the transom that had been giving me trouble.

I made a 3D model of the door and frame and sent it to Shapeways [www.shapeways.com](http://www.shapeways.com) to be produced in their Frosted Ultra Detail (FUD) plastic. Although this process produces the finest detail available today, I soon got a reply that they couldn't produce the fine detail I was asking for. The window mullions are 0.01" (0.25 mm) wide in HO, and the material was too weak to support free-standing elements of that size. I can easily cast details of this size, so I decided to try something different.



The positional accuracy of the system is quite good, about 0.2% or 0.002” per inch. So rather than make a master from which I would create a mold, I decided to make a mold box that would produce the mold directly. I asked the Shapeways technical people if anyone had ever done this and the answer was “No, never.” It would be an inexpensive experiment so I went ahead and gave it a try.

Overall, it worked pretty well, but there a couple of things to watch. First, contrary to advertising claims, the surface is not smooth. It feels smooth, but there are little grooves between the rows of deposited plastic. Silicone rubber won’t stick to the plastic, but it gets trapped in these grooves and is very difficult

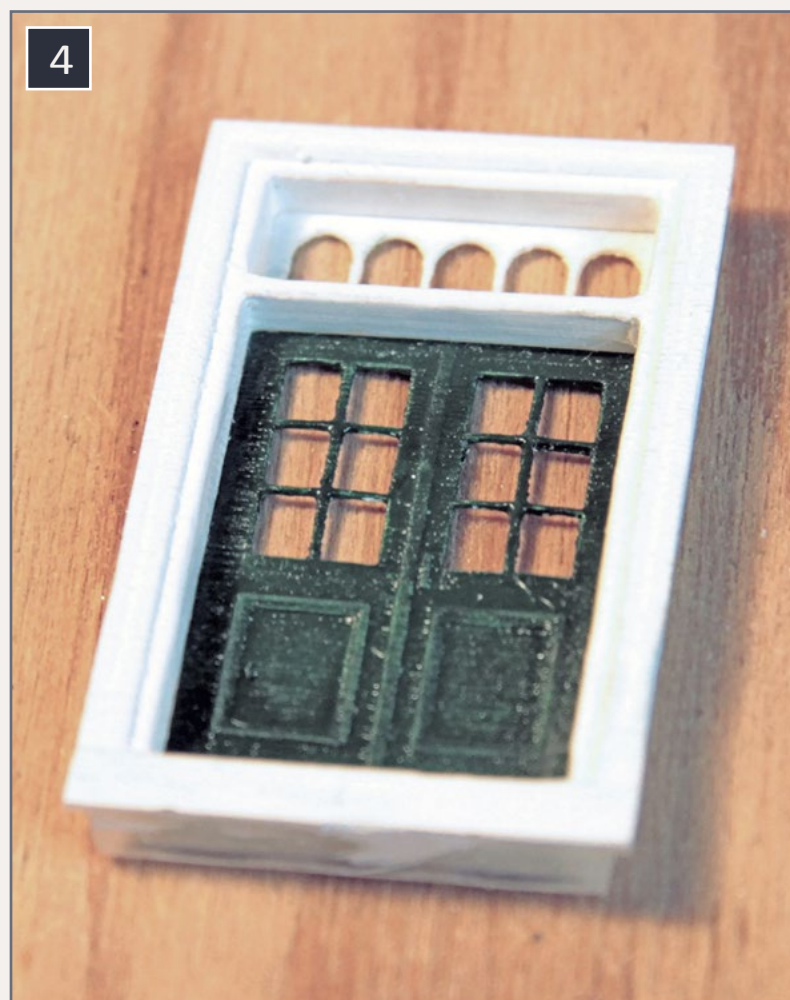

#### **4. The door, painted and assembled.**

to remove. I broke part of the mold box prying the RTV silicon from the bottom of the box. The surface finish on parts from this mold made them essentially useless. Things couldn’t get any worse so I applied a coat of gloss finish to the mold to fill these grooves, and the second attempt at making a silicone mold worked well. Two coats of gloss finish would probably be better, but you have to be careful not to obliterate the detail.

[2] shows the mold box and the mold it produced used to make the door.

These castings [3] are shown in their as-cast condition. The door and frame from the gloss-coated 3D-printed mold are on the left. The horizontal lines left by the print head are clearly visible. By comparison, the freight door on the right was made with my lost-wax mold-making technique. The differences are pretty clear.

With good gates to remove excess resin, the flash is very thin and easily removed with a modeling knife, a problem difficult to solve with my machined mold. I included a recess in the back of the frame that aligns the door for accurate assembly. This example was brush-painted and, although it looks fine to the naked eye, on close examination you can see problems associated with the rough surface left by the printhead. An airbrush might produce a more uniform finish. I am still experimenting with methods to produce a smooth surface without damaging the details. However, I was so pleased with this that I thought other modelers should look into this technique.

## **3D CAD Software**

You need 3D CAD software. Google SketchUp, is probably the best-known free program. The Sketchup program and available freeware has changed since the 2013 version. Tools for arcs and circles are limited, but available in the standard toolbar. An export extension for .stl file export no longer exists. Thus options have been significantly reduced in the free CAD universe. Until recently I've seen no reason to purchase the Pro version for \$500, but with these changes you may want to consider it. In its basic form it is pretty useless, so you have to load up a bunch of plugins. From the Window/Extensions



contents



index

Warehouse you will need 1001bit Tools. Shapeways will accept Collada files for part production.

Another free CAD program is FreeCAD. If you want to purchase a commercial CAD package, I recommend Rhino, which I currently use, at \$1000, \$1300 with the Flamingo render engine. It has an excellent help system which also serves as a good tutorial. My favorite is Ashlar Cobalt because of its excellent user interface. It is more expensive (\$2500), but less so than AutoCAD (\$4500). Finally. ProgeCAD is a relatively inexpensive AutoCAD-like program. The basic package sells for about \$500. I've never tried it, but it looks good on paper.

## **Creating 3D Models for Printing**

A model intended for use in 3D printing is more involved than one intended as an engineering drawing because of some added requirements.

### **Objects must be closed**

In a CAD drawing, a solid is not a solid, but a volume encased by a set of continuous surfaces. To achieve this, all the surfaces must join continuously along all the seams. There may be no holes in the surface and no naked edges. A tiny bit of a surface sticking out beyond another surface will cause an error when exporting the Collada file used for 3D printing. Finding the source of the problem isn't difficult with most CAD systems, but it can be time consuming if there are a lot of these errors.

### **Objects must be manifold**

In simple terms, where any surfaces join, there can be only two surfaces. In two dimensions, a T is not manifold, but an L is. This problem sneaks in when you're adding details to a larger structure. For example, if you add rivet detail to a flat surface, you have to delete the portion of the flat surface that the rivet

covered, and you can't leave any holes. It can be difficult to spot these errors because they are often hidden in the interior of the model.

## **The Normals for all surfaces must point outward**

This is not something you would normally think about. In 3D model construction, surfaces have a front side and a back side. You can't see it in the rendered model, and for an engineering model it doesn't matter. If you create a 'solid' figure such as a sphere or a cube using a CAD tool, the normals will be facing outward, the proper direction.

However if you create a solid object from individual surfaces, the normals will face in the direction determined by the order in which you draw the points. Once you figure it out, you get in the habit of drawing the edges of the surface in the proper order. If you use existing surfaces to create a new surface, there's a problem.

For example you have drawn four sides of a cube and you want the program to put a top on it using the edges of the existing sides, the direction is determined by a mathematical formula not obvious to the user. You have to ask which way it's facing, and there's the rub. Rhino, the CAD system I use, shows little arrows. That's fine for a few surfaces, but what if you have hundreds of them? There's a forest of arrows and it's darn difficult to find the ones that are pointing the wrong way. So I have to go over the model in great detail, inspecting 10 or 20 surfaces at a time. The interface makes it as painless as possible, but it still takes time.

## **Other limitations**

Keep in mind the minimum dimensions and the working volume. Depending on the material you use, there are minimum



contents



index

wall thicknesses and free-standing wire dimensions you must adhere to. You will be billed by the volume of the part, so you want to keep your wall thicknesses as thin as possible. Also note that there are physical boundaries in these machines. You can not make a part that won't fit in the working volume of the machine. Machines that produce more-detailed parts usually have a smaller working volume.

These printed parts are made by polymerizing a liquid or applying molten plastic one layer at a time. In both cases the material shrinks as it solidifies. As a result, flat surfaces warp, sometimes quite badly. Wherever possible, add stiffening ribs to minimize this warping. This would be a serious problem if we were making a precision part.

NOTE: The SketchUp interface does a good job preventing you from screwing up manifold and normal vector requirements as you create the model, making it the best CAD package for beginners. This doesn't mean it's perfect. If you do manage to screw-up the manifold or normal requirements, the Cleanup plugin will help you find and eliminate them.

## **Drawing in 3D Using SketchUp**

I didn't start off intending this to be a tutorial on using CAD systems, but that's how it wound up. I'll provide a little help to get you started in SketchUp. Once you see how a few of the tools work, the rest become pretty obvious. The SketchUp interface prevents many of the above-mentioned problems. If an object isn't closed, it deletes the surfaces so you can see the problem. It creates 3D objects by drawing a surface and then dragging it into a 3D shape. This allows the software to control the normals and prevent manifold problems. For anyone new to drawing in 3D, this is a big advantage.



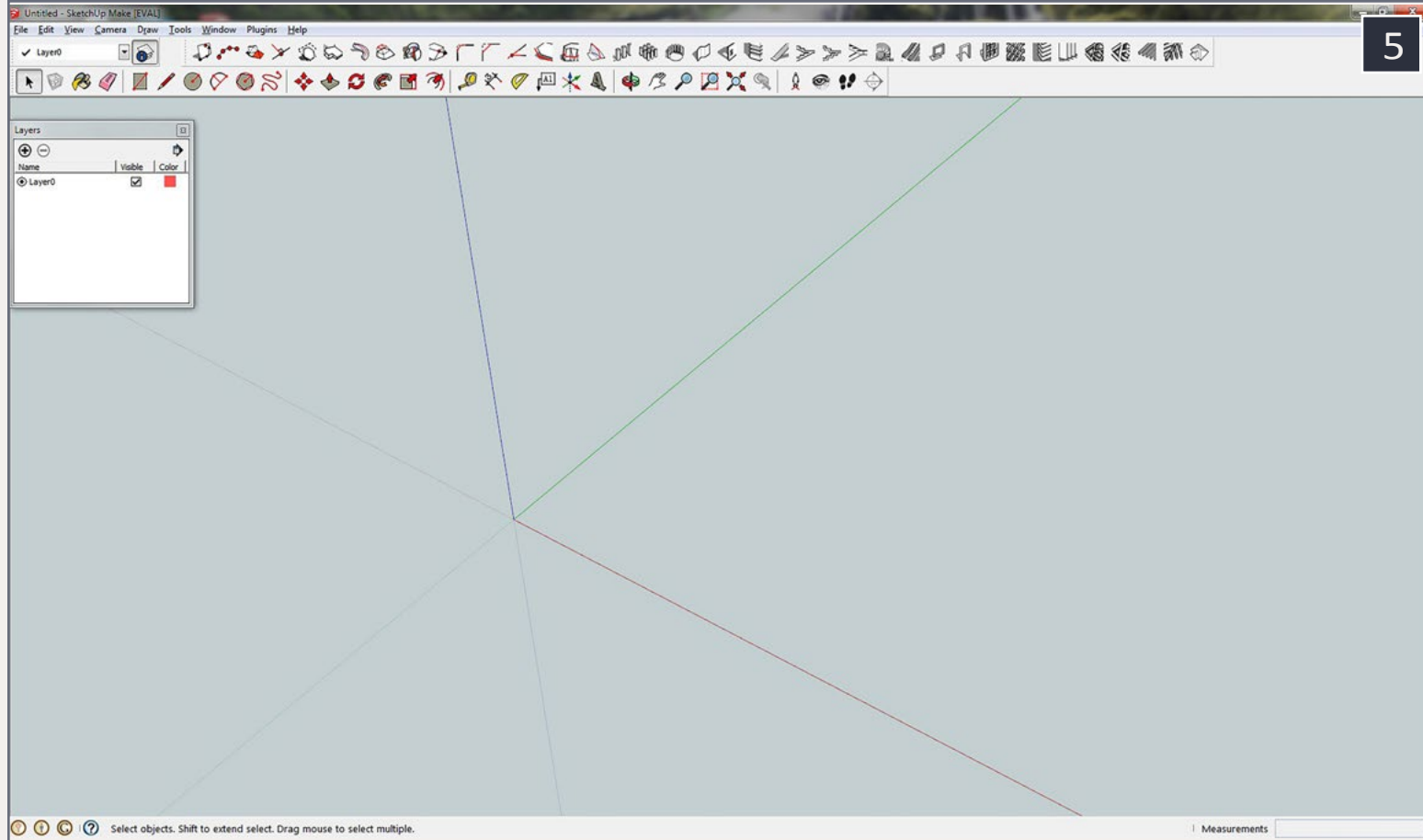

## 5. The SketchUp start screen

When you first start SketchUp you have to select a template. I selected the inches “Woodworking” template. If working from an old set of drawings in feet and inches you may want to use that template. I prefer to work in just inches. You can draw in the scale of your choice, but professionals draw the basic shape full size and then shrink it down to the proper scale.

Download and install SketchUp Make, the free version. In the View menu open the Toolbars window. Select the Large Tool Set, Layers, Solid Tools, and Standard toolbars. You can uncheck the Getting Started toolbar. After installing the plugins the screen will look something like [5].

## The SketchUp start screen

I moved the icons for “1001bit Tools” to the top toolbar. Cleanup is in the Plugins menu, “Arcs and Circles +” is in the Draw menu, and Collada File is in the File menu. To see what the various tools do, hold your mouse cursor over the icon and



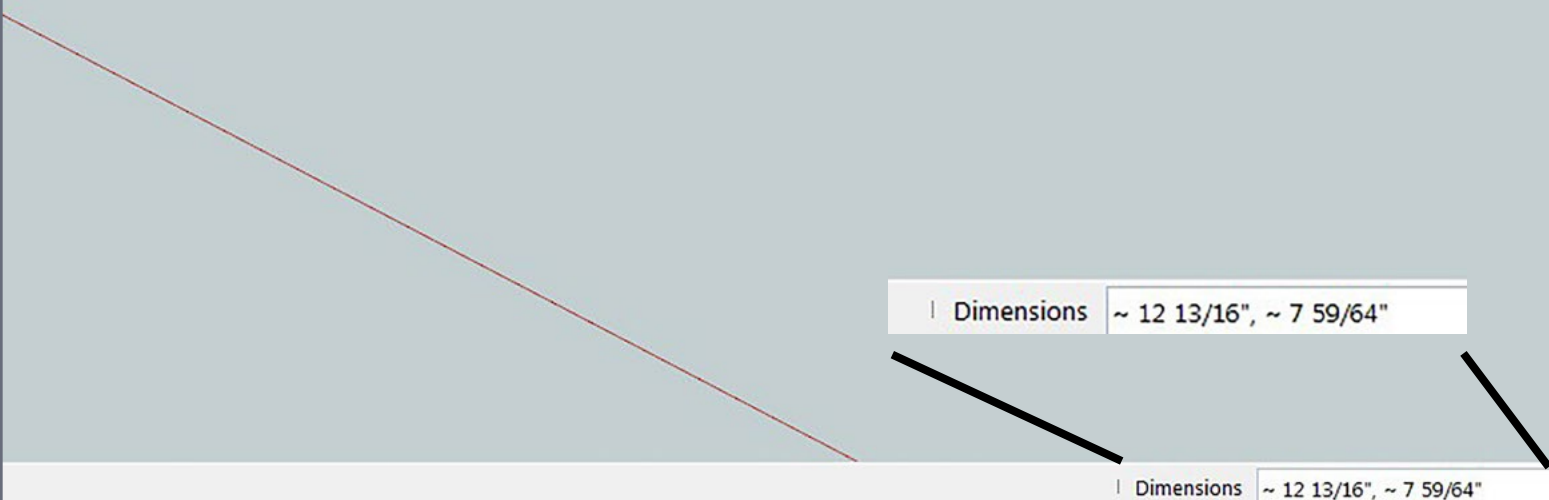
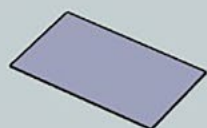

## 6. Start of Rectangle; note the dimensions in the lower right corner

a description will pop up. To illustrate how SketchUp works, I'll walk through the creation of a shipping crate.

Select the rectangle tool, click and hold at a point in the drawing area, and drag the icon a short distance. A small rectangle will be created. The dimensions of the rectangle will be displayed in the lower-right corner.

Now type the dimensions you want (48,80, the size of a large shipping crate). Press Enter and the rectangle will be adjusted to the desired size. You do not type in the Dimension box, just hit the keys and SketchUp will handle it.

Pick up the Push/Pull tool, select the rectangle, and pull it up. The distance is not critical, just start the movement. Type the desired distance "36 Enter," and the basic shape, a box 48" x 80" x 36", will be created.

7

The size of the crate is now set. This is how all objects in SketchUp are created. A shape is drawn on any surface and then it is pushed or pulled as desired.

This is a good time to play around with the view tools: Orbit,

## 7. The basic crate shape, 48" x 80" x 36"

Pan, Zoom, Zoom Window, and Zoom Extents. If you have a mouse wheel, you can use it for zooming in and out.

Now to make it more interesting, put some 2x4s around the edges for reinforcement. You could use the rectangle tool, draw rectangles on the faces and pull them out, but there's an easier way. Select the Offset tool, click on a the vertical long face, and start to drag a copy of the rectangle (this works with any shape). Once you have started the rectangle type "6 Enter" and you have a 6" border. This accounts for the width of the 2x4 plus the thickness of the 2x4 on the adjacent faces. Now take the Push/Pull tool, push the center rectangle in, and type "2 Enter." The result is seen in [8].



contents



index

Repeat for the opposing side and top using appropriate offset distances. The ends are a bit different. The top and bottom stiffeners should be 6" wide, but the sides should be 4" wide. To do this use the offset tool and create a rectangle with a 6" offset. Take the Move tool, click the right side of the inner rectangle, move it slightly to the right, and type "2 Enter." Similarly move the left side 2" to the left. Push it in 2" and you have as seen in [9]

Repeat on the other end to finish the model.

You could export a Collada file and have a model made, but you pay for volume and a solid model costs more. So we want

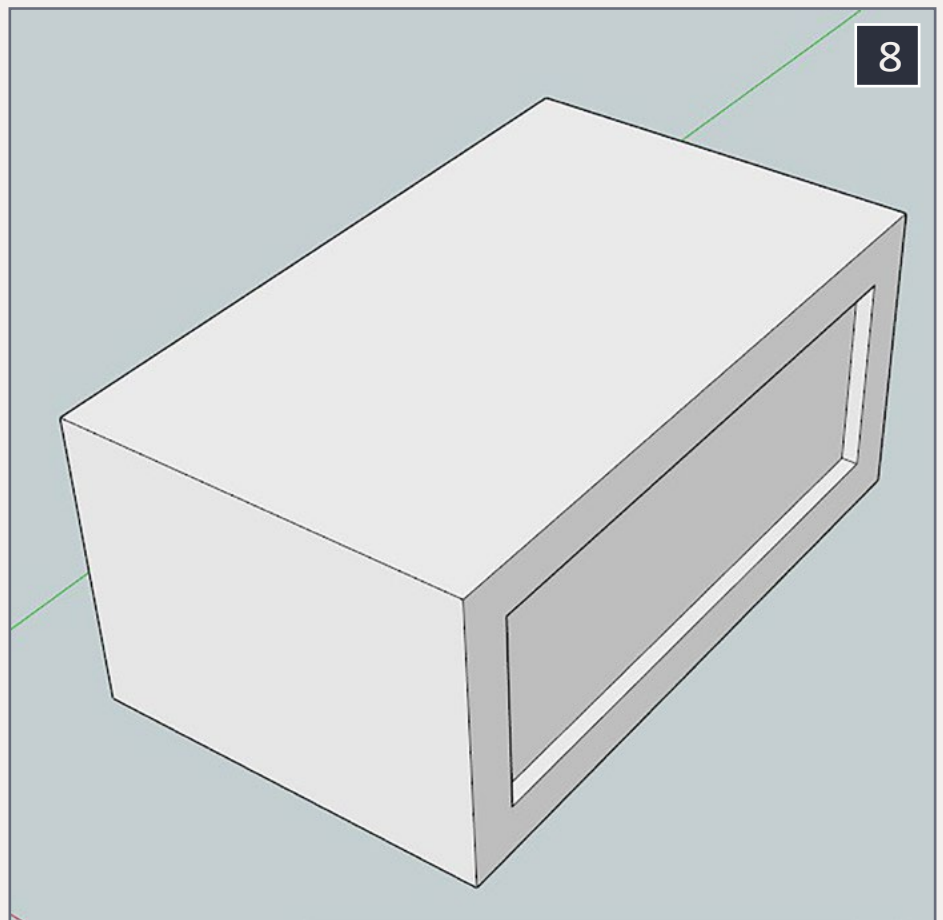

**8. Crate with one side done.**

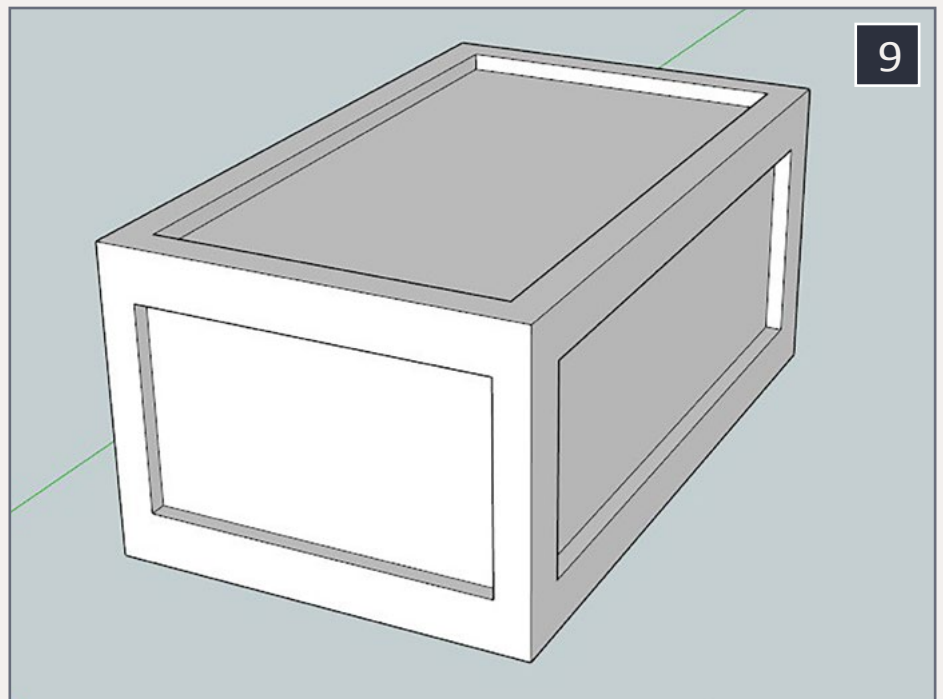

**9. The finished crate.**

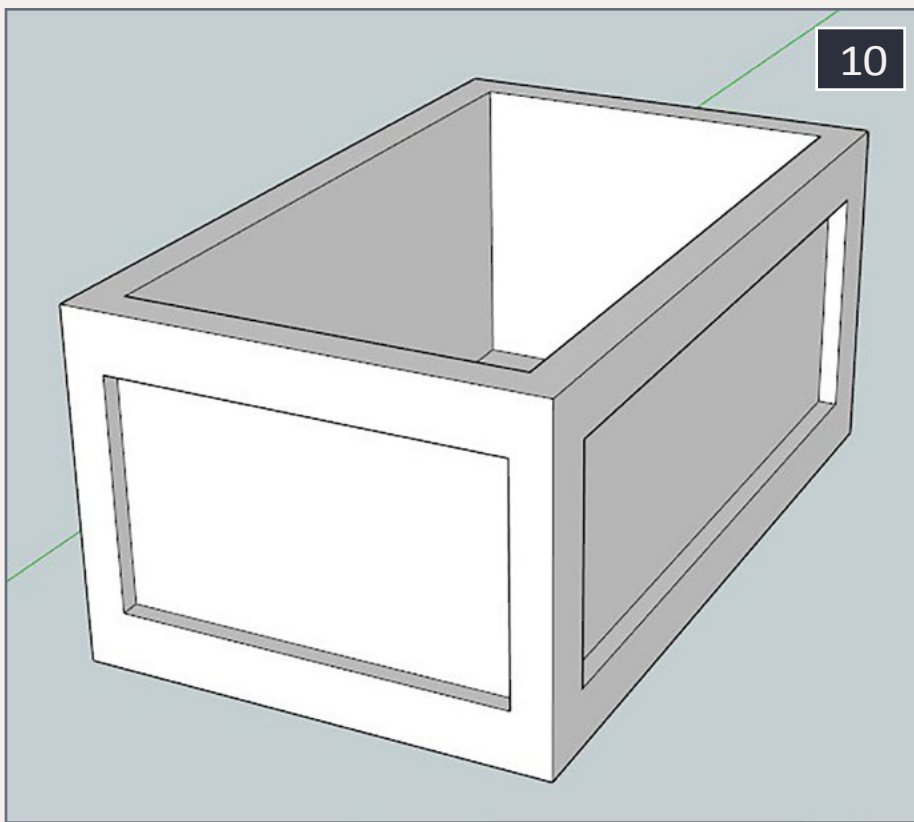

## 10. A hollow crate.

to make it hollow. I use Shapeways “Frosted Ultra Detail” resin that requires a minimum wall thickness of 0.5 mm, about 2” in HO scale. In this case it’s easy. The edges of the top recessed rectangle are 2” inboard from the side recesses. The overall height of the crate is 36” so the top and bottom recesses are 32” apart. So just push the top recess down another 30”.

Let’s put a couple of 2x4s on the bottom to stabilize the sides and so a fork lift can get its forks under it. Construct a 2x48x4 box away from the crate. Select the entire 2x4 by making a rectangle around it and with the Move tool, pick a corner and move it so “On Edge” appears. There are a number of positioning aids available. They automatically appear when the alignment is close. I tried to capture them, but they do not appear in the screen shots. The select tool is a bit different; once the part is in the right location hold down the shift key to lock it in place until you pick another tool. Otherwise the part just keeps following the Move tool. Use the Select tool to select the 2x4 and copy it using “<ctrl> c”. Move it around until “On Edge” appears (make sure it’s the right edge) and release it. You want something that looks like [11].



contents



index

Just one more step – scale it to the desired size. Select the entire crate and with the Scale tool move one of the handles to make it smaller and type “0.01148” (that’s 1/87.1, but SketchUp doesn’t understand fractions) to reduce it to HO scale. It will reduce to a tiny speck on the screen so use the “Zoom Extents” tool to see it. I like to move it so the sides line up with the drawing axes. Some older software requires that the model be positioned in this way or it tries to print it out in space. With it at the origin, there won’t be any problems.

Now we can play with one of the cool tools, the Section Plane. Pick it up and click one of the surfaces of the crate. The green tool will turn into an orange rectangle that creates a cut-away section of the crate. Select it (it turns blue) and use the move tool to move it through the crate to see any section you like. This is useful to check that you meet minimum wall thicknesses.

Now just go to the File menu, Select “Export Model/Collada File. Say OK to the defaults. All software packages accept

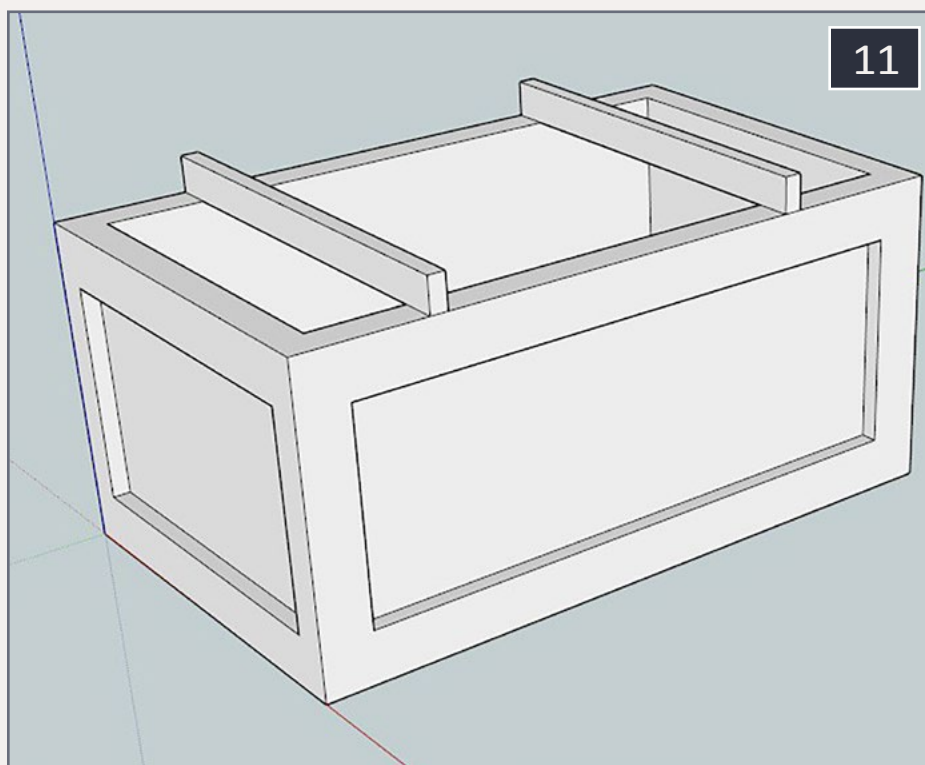

ASCII data and it must be exported in the same units as you drew it, in this case inches, or it will change size. E-mail the Collada file to Shapeways and in a few days you’ll have the physical part. You can use the

## 11. Crate with 2x4 spacers.

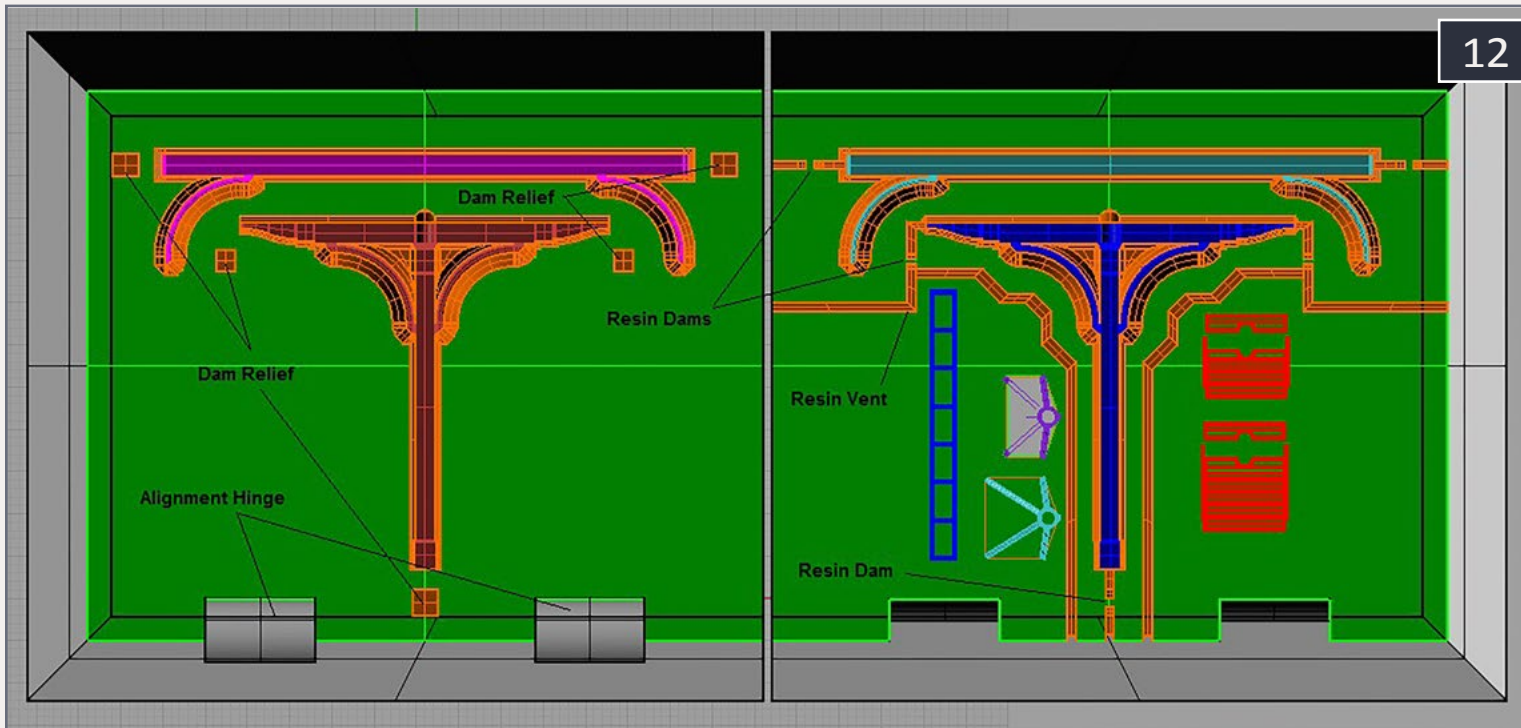

**12.** This is an example of a mold I made using Rhino. Once the box is printed, I apply a gloss finish to smooth out the mold. I then pour mold material into the box creating my mold as shown in [2]. This goes beyond the scope of this article, but I have shown it so you know it can be done.

part directly on your layout or you can use it to make a mold and make bunches of parts. To use this model as a master, fill it with epoxy resin and then continue with conventional clay mold-making techniques.

We have been working in the default perspective view. Things are getting more complex, and I prefer to select Parallel Projection in the Camera menu. Well, that's it for the SketchUp tutorial. You're on your own to explore all the various SketchUp tools.

## Conclusion

What I have shown is just a basic outline of 3D modeling. Although this not a perfect solution to building custom models,



it is pretty darn good. At the present time I would not use it to produce a steel box car because the poor finish would be very obvious on a large flat surface. If you are creating a wood-sheathed maintenance shed, if you align the wood planks in the proper direction, you get the wood grain for free.

If you want a smooth roof for a passenger car, particularly one that has compound curves, you can make it a few thousandths of an inch oversize so you have some material to remove with 320-grit sandpaper, thus producing a very fine surface finish. Once the surface has been smoothed, detail parts can be added.

An excellent use for this technology is for models consisting of a lot of small structural parts, such as a signal bridge. I'm currently preparing drawings for a large C&O cantilever signal bridge. Using small magnet wire, I can put the electrical connections inside the larger structural members, and the rough surface finish will not be noticed on the small parts after being painted flat black.

There is a stereolithography technology available from 3DSystems that has significantly better resolution than the Shapeways FUD, but it is also about 10X as expensive. My design for a C&O large cantilever signal bridge would cost \$500 – well beyond my price point.

SketchUp is OK for simple projects, but more complex models will require the purchase of a 3D program like Rhino or Ashlar. If you are a first time user of 3D software, practice on something simple. There is a steep learning curve.







Earl Hackett has lived on the East Coast except for a few years in the Air Force. When he was an infant we lived a few blocks from the mainline Baltimore & Ohio station in Wilmington, DE, long ago torn down. Approaching the station from the south there is a steep grade. When the steam engines hit that grade they would often slip. Earl said, “When my

mom heard the slipping she’d toss me in the buggy and run down to the station. We’d get there just in time to see the smoke belching monster come roaring through. This scared the daylights out of me, however, I have had a love for all things steam powered ever since.”

Earl a retired DuPont chemist and very loosely models the Chesapeake & Ohio from Ronceverte to Allegheny summit in October, 1952. He scratchbuilds almost everything and is constantly experimenting with different materials and techniques, so the going is pretty slow. He has a collection of metal and wood working machines and to him it’s more about the journey than the destination.



contents



index

# Mike Confalone's ALLAGASH STORY

## 4 volume eBook series

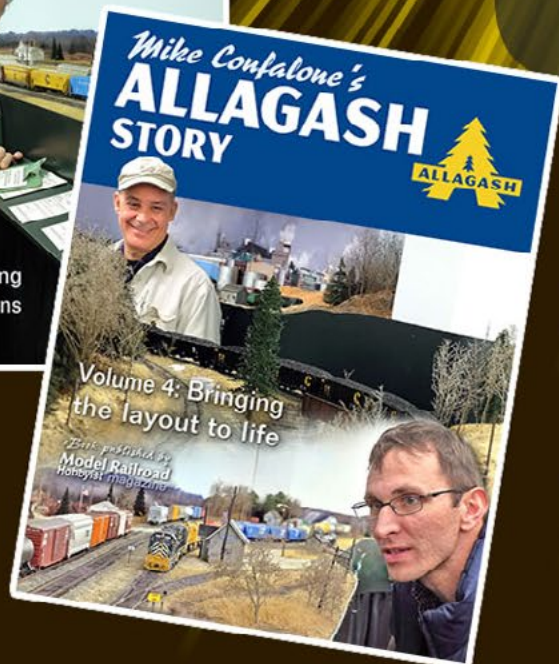
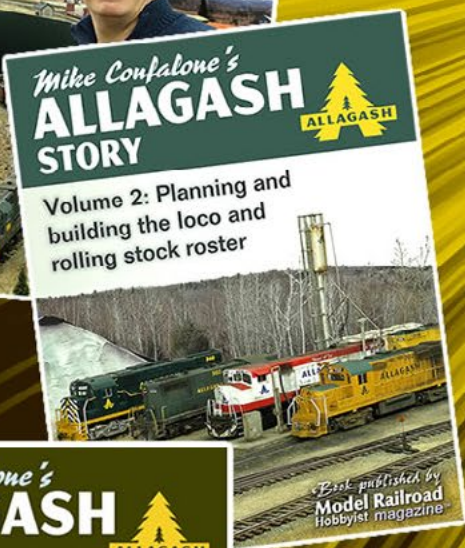
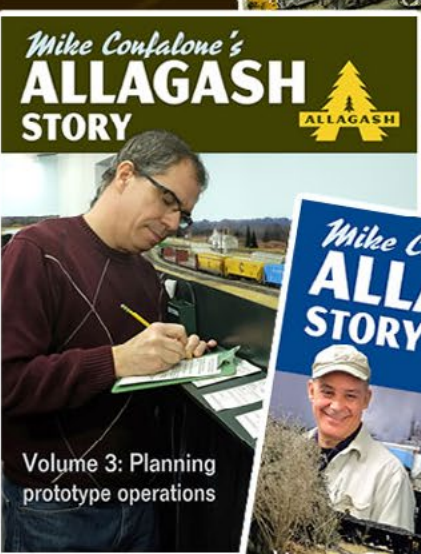
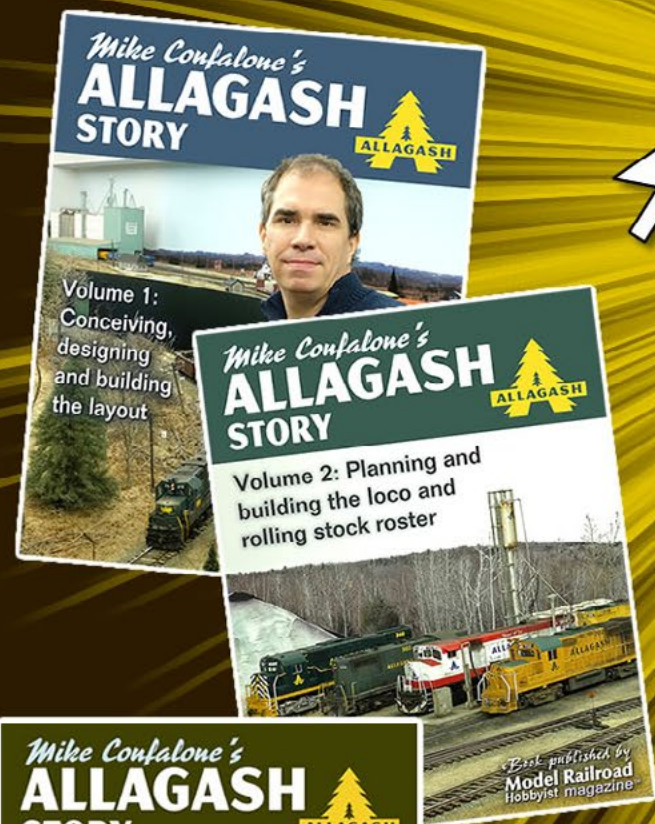

Formats: PDF - ePub - Kindle

 **Order Allagash Story**

- Vol 1: Building the layout**  
Now available - \$8.99
- Vol 2: Building the roster**  
Now available - \$8.99
- Vol 3: Planning prototype ops**  
Now available - \$8.99
- Vol 4: Bringing the layout to life**  
Mid-May - \$8.99

**4 volume set: ~~\$35.96~~**  
**Special: \$29.99**

from the  
**Model Railroad  
Hobbyist** *Store*





# N scale SP&S Alco RS-3

A hobby store and Atlas combine efforts

by Joe Brugger



Reader  
Feedback  
(click here)



1. Two road numbers and a unnumbered engine are available.

**T**he Hobby Smith in Portland, OR, has commissioned from Atlas a custom run from of N scale Spokane, Portland & Seattle Alco RS-3 diesels in the as-delivered tiger stripe maroon and olive green scheme.

The 1600 hp RS-3 was a true multipurpose road switcher and the SP&S acquired a total of 29. Numbers 65-82 were Phase I units delivered from 1950 to 1953. 83 and 84 were the former GN 231 and 232, acquired in 1959, and 90 through 98 were in Phase III bodies, bought in 1955.



Almost all survived into the 1970 Burlington Northern merger, and several received four-digit BN numbers without being repainted. They were routinely operated with other EMD and Alco locomotives on the SP&S, and also often appeared with Great Northern units.

Available are road numbers 95 and 98, as well as an unnumbered version so modelers can add their own numbers. The 95 was the last SP&S engine to be repainted into the broad stripe scheme introduced in the summer of 1964.

The models come with body-mounted couplers, directional lighting, low-friction drive and are DCC-ready.



Well over 1,300 RS-3 road-switcher locomotives were built by Alco between 1950 and 1956. These locomotives were powered by an Alco 244 V-12 engine which was complemented by rugged GE electrical components. Nationwide, the RS-3 could be found in virtually every type of service from passenger and commuter runs to heavy-haul and local freight assignments. ✓

## 2. Lettering follows prototype practice.

# Specifications

## RS-3

Spokane Portland & Seattle  
Road number 95, 98 and unnumbered

## N Scale

### Price:

\$119.00 for one, \$218.00 for two

### Order Information:

The locomotives are available now at The Hobby Smith, and can be ordered by email or phone.

### The Hobby Smith

1809 NE Cesar Chavez Blvd.  
Portland, OR 97212  
503-284-1912

[ron@hobbysmith.com](mailto:ron@hobbysmith.com)

[hobbysmith.com](http://hobbysmith.com)



# Did you see this MRH video?



**A full-sized F7  
cab in the  
layout room?**

**Watch the video now**



contents



index



# The Amherst Railway Society Railroad Hobby Show

Our 2015 Show will be

## January 24 & 25, 2015

Save the dates!

### About The Show

Every year late in January or early in February, the Amherst Railway Society holds its Railroad Hobby Show at the Eastern States Exposition Fairgrounds (The home of The Big E) in West Springfield, Massachusetts. More than 25,000 railfans and public attended the Show each of the past three years.

The event features real life railroads and scale model railroads, historical societies, travel agencies, art shows, flea market dealers, importers, manufacturers and photographers. You have to see it to believe it!



**Click  
to learn  
more ...**



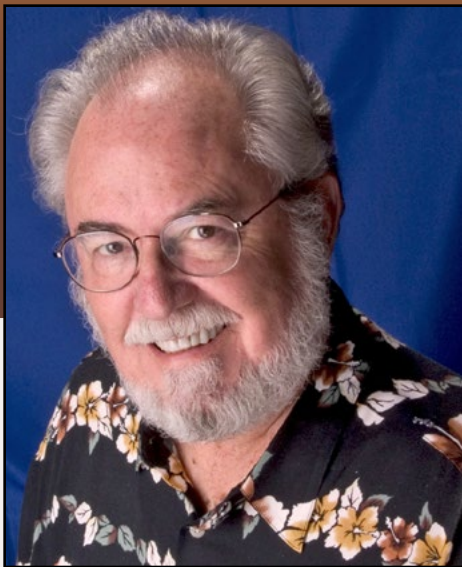

*The Old  
Yardmaster*



**Reader  
Feedback**  
(click here)



## **August 2014: The latest model railroad products, news & events**

*by Richard Bale and Jeff Shultz*

### **Richard Hendrickson 1931-2014**



Dr. Richard Hendrickson, prolific author, noted historian, and long-time promoter of prototype modeling, passed away unexpectedly on June 28. Hendrickson died of a heart attack and subsequent fall at his home in Ashland, OR. He was 83 years old.

A native of Glendale, CA, Hendrickson developed an early fascination for trains in general and more specifically the Santa Fe. As a teenager summering with family in Oceanside, CA, he gained the confidence of a Santa Fe crew who allowed him to drive a 2-8-2 on the branch line to Escondido. Decades later he was still remembering the fun of that seminal experience.

Hendrickson amassed a huge library of photographs and information about American railroads which he willingly shared with manufacturers as well as like-minded hobbyists. In



addition to serving as an inspiration to railroad prototype modeling at meets around the nation, Hendrickson was an active technical consultant to authors and numerous manufacturers of model railroad equipment. A partial list includes Balboa Scale Models, Train Miniature, Life-Like Proto 2000, Walthers, Atlas, Branchline, Kadee, Tangent, and others.

Hendrickson was a marvelously well-informed historian and modeler who authored more than 400 magazine articles on freight car history and modeling. For five years he wrote a column critiquing commercial models in Rail Line News. He authored or co-authored four books about the freight cars of the Atchison, Topeka and Santa Fe Railway, and co-authored “Billboard Refrigerator Cars” with Ed Kaminski. He figured prominently in the creation and development of the current Santa Fe Railway Historical & Modeling Society and its predecessor organizations. Arrangements have been made for his railroad library, photographs, and collection of reference material to be donated to the California State Railroad Museum at Sacramento.

In addition to a compelling interest in railroads, Hendrickson pursued other activities with equal vigor, including fine food, wine, travel, skiing, hiking, bicycling, sailing, and the theater – particularly Shakespeare. He also loved flying and occasionally performed aerobatics in his classic Citabria airplane. He remained interested in sports cars which he raced competitively as a young man.

Hendrickson served his nation during the Korean War as an electronic technician aboard a destroyer. Following his service in the U.S. Navy, he studied at the University of Connecticut where he earned his Ph.D. in English linguistics. His 31 years of teaching at the university level included time at San Diego





State before transferring to Sonoma State University where he and his wife made their home in Cotati, CA.

In addition to his wife, Sandra, Richard is survived by his three children, Graham, Kimberly, and Karin; plus grandchildren Blake and Camile ...

## **Keith Thompson 1959-2014**



Douglas Keith Thompson, a former associate editor of *Model Railroader* magazine, passed away in Maple Valley, WA, on June 16. He succumbed to pancreatic cancer which he had been fighting for more than a year. He was 54. Graveside services were held June 27 at Holly Grove Cemetery in Livingston, TX.

After leaving Kalmbach in 1996, Thompson moved to the Seattle area where he became active with N scale groups. He continued to occasionally write articles and reviews for *Model Railroader*. In the Northwest, Thompson worked as a technical writer for such clients as AT&T Wireless, Microsoft, and Nintendo. A native of Thibodeaux, LA, Thompson is survived by his wife Michelle, and twin daughters Denver and Mikayla ...

## **New Appointments at Athearn**

Horizon Hobby has appointed Chris Palomarez the new brand manager for Athearn. In addition to being a hands-on model railroader, Chris has extensive experience in developing new model railroad products. In other staff changes, Craig Walker has been promoted to supervisor of product development at Athearn ...



contents



index

## **MRC and Model Power establish licensing agreement**

Model Rectifier Corporation (MRC) and Model Power (MP) have entered into a licensing agreement that will permit MRC to produce and market MP's railroad products under the Model Power and Mantua brands which include train sets, locomotives, rolling stock, structures, and accessories. The agreement will insure that MP products will be available to hobbyists worldwide. Blending the various product lines will be under the direction of Adam Tager, who has been appointed to MRC's newly created position of director of product development. Tager was formerly vice president of MP ...

## **National Train Show**

The National Train Show (NTS) is held in conjunction with the annual convention of the National Model Railroad Association. This year's event was held in July in Cleveland, Ohio. Several Model Railroad Hobbyist staff members attended NTS and had the opportunity to talk to suppliers of model railroad products. This month's news report includes information about many of the items shown at NTS ...

---

## **NEW PRODUCTS FOR ALL SCALES**

**BHI Publications** ([quickpicbooks.com](http://quickpicbooks.com)) has several new titles including a photo album on the "D&RGW C-16 #278" that has been on the old bridge in Cimarron, CO for several decades. There are photos both before and after the restoration work and some of the modifications from the pre-restoration version are discussed. The 98-page book includes 221 photos and illustrations. Also available this month are two new books on



Maine narrow gauge: *“Oddities & Mysteries of the Maine Two Footers,”* and *“Sandy River & Rangeley Lakes Caboose 556-558”*. Visit the above web site for sample pages, pricing and ordering information.

---

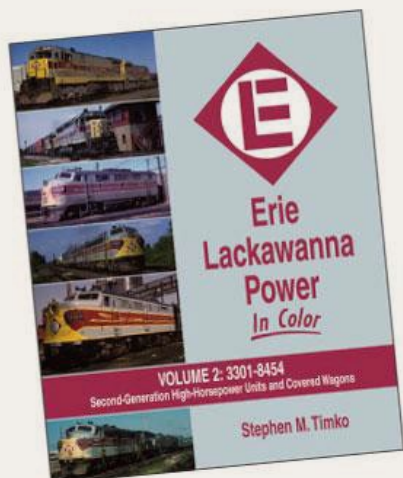

Three new titles from **Morning Sun Books** ([morningsunbooks.com](http://morningsunbooks.com)) include *“Erie Lackawanna Power In Color, Volume 2,”* by former EL employee Stephen Timko. Coverage begins with U33C #3301 and ends with former passenger-equipped F3A #8454. Photos and details are included for EL’s U36C and the New Jersey-owned U34CH units, EMD SD45, SDP45 and SD45-2’s, plus

FT’s, F3’s and F7’s, as well as the Alco 1500 and 1600 horsepower A’s and B’s.

Also new from Morning Sun is *“Southern Pacific Tracksides in Northern California 1974-1996,”* by Ed Mackinson. In the two decades preceding its absorption into Union Pacific, the Southern Pacific was alive with changes. In this volume the author follows the SP’s final activities in scenic Northern California.

---

**RLN Publishing** ([rlnpublishing.com/e-books.html](http://rlnpublishing.com/e-books.html)) is selling *“Commuter Operations for Model Railroads.”* Authored by Bob Nalbene, who is president of The Model Railroad Club in Union, NJ, the book describes how to develop and implement a modest commuter service into a layout’s overall operating scheme. Prototype operations are examined and there is an overview of commuter operations on the well-known club layout. Priced at \$9.95, the 60-page e-book includes photos and illustrations in PDF format.

---



contents



index

## LARGE SCALE PRODUCT NEWS



**Piko-America** ([piko-america.com](http://piko-america.com)) showed several new items at the National Train Show including this 1.22.5 G scale 0-6-0 Camelback steam locomotive

decorated for the Reading Railroad. Special features include ball bearing-equipped 24 volt can-type motor, and ball bearings on the geared driver axle. The ready-to-run model comes with dual-mode SoundTraxx sound decoder.

---

## O SCALE PRODUCT NEWS



**Atlas O** ([atlaso.com](http://atlaso.com)) has scheduled the next release of its 40' AAR 1937 40' boxcar for the first

quarter of 2015. Road names on the single-door model will be Erie Lackawanna (express scheme), Genesee & Wyoming, Northern Pacific (with Main Street slogan), Southern Pacific (1955 repaint), and New York Central.

Also due from Atlas O early next year is another release of its Trinity 25,500 gallon insulated tank car. New numbers for previously released roads include IBPX, ADM, and PLMX. New road names will be Cargill Foods, GATZ (service driven slogan), and





AGP Refined Oil. Visit the above web site for pricing on both 2-rail and 3-rail versions of these ready-to-run O scale models.

---



**B.T.S. ([btsrr.com](http://btsrr.com))** is selling an O scale kit for Cabin Creek Coal Tippie. This is a major complex that, because of its laser-cut construction, is relatively easy to build. The kit consists of laser-cut basswood, plywood, and cardstock, plus a large

supply of brass, plastic, and white metal detail castings. The peel and stick window sash and doors can be installed open or closed. The tippie is served by three tracks. The overall footprint is about 180 x 95 feet. The kit is priced at \$649.95. Visit the above website for additional information.

---

## HO SCALE PRODUCT NEWS



**Accurail ([accurail.com](http://accurail.com))** has released several new kits for HO scale

freight cars including a recently- tooled P-S 4750 cu. Ft. grain hopper decorated for Santa Fe. The triple-bay model has an MSRP of \$18.98.



contents



index

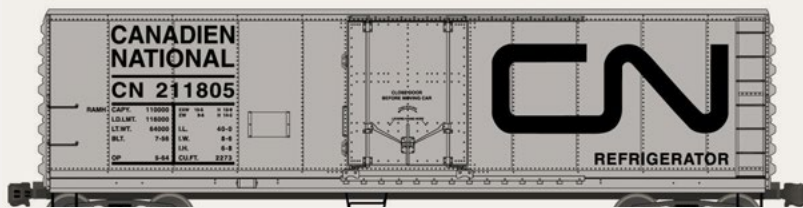

Also new from Accurail is a kit for a 40 foot steel refrigerator car with a plug door, decorated for Canadian National.



This HO scale CB&Q 50' steel boxcar is available in kit form at an MSRP of \$16.98.



**Albrae Models** ([albrae-models.com](http://albrae-models.com)), the new HO scale division of Accucraft Trains, is working on several new projects that will be produced from a combination of hand-

crafted brass, diecast metal, and injection-molded plastic components. The introductory model will be a Southern Pacific flanger as illustrated by the pilot model shown here. Delivery is expected late this summer. Four road numbers will be offered with only 50 of each number being produced. Pricing is expected to be in the range of \$350.00.

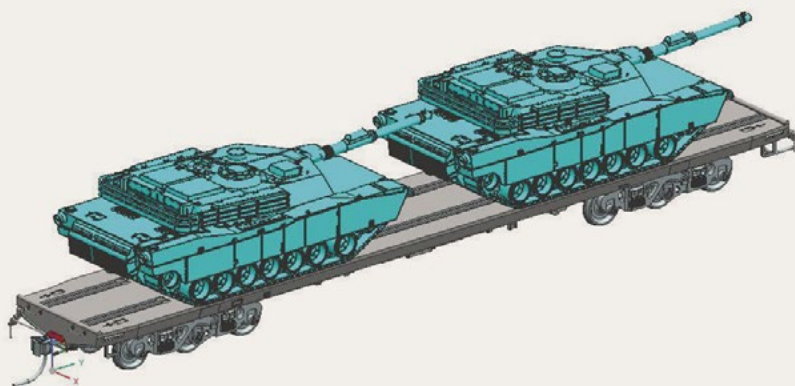

Still under development is an HO scale model of a heavy-duty flat car based on DODX series 40000- 40100 car as built by Fruit Growers Express in

1981. Similar cars were built by Thrall in 1983 and by Ortner in 1985. The model rides on Buckeye six-wheel trucks that will be available separately.

Accurate 1:87 models of M1A1 Abrams tanks are under development and will also be available separately. Visit the above website for complete details or to place a reservation.

---



At the National Train Show **Athearn** ([athearn.com](http://athearn.com)) introduced its new EMD SD40, which is scheduled for release next March. MRH staff member Jeff Shultz snapped this photo of the pre-production sample of the HO scale Ready-to-Roll<sup>®</sup> locomotive.

Although Athearn has had an SD40 in its line for many years, this new version has been completely re-tooled with a new body shell, long hood, roof line, walkways, and pilots. There will be several variations in shell components to permit various road-specific details. For example, several different dynamic brake blisters and non-dynamic brake hatches have been tooled and the side radiator sections have been designed to accept either “chicken wire” or Farr grilles. Different combinations of the sub-base doors, cab, and nose can be tailored to replicate the practice of various railroads.

The frame of the SD40 is sound-ready and will accommodate an SD45 Genesis replacement motor for easier speed-matching to other models. In addition to Union Pacific as shown here,



contents



index

road names on the initial release will be BNSF, CB&Q/Colorado Southern, Chessie System/Western Maryland, Duluth Winnipeg & Pacific, and Norfolk & Western. Athearn's new SD40 with SoundTraxx Tsunami sound and decoder will have an MSRP of \$184.98. Standard DC models will list at \$134.98.



Athearn's NTS announcements include a new BSC F89F 89' 8" flat car with a Whitehead & Kales bi-level auto rack. The

newly-tooled model represents a car built by Bethlehem Steel Company beginning in 1965. Road names will be Chicago, Burlington & Quincy; Illinois Central, Norfolk & Western, New York Central, Frisco, and Wabash. The Genesis series model is scheduled for release next March at an MSRP of \$49.98.



Athearn plans to release its Genesis GP15T/ GP15-1/ GP15AC next

February in several interesting schemes including the Apalachicola Northern GP15T shown here.



GP15-1 units will be available for Conrail, GATX Rail Locomotive

Group, and Burlington Northern.





Also in the mix is a GP15AC decorated for Union Pacific (UPY).



The HO scale Genesis series models feature details unique to each road

name. Each name will be available in three different road numbers.



Also scheduled for release in February is a run of Athearn's Genesis SD70ACe diesel locomotives. In addition to the Montana Rail Link unit shown here, the Genesis series model will be available decorated for BNSF (swoosh scheme), Canadian National (noodle scheme on ex-EMD demo), Union Pacific, and FXE Ferromex. Three popular NS Heritage schemes will be rerun, including RDG, Virginian, and Jersey Central Lines.

A second production run of Athearn's GATX Tank Train equipment is scheduled for release in February. The run will include



contents



index



early (1977) decorating schemes with large Tank Train lettering and late (1982) schemes with smaller lettering.

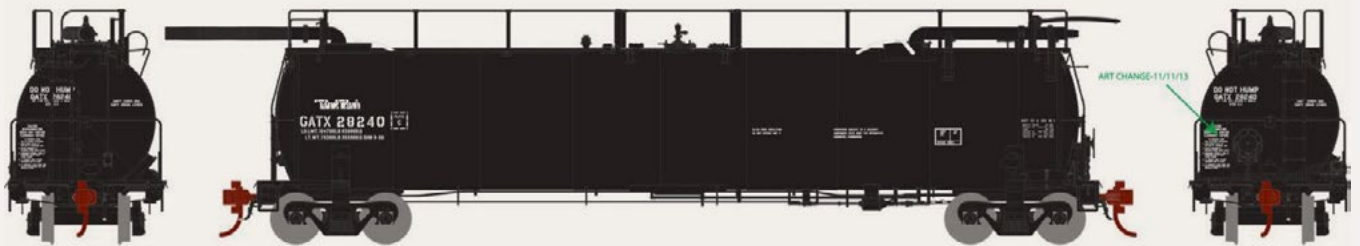

A-end and B-end cars will be available in sets at an MSRP of \$99.98. Intermediate cars will be available in six numbers at an MSRP of \$49.98 each.

Athearn's Ready-to-Roll line HO scale GP40-2 will be released in February in six road names including the 1979-1983 scheme of Western Pacific. Other roads will be Alaska Railroad, Chessie/C&O, Canadian National (1992-1995 scheme), CSX, and Southern Pacific. The HO scale model features a correct scale width hood.



In February, six new decorating schemes will be available on Athearn's HO

scale Bethgon Coalporter. Road names will be BNSF (powder blue swoosh scheme), CCTX-Coletto Creek Power (light blue with yellow end), CR-Conrail, FURX-First Union Rail, OGEX-Oklahoma Gas & Electric, and TGNX-Texas Genco II/NRC. Features include 11 different road numbers, removable coal loads, wire grab

irons, and 100-ton roller bearing trucks. Single cars will have an MSRP of \$39.98 with 5-packs listing at \$199.98.



Also scheduled for release next February is a new production run

of Pullman Standard 4740 cu. ft. triple-bay covered hoppers. The HO scale Ready-to-Roll model represents a prototype from the 1970s. The MSRP will be \$29.98. In addition to the D&RGW car shown here, road names will be PTLX-Far-Mar-Co, TLCX-Bunge Corporation, TLDX-Peavey, Gulf Mobile & Ohio, and Illinois Central.



Late this year, **Atlas** ([atlasrr.com](http://atlasrr.com)) will release a group of uniquely decorated 40' wood refrigera-

tor cars assigned to beer service. In addition to the NWX-North Western Refrigerator Line Company Fox Head Beer car shown here, NWX cars will include Alt-Brau Beer and Stork Club Beer. Cars with FGEX reporting marks will be decorated for Altoona 36 Lager Beer, Fink's Purple Ribbon Beer, and Old Reading Pilsner Beer. Features on the HO scale ready-to-run models include separate door bars, individual grab irons, and uncoupling levers. They will have an MSRP of \$33.95 each. Undecorated models will list at \$27.95.

Atlas has scheduled another production run of its Master Series GP40-2(W) for release during the first quarter of 2015.



contents



index



The HO scale model, which Atlas completely retooled in 2010, is based on a

group of prototypes built for CN in 1976. The release will include a GO Transit model in three new road numbers. In addition to the CN (CNNA scheme) shown here, new road names will be CN (zebra scheme); Aberdeen, Carolina & Western; Central Michigan; Huron & Western; and Pan Am Railways. DC models will have an MSRP of \$159.95. Models with DCC and sound will list at \$269.95.



Atlas has scheduled a release of its HO scale AEM-7/ALP-44 electric locomotive for early next year. Building the prototypes, which were designed to

replace the famous GG1s, was an international project. The principal design company, ASEA of Sweden, supplied the electrical components and contracted with EMD to provide the mechanical equipment and final assembly. A locomotive manufacturer in Austria prefabricated the bodies, except for the first two which were built in the USA by Budd. The AEM-7 and ALP-44 are nearly identical with the principal difference being the grid along the top of the ALP-44 car body. In addition to the NJ Transit version shown here, road names will include Amtrak (as-delivered scheme), Amtrak (Acela scheme), Great

Northern, Lackawanna, Milwaukee Road, Reading, and Pennsylvania Railroad. Visit the above website for pricing and DC/DCC options.



Atlas plans to deliver HO scale versions of a 1993 Ford Explorer during the first quarter of 2015.

Decorating

schemes will be Amtrak, Canadian National, Canadian Pacific, Conrail, Kansas City Southern, NJ Transit, and Norfolk Southern. The ready-to-use models will have an MSRP of \$21.95 each. Non-lettered Explorers will be available painted orange, white, or yellow at an MSRP of \$19.95 each.

---



**Bachmann Trains ([bachmanntrains.com](http://bachmanntrains.com))** introduced several new products at the National Train Show including a computer-generated rendering of a USRA light Mikado. The HO scale steam locomotive is expected to be ready for delivery late this year. Road names will be Union Pacific, Baltimore & Ohio, Pennsylvania Railroad, New York Central, and Maine Central. The model will be equipped with SoundTraxx Sound. The MSRP will be \$379.00.



contents



index

A non-sound version of the Mikado with an MSRP of \$299.00 will be available decorated for Pere Marquette\*, Southern Railway\*, Rock Island, St. Louis-San Francisco, and Western Pacific. The locomotives will come with a USRA medium tender except those with an asterisk\* which will have USRA long tenders.



Bachmann showed a pre-production sample of a 40' double-sheathed wood refrigerator car.

The HO scale model will be available later this year decorated for Merchants Despatch, URT-Union/Soo Line, Pacific Fruit Express, Pure Carbonic Company, and ART-American Refrigerator Transit as shown here with Missouri Pacific and Wabash heralds. The ready-to-run model will have an MSRP of \$34.00.



Another production run of Bachmann's 50-ton two-truck class B Climax has been scheduled for late this year.

The popular geared steam locomotive will have an LED headlight, all-wheel electrical pickup, and a DCC decoder for speed, direction, and lighting. Road names will be Moore-Keppel & Company, W.M. Ritter, Climax demo, and black but unlettered. The MSRP will be \$399.00. A 16-bit Plug-and Play SoundTraxx Tsunami sound module will be available at an MSRP of \$125.00.

Bachmann will rerun its classic American 4-4-0 steam locomotive for delivery late in 2014. Road names will include Atchison,



Topeka & Santa Fe; Central Pacific; Union Pacific; and Baltimore & Ohio. The ready-to-run

locomotive will come with a SoundTraxx sound value package for exhaust chuff, short and long whistles, bell, air pump, and steam release. The MSRP will be \$299.00. A non-sound version with an MSRP of \$229.00 will be offered for Central Pacific, Union Pacific, Western & Atlantic Railroad, and Pennsylvania Railroad. It will be DCC-ready with an 8-pin plug.



An impressive 2-8-4 Berkshire steam locomotive is coming from Bachmann

later this year. The HO scale ready-to-run model will feature a heavy diecast chassis, injection-molded plastic superstructure, and SoundTraxx sound value package for exhaust chuff, short and long whistles, bell, air pump, steam release, and blower. The MSRP will be \$329.00. Road names include Chesapeake & Ohio, Nickel Plate Road (railfan version), and Pere Marquette.



The newest HO scale heavy-weight passenger car from Bachmann is an

80' Pullman 10-2-1 sleeper. Decorating schemes are Atchison, Topeka & Santa Fe; Baltimore & Ohio; New York Central; Union Pacific; and Pennsylvania Railroad as shown here. The MSRP is \$99.00.



contents



index



Later this year, Bachmann plans to release its HO scale EMD GP40 decorated for Union Pacific, Santa Fe, Alaska Railroad, Soo

Line, and Norfolk Southern. The ready-to-run model will have Bachmann's Sound Value SoundTraxx diesel 16-bit package with prototypical prime mover, three air horns, and bell. MSRP \$209.00.

---



**Bowser** ([bowser-trains.com](http://bowser-trains.com)) has several HO scale kits with

an MSRP of just \$14.95. The Pennsylvania class Gs gondola shown here is based on an 11-panel steel car built in the early 1900s with fixed ends. The black and white keystone herald on the model was first applied to the decades old cars in 1954 when more than 1,000 of the original 30,000 Gs gondolas were still on PRR's roster.



Bowser's latest flat car kit is a PRR class F-30 car built circa 1950.



In addition to the Clinchfield version shown here, Bowser's 45' 100-ton triple-bay hopper is

also available decorated for Reading. All of the Bowser car kits shown here have molded-on details. They come with appropriate trucks and knuckle couplers.

---





**Broadway Limited Imports** ([broadway-limited.com](http://broadway-limited.com)) is scheduled to release a

group of EMD SW1500 diesel switchers this month. The HO scale Paragon2 series models will be available decorated for Union Pacific, Southern Pacific (Kodachrome), SP (bloody nose), Western Pacific, Cotton Belt, Southern Railway, Norfolk Southern, Reading, SCL/L&N, and CSX. Another production run of the SW1500 with different road names is expected in November. Details are available at the above website.

---



**B.T.S.** ([btsrr.com](http://btsrr.com)) is selling an HO kits of the Cabin Creek Coal Tipple. This is a major complex that, because of its laser-cut construction, is relatively easy to build. The kit consists of laser-cut bass-

wood, plywood, and cardstock, plus a large supply of brass, plastic, and white metal detail castings. The peel & stick window sash and doors can be installed open or closed. The tipple is served by three tracks. The overall footprint is about 180' x 95'. The HO scale kit is priced at \$299.95. Visit the above website for additional information.

---

**Centralia Car Shops** is selling a large selection of HO scale ready-to-run cabooses. They include Illinois Central side-door cabooses



contents



index



in five different numbers; and Union Pacific's distinctive class CA-3 caboose in 14 different decorating schemes and slogans.



Santa Fe rebuilt class CE-1 way cars are available in seven paint schemes plus several versions of class CE-2 and CE-7 way cars along with eight different versions of early ATSF way cars.



InterMountain Railway is responsible for marketing products manufactured by Centralia Car Shops. For additional information, including pricing, contact your dealer or visit [intermountain-railway.com/distrib/ccs/ccsho.html](http://intermountain-railway.com/distrib/ccs/ccsho.html).



Here is a preview of a 1955 Ford coming soon from **Classic Model Works** ([classicmodelworks.com](http://classicmodelworks.com)). The Mini Model will be available decorated as a Fairlane town sedan,

Customline sedan, and Mainline sedan all in authentic 1955 Ford paint and trim. A tentative release date has been set for mid-September.

---



**Concept Models** ([con-sys.com](http://con-sys.com)) has released kits for two HO scale depressed-center flat cars. Shown above is a KWUX 10 16-axle heavy-duty depressed-center flat car. The prototype is 145' long and has a load limit of 875,000 lbs. The load platform is 38' long. The kit is priced at \$89.99.



Equally impressive is this 142' Kasgro KRL depressed-center flat with a 42' loading platform. It has a load limit of 1.26 million pounds. The eight four-wheel trucks on the prototype have 38" wheels. The kit is priced at \$49.99. The transformer load is sold separately. Concept Models kits consist of resin castings and assembly hardware. Hand grabs, ladders, related metal details, trucks, and couplers are not provided. Assembly instructions are photo illustrated.

---

**Downtown Deco** ([downtowndeco.com](http://downtowndeco.com)) is scheduled to release a new HO scale kit late this month called "Gone Bust Block". The kit includes painting and weathering instructions



contents



index



for finishing the group of buildings which are cast in Hydrocal. Signs shown in the illustration are included. The finished model has a footprint of 12 x 6 inches including the sidewalks. The model will be available direct at \$69.95.

---

**ExactRail** ([exactrail.com](http://exactrail.com)) previewed two different but similar HO scale flat cars at NTS. Like their General Steel Car prototypes, the models look similar at first glance, but the cast underframes have different truck centers.



The Northern Pacific flat car shown above is 53 feet 6 inches long with 42-foot truck centers. In addition to the 1967 as-delivered NP scheme, the HO scale ready-to-run model will be available for Union Pacific in both the 1970 livery and UP's MOW scheme.



This UP car is also 53 feet 6 inches long, but the truck centers are at 43 feet 3 inches. It will be available decorated for Santa Fe 1954 as-delivered MOW scheme, Northern Pacific 1965 scheme, Union Pacific 1962 scheme, and Union Pacific MOW scheme. Both cars feature complex plastic and metal cast underframes and laser-etched deck boards. Pricing and delivery information is pending.

---



**Fox Valley Models' ([foxvalleymodels.com](http://foxvalleymodels.com))** exhibit booth at NTS showed several new items including pre-production samples of EMD GP60M diesel locomotives. Scheduled for release in October, the HO scale ready-

to-run model will be decorated for Santa Fe (warbonnet), Norfolk Southern, and NS Operation Lifesaver scheme. A non-sound DCC-ready version will list at \$199.95. A DCC model with ESU LokSound, \$299.95.

---



**Funaro and Camerlengo ([fandckits.com](http://fandckits.com))** is selling kits for HO scale B&M (Boston

& Maine) and WAG (Wellsville, Addison & Galetton) class XM-1 boxcars. The cast resin kits come with decals and body components and a one-piece body. Trucks and couplers are not included. Visit the above website for details on various door and roof options available.

---



contents



index



**Imperial Hobby Productions** ([ihphobby.tripod.com](http://ihphobby.tripod.com)) has made another production run of a one-piece resin body

casting for a Kansas City PCC Trolley. In addition to Kansas City, the shell is correct for PCC operations in Toronto, Philadelphia, and Tampico, Mexico, all of which acquired the cars after Kansas City Public Service ceased operations. The KCPS body shell is available direct from IHP at \$34.95. It is designed to fit Bowser's #125141 PCC mechanism.

---



**InterMountain Railway** ([intermountain-railway.com](http://intermountain-railway.com)) has released another run of

its ACF type 27 riveted 8,000 gallon tank cars. The HO scale ready-to-run models are available with black tanks decorated for Union Tank Car, Chickasaw Refining, Conoco, Koppers, and Mobilgas. Diamond Chemicals, Baker's Chocolate, and Domino Sugar all have white tanks. Shell, Texaco, and Gibson Wine have silver tanks. Additional road names include Celanese Chemicals (green). Champion Oils/Sterling Fuel (jade), Cook Paints (red), and Union Starch & Refining (red).

InterMountain has scheduled a September release date for the next production run of 50' PS-1 boxcars with single doors. Road names for the HO scale ready-to-run model will include Bangor

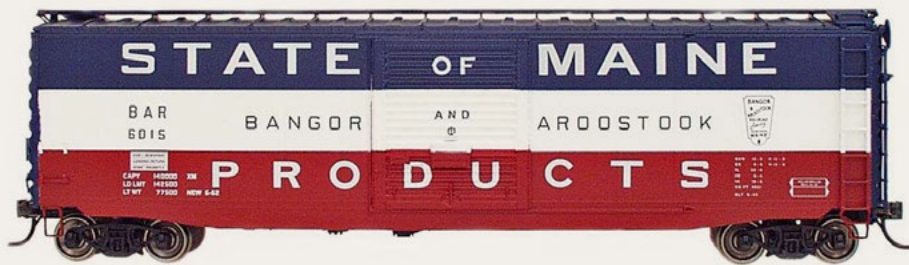

& Aroostook (State of Maine scheme), Santa Fe (class Bx74/75 with billboard lettering), Delaware & Hudson (blue and white with I Love NY Slogan),

Green Bay & Western, Maine Central, and Western Maryland.

Previously announced cars decorated for Seaboard Coast Line (Family Systems) and Missouri Pacific have been cancelled due to lack of reservations.



A new production run of HO scale cylindrical covered hoppers with round

hatches and quad hoppers are expected to be released in September or October. Road names on the ready-to-run models will be Cominco Fertilizers, Canadian National (wet noodle scheme), CN (rainbow scheme), CSX (tan scheme), Anahuac del Golfo, CNIS/North American, and CPLX (CP Rail paintouts).



contents



index



Kadee ([kadee.com](http://kadee.com)) will be releasing an HO scale ready-to-run model of a 50 foot PS-1 box car

decorated for Western Railway of Alabama in October. The model has 9 foot doors, a cushion underframe, and extended couplers. It will have an MSRP of \$36.95. Also coming from Kadee in October is a C&O 40' PS-1 boxcar as manufactured in 1951. Check the above website for pricing information.



Moloco Trains ([molocotrains.com](http://molocotrains.com)) has entered into the ready-to-run arena with the release of this HO scale Erie

Lackawanna 50' General American RBL boxcar. Notable features include a 10'6" offset side door, a newly-tooled overhanging Stanray roof, Stanray R3-4 welded ends, and Moloco's own cushioned draft gear coupler boxes and rubber air hoses. Pricing and additional details are available at the above website.

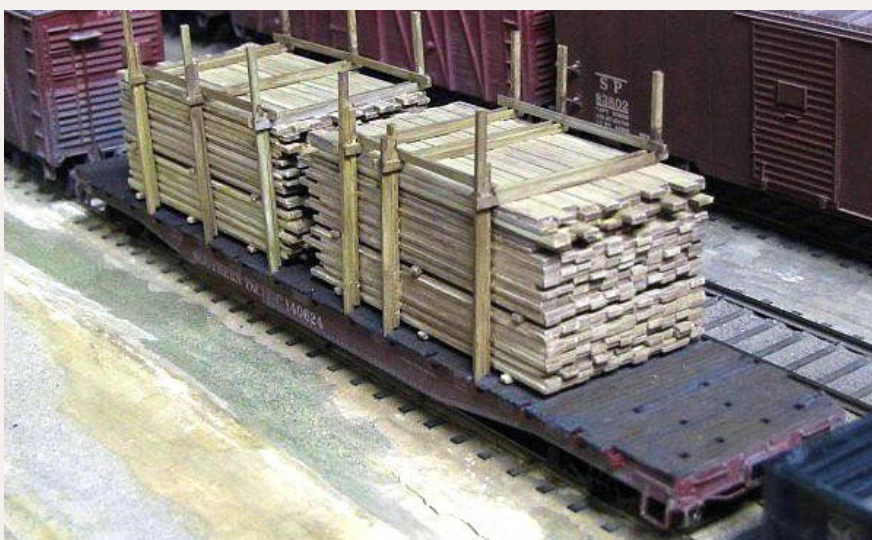

Owl Mountain Models ([owlmt-models.com/lumber/3001.html](http://owlmt-models.com/lumber/3001.html)) has created a modular injection molded lumber load kit for wide-decked HO



scale flat cars. The load consists of 32 “panels” of lumber which can be stacked together to form units and stacks of lumber in a variety of different arrangements. All parts are cast in a light cream-tan color which is a good starting point for weathering and adding wood grain effects. Although specifically designed to fit the class F-70 series flat cars (ex-Red Caboose) sold by the Southern Pacific Historical Society, the load will fit several other flat cars including Walthers/Proto2000’s 53 footer, Bowser’s class F30A, Tichy’s 53 foot GSC, and Athearn Blue-Box 40 foot and 50 foot flat cars. The lumber load is available through the above website.

---

**Rapido Trains Inc.** ([rapidotrains.com](http://rapidotrains.com)) has announced plans to produce an HO scale EMD FL9 locomotive. Built between 1956 and 1960, the FL9 was a dual-power locomotive able to operate as a traditional diesel-electric as well as on direct electric power. This allowed it to handle New Haven Railroad’s passenger trains in and out of New York City’s Grand Central Terminal without the need for an engine change. This is the first time a plastic version of this unique locomotive has been produced. Rapido is cutting new tooling for the models that will include authentic details for both the first and second delivery groups of locomotives including third-rail shoes and pantographs where appropriate.

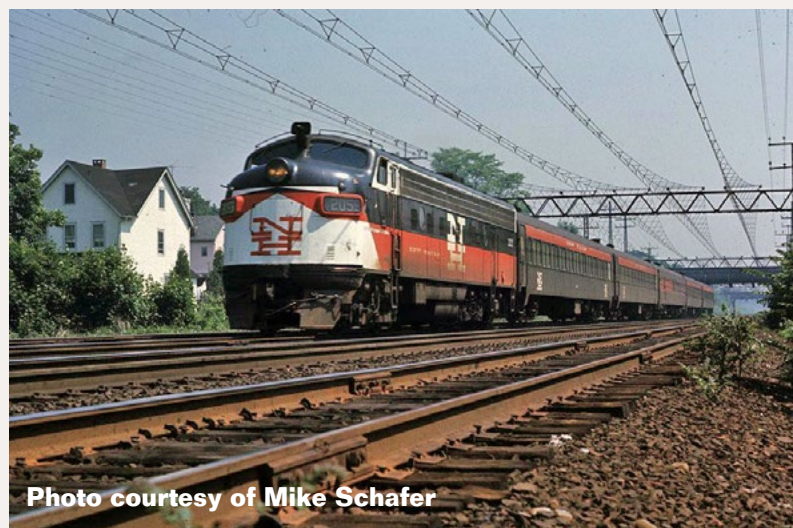

The HO scale models will be available with factory-installed ESU LokSound DCC/sound decoders or as DC models (DCC-ready). The MSRP will be \$249.95



contents



index

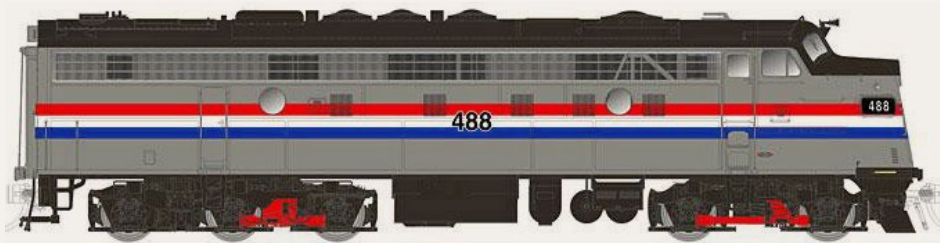

for standard DC and \$349.95 for DC-DCC dual mode with Sound. See an

authorized dealer or visit the above website to reserve.

---

**Hornby America** ([hornbyamerica.com](http://hornbyamerica.com)), the North American distributor for several European product Lines, including Rivarossi, showed several new items in their National Train Show display booth. Drawing considerable attention was this HO scale Virginian Railroad class AG 2-6-6-6 steam locomotive. The model features a heavy diecast metal chassis with an injection molded plastic superstructure. Of note are the RP25 contour wheels. A standard DC version of the HO scale ready-to-run locomotive will have an MSRP of \$479.99. A DCC version with ESU LokSound V4.0 dual-mode decoder will list at \$599.99.



Hornby also showed pre-production samples of a Rivarossi U25C diesel at NTS. While Jeff Shultz of MRH was taking this close-up photo of the ACL sample, a company representative pointed out that while the stanchions are correctly sized, the profile of the handrails will be reduced by about 30 percent in the production version. Final pricing and release dates are pending.



---

**Roundhouse Division of Athearn ([athearn.com](http://athearn.com))** plans to release a 40 foot wood reefer with steel underframe in



February. In addition to the Canadian National (maple leaf herald) ver-

sion shown here, three numbers each will be available for Pacific Fruit Express (Southern Pacific herald), PFE (Western Pacific herald), National Refrigerator Company (A&P scheme), and NRC (Yakima Valley Apples scheme). The HO scale ready-to-run model will have an MSRP of \$19.98.

---

**Tangent Scale Models ([tangentscalemodels.com](http://tangentscalemodels.com))** showed samples of its new HO Scale General American Dry-Flo covered hopper at the National Train Show. The model is based on a 3500 cu. ft. car General American Transportation Corporation produced beginning in 1959. This is the first time this prototype has been produced in HO scale.

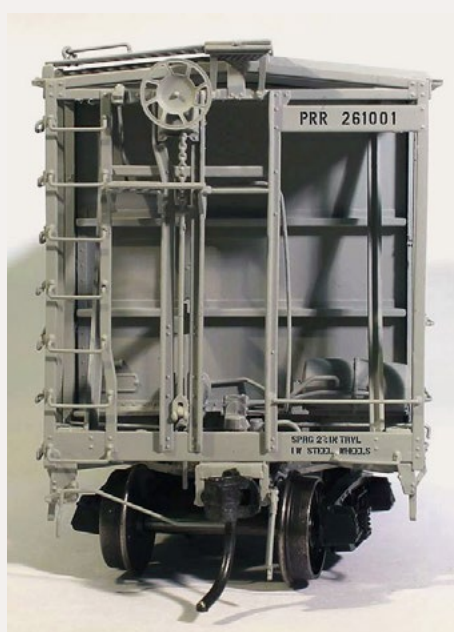

Special features include nicely detailed gravity-pneumatic outlet gates, Kadee couplers and, depending on the road name, either ASF 70-ton Ride Control plain bearing trucks or Barber S-2-A 70-ton roller bearing trucks. Road names include Burlington Northern (Cascade green), Conrail, Illinois Central, Northern Pacific, Pennsylvania Railroad, Union Pacific (Albina silver), GACX-DOW Freeport TX, and GACX-Diamond Sugar – Montreal. An



contents



index



unpainted kit is available as well as an assembled but undecorated model.



Tangent has released the second production run of its highly-regarded General American triple-compartment

6,000 gallon tank car. Road names in this run include schemes for prototypes operating between 1929 and the 1980s. They are STCX - Standard Tank Car Company (black, 1930 to early '40s), MPCX - Magnolia Petroleum Company (1935, black and silver), GATX - General American Transportation (black, new road numbers, 1941+), GATX - General American Transportation (black, 1958+), GATX - General American Transportation (black, 1968-1974), HHCX - Champlin Refining Company (white, Enid, OK, 1952+), GATX - Celanese Chemicals (green, with red and white graphics, 1952+), D&H – Delaware & Hudson Company Service (ex-GATX black scheme, 1972), and undecorated as shown here.



Also available now from Tangent is another run of Pullman-Standard PS-2CD 4750

covered hoppers, the largest production covered hopper design

in history. The HO scale models and decorating schemes represent prototypes in service from the 1970s to the present. The four new road names are PTLX – Landmark Uniopolis OH (red, white, and black), PTLX – Landmark Washington C.H. OH (red, white, and black), PTLX - Cargill Salt (green), and PTLX - Michigan Elevator Exchange (yellow with black underframe and ends). Visit Tangent’s website for complete description, prototype photos, reference material and pricing information. Note that Tangent allows mixing for multiple car discounts on quantity purchases.



During the Cleveland National Train Show, **Walthers** ([walthers.com](http://walthers.com)) showed pre-production samples of their forthcoming Baltimore & Ohio Capitol Limited train set. Led by appropriately decorated E9A and E8Bm diesel units, the 10-car consist includes several new cars and the only dome cars to operate in the east.

Delivery of the individual cars, which are all 85 feet long, will be one per month beginning with a Budd-built 24-8 Slumbercoach sleeper in November followed by a Pullman-Standard 10-6 sleeper with fluted sides in December. The new year will begin with the release of a Budd 16-4 sleeper, followed by a P-S kitchen/dormitory car in February, a P-S 56-seat dining car in March, and a P-S 56-seat coach in April. May will see the release



contents



index

of a P-S baggage-dorm-coffee shop-lounge, followed in June by a P-S Strata-Dome coach, and a Budd Strata-Dome 5-1-3 sleeper in July. The consist will be completed in August with the release of a P-S 5-bedroom-buffet-lounge-observation car.

Matching Proto diesels based on B&O class DP-6 (E9A) and rebuilt DP7-X (E8Bm) units will have special details such as a raised B&O Capitol Dome shield, brass Nathan M5 air horn, single headlight with flush lens and gasket detail, flush number boards, stainless steel side grilles, fuel tank skirts, and an ATS shoe on engineer's side of the front truck. Models will be available for standard DC operation and with SoundTraxx Tsunami Sound for DCC or DC operation. Check the above website for pricing and additional details on Walthers B&O Capitol Limited.

A limited-run 10-car Deluxe Edition of the Capitol Limited will feature factory-printed car names and numbers, factory-installed LED interior lighting, and more than 150 Preiser figures. For additional information on the Deluxe Edition collector set visit [walthers.com](http://walthers.com).



Also on display in the Walthers NTS booth were several pre-produc-

tion samples of new lightweight passenger cars. The full-length cars are in Walthers Mainline series (mid-level) and will have a reasonable amount of detail along with truck-mounted couplers for operation on 18" radius curves. A conversion set will be available to convert to body-mount couplers.

Also on display was an early test shot of a Walthers Mainline series 40 foot AAR 1944 boxcar. The finished product is scheduled for release late next January. Features of the 10 foot 6



inch interior boxcar include tab side sills, 4-4 Improved Dreadnaught ends, 6 foot Youngstown doors, and

a Murphy panel roof. Road names on the initial run will be Chicago, Burlington & Quincy; Santa Fe; Canadian National; Canadian Pacific; Northern Pacific, New York Central, and undecorated. The ready-to-run model will have an MSRP of \$24.98.



Walthers is selling an HO scale Trainline series flat car decorated for Canadian

Pacific, D&RGW, TTX, and C&O Chessie System. This is an entry-level flat car of generic design with molded-on details, metal wheel sets, and knuckle couplers. The ready-to-run model has an MSRP of \$17.98.



Walthers has scheduled a November release date for an HO scale kit version of the Pella depot. The medium sized brick structure is based on a Rock Island prototype now serving as a museum in Pella, IA. The assembled

depot has a footprint of 12 x 5 by 3½ inches. The model will have an MSRP of \$39.98.



contents



index

# N SCALE PRODUCT NEWS



Atlas ([atlasrr.com](http://atlasrr.com)) is selling an N scale EMD GP35 diesel decorated for Western Maryland,

Canadian Pacific, Railink Canada, Reading, Conrail, Great Northern, Union Pacific and Atlantic Coast Line. The Master Line model is available for standard DC operation at an MSRP of \$119.95. Locomotives equipped with a DCC decoder list at \$154.95.



This N scale 40' plug-door boxcar will be available from Atlas with new decorating schemes late this year. Road names will

include Transport Leasing Co., Merchants Despatch, Mountain Pine Lumber Co., North American Car Co., Pennsylvania Railroad, and Penn Central. The MSRP on this Trainman series model will be \$17.95. An undecorated version will be list at \$13.95.



This Trainman series aluminum coal gondola from Atlas will be available during the third quarter of this year decorated

for Penn Central, Pennsylvania Railroad, BNSF, CIT Group, and Somerset Railroad. The N scale model is based on an AAR type J311 gondola. The prototype has rotary couplers. The MSRP will be \$24.95. An undecorated version will list at \$19.95.



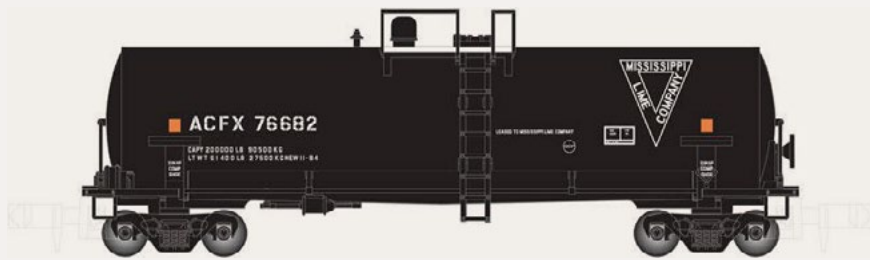

Atlas plans to release another production run of 14,000 gallon kaolin tank car with new

numbers and new road names during the first quarter of 2015. The N scale ready-to-run version of the 1970s-era prototype will be decorated for Mississippi Lime and United Clays. New road numbers will be available for previously released roads including ACFX, Engelhard, Georgia Kaolin, J.M. Huber, and Omya. The models will have an MSRP of \$27.95. Undecorated models will list at \$22.95.



Additional N scale items scheduled for release during the first quarter of next year include a Trainman series twin-bay Centerflow covered hopper car.

In addition to the D&RGW car shown here, other road names will be Canadian National (DT&S), Burlington Northern, Western Maryland, Blue Circle Cement, and Erie Lackawanna. The MSRP will be \$16.95. Undecorated versions will be available at a list price of \$12.95.



Atlas plans to deliver N scale versions of a 1993 Ford Explorer during the first quarter of 2015. Decorating schemes



contents



index

will be Canadian Pacific, Canadian National, Amtrak, Conrail, Kansas City Southern, NJ Transit, and Norfolk Southern. The ready-to-use models will be offered in two-packs with an MSRP of \$29.95. Two-packs of undecorated Explorers will be available painted orange, white, or yellow at an MSRP of \$26.95.

N scale motive power coming from Atlas in the second quarter of 2015 includes several versions of EMD SD50/SD60/SD60M diesels. Although nearly identical externally, spotting features to help identify the three locomotives include four latched



doors in six door panels (SD50), six latched doors in eight door panels (SD60), and a two-piece windshield (SD60M). Road names for the Atlas SD50 will be Utah Railway, CSX (blue and yellow YN3B scheme), and Norfolk & Western.



The SD60 will be decorated for EMD, Canadian National, and GATX Locomotive Group.

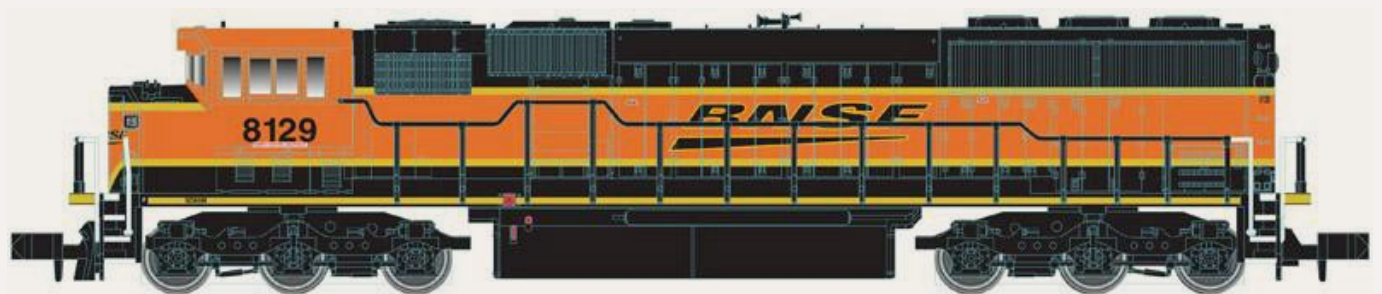

Road names for Atlas's SD60M will be BNSF, Canadian Pacific, and CSX (blue and yellow YN3 scheme). Check the above website for pricing of DC and DCC/sound versions as well as pricing and availability of undecorated models.

---



**Athearn** ([athearn.com](http://athearn.com)) will release six new decorating schemes for its N scale Bethgon Coalporter in February. Road names will be OGEX-Oklahoma Gas & Electric, BNSF (powder blue swoosh scheme), CCTX-Coleto Creek Power (light blue with yellow end), CR-Conrail, FURX-First Union Rail, and TGNX-Texas Genco II/NRC. Features include 11 different road numbers, removable coal loads, wire grab irons, and 100-ton roller bearing trucks. Single cars will have an MSRP of \$19.98 with five-packs listing at \$99.98.

---



**Bachmann** ([bachmanntrains.com](http://bachmanntrains.com))

introduced several new N scale items at NTS includ-

ing a sound- equipped EMD SD45 diesel locomotive. In addition to the NP version shown here, road names will be Erie Lackawanna, Pennsylvania Railroad, D&RGW, and Santa Fe. The ready-to-run model will be available later this year at an MSRP of \$249.00.



contents



index



An N scale 2-8-4 Berkshire steam locomotive is also scheduled to be released later

this year. The ready-to-run model will be equipped with DCC sound at an MSRP of \$329.00. Road names will include Pere Marquette, Chesapeake & Ohio Kanawha in two road numbers, and Nickel Plate Road in contemporary rail fan scheme as shown here in an HO scale version of the model.

Additional N scale items coming from Bachmann this year include a 50 foot plug-door boxcar decorated for New York, New Haven & Hartford; Santa Fe, CP Rail, New York Central, and Pennsylvania Railroad. The tooling has been upgraded on this ready-to-run model that will have an MSRP of \$32.00.



**BLMA Models** ([blmamodels.com](http://blmamodels.com)) announced a new N scale flat car

at NTS. The model is closely based on a 60 foot steel flat car with a cast frame as produced by General Steel Casting in the 1950s. Special features of the ready-to-run model include train line hoses, and 70-ton Ride Control trucks. In addition to the Wabash version shown here, the newly-tooled model will be available decorated for ATSF (1956 scheme), Burlington Northern, Illinois Central, Pennsylvania (class F-47), and SSW- Cotton Belt. Four numbers will be available for each road name at an MSRP of \$22.95 each. Delivery is scheduled for early next year.



## Fox Valley Models

showed pre-production samples of their new Baltimore & Ohio class I-12 wagon-top cabooses at NTS. Four versions of the N scale

model will be available later this year including B&O (1940s scheme), B&O (late 1950s scheme), B&O (blue, pool service scheme), and Chessie System (yellow, B&O from 1973 to early 1980s). The ready-to-run models will have an MSRP of \$34.95. InterMountain Railway is responsible for marketing Fox Valley products. For additional information visit [intermountain-railway.com](http://intermountain-railway.com).

---

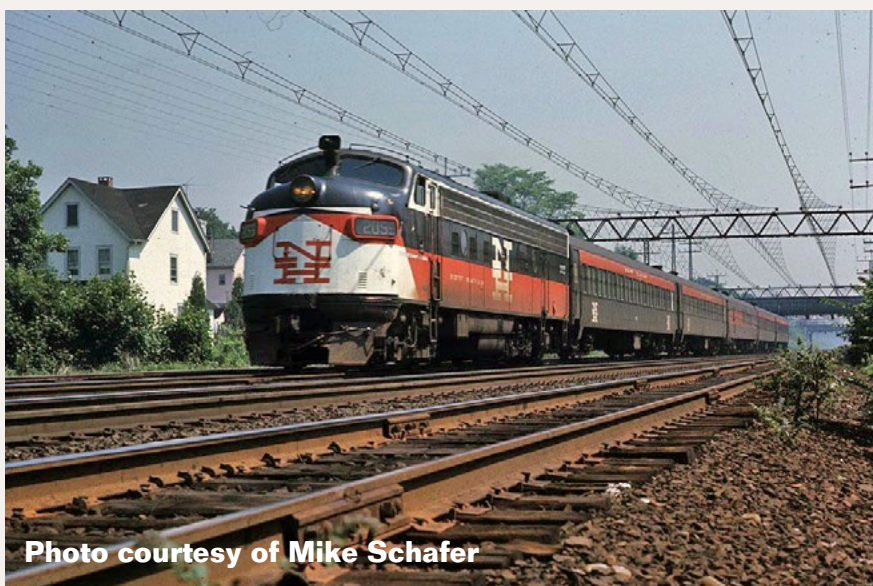

## Rapido Trains Inc.

([rapidotrains.com](http://rapidotrains.com))

has announced plans to produce an N scale EMD FL9 locomotive. Built between 1956 and 1960, the FL9 was a dual-power locomotive able to

operate as a traditional diesel-electric as well as on direct electric power. This allowed it to handle New Haven Railroad's passenger trains in and out of New York City's Grand Central Terminal without the need for an engine change. This is the first time a plastic version of this unique locomotive has been produced. Rapido is cutting new tooling for the models that



contents



index

will include authentic details for both the first and second delivery groups of locomotives including third-rail shoes and pantographs where appropriate.



The N scale models will be available for standard DC operation at an MSRP of \$169.95 or with

ESU LokSound DCC sound decoders at an MSRP of \$279.95. Production quantities will be based on reservations with delivery planned for early fall of 2015. See an authorized dealer or visit the above website for reservation information.

---



**Walthers ([walthers.com](http://walthers.com))** showed preliminary samples of an N scale EMD GP38-2 with an 88”

low nose at NTS. The ready-to-run diesel locomotive will be available late this year with an MSRP of \$99.98. Road names will be BNSF, Canadian National, Conrail, CSX, Union Pacific, and Soo Line.

---

# NEW DECALS, SIGNS AND FINISHING PRODUCTS

Archer Fine Transfers ([archertransfers.com](http://archertransfers.com)) has released several new sheets of Resin Rivet surface detail including

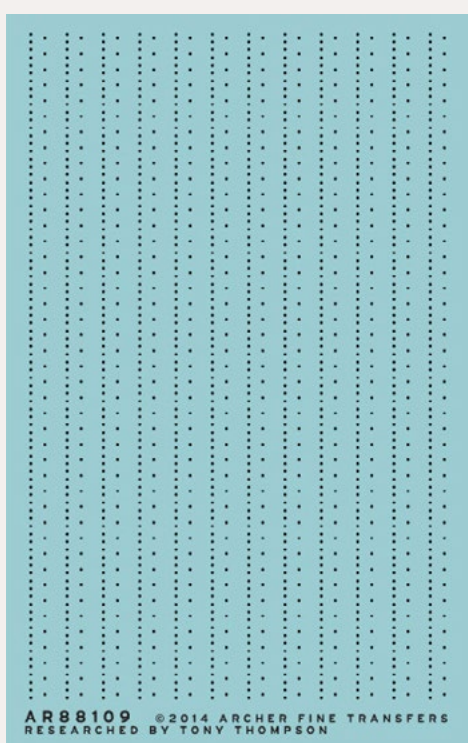
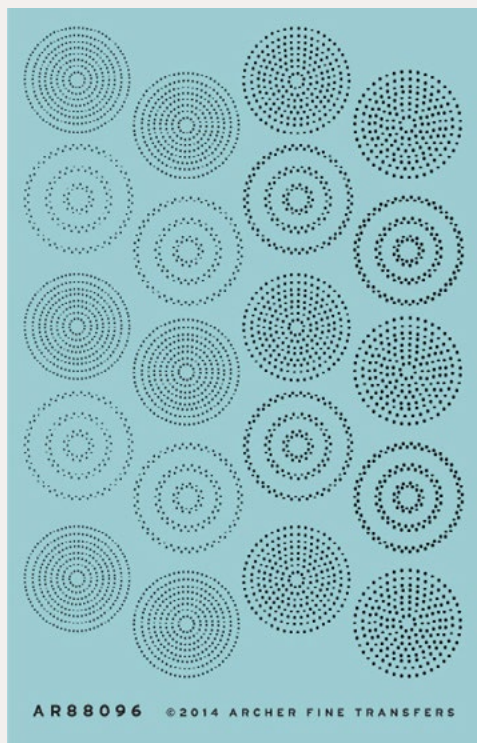

various sizes of rivets in circular patterns. Also new is double row of staggered rivets especially suited for flange applications, as suggested to

Archer by Tony Thompson. Large rivet heads (1.25" diameter) are now available in both single and double row patterns

---

**George's Trains** ([georgestrains.com](http://georgestrains.com)) of Ontario, Canada, has introduced a new acrylic paint that is said to be airbrush-ready. It dries to a gloss finish ready for decaling. The 20 introductory colors are based on specific Canadian prototypes. They are: CNR - green, imitation gold, red, red/orange, grey, and lettering grey; CN/VIA – blue and yellow. CPR – Tuscan, diesel grey, diesel yellow, steam grey, and mineral brown; CP – bright red, Action red, Action yellow, and Action green. TH&B – cream and maroon. The paint is priced at \$8.98 for a one-ounce bottle.

---

New HO scale decals released by **Mask Island** ([maskisland-decals.com](http://maskisland-decals.com)) include Milwaukee Road 50' double-door boxcars,



contents



index

B&O N-17 and N-26 twin-bay hoppers, and Milwaukee Road 50' double-door outside-braced automobile cars.

---

**New England Rail Service** is selling HO scale decals for New Haven passenger equipment. Each set contains eight pairs of the New Haven road name in the 5.5 style in two different lengths as used on various New Haven non-Pullman operated passenger cars. A futura-styled number jungle is included. There are four pairs of each length of the New Haven lettering. Lettering for RPO and baggage cars used by the Railway Express Agency are included. All lettering and numbers are in New Haven's silver-gray color. The retail price is \$9.95 per set plus \$1.00 shipping per order for up to five sets. Order direct from New England Rail Service, P.O. Box 1059, Leesburg, VA 20177.

---

New HO scale decals from **Dan Kohlberg** ([home.mindspring.com/~paducah/](http://home.mindspring.com/~paducah/)) include four lettering sets for General American Dry Flo covered hoppers. They are ICG-70 Illinois Central (gray, as delivered, 1960), ICG-71 Illinois Central Gulf (gray repaint, 1974+), GA-17 GACX Lease cars (plain gray, 1958+), and GA-18 Quaker Oats (gray, 1962+). Visit the above website for specific prototype information and pricing.

---

**San Juan Decals** ([sanjuandecals.com](http://sanjuandecals.com)) is selling lettering sets for D&RGW series 6300 flat cars. The decal set scaled for On3 (Item SJD-372) is priced at \$8.95. The decal set for 15mm equipment (Item SJD-374) sells for \$10.95.

---



The Tichy Train Group ([tichytraingroup.com](http://tichytraingroup.com)) is now producing its decals in-house. This should eliminate out-of-stock issues and end some of the prolonged back orders experienced in the past. HO scale decals currently available include MOW and Wreck Train House car lettering sets in both black and white in Roman and Gothic fonts. White lettering for Tichy flat cars in Roman and Gothic are also in stock now. Also available are UTLX decal sets for Tichy 4020 and 4025 tank cars.

---



## **DISCLAIMER ..**

The opinions expressed in this column are those of the writer and do not necessarily reflect the opinion of Model Railroad Hobbyist or its sponsors. Every effort is made to provide our readers with accurate and responsible news and information, however, neither Model Railroad Hobbyist or the writer of this column can be held responsible for any inaccuracies or typographical errors that may inadvertently appear in this column.



contents



index

## Selected Events



### August 2014

**ARIZONA, PRESCOTT**, August 16, Annual Beat The Heat Swap Meet, sponsored by Central Arizona Model Railroad Club, at Prescott Activity Center, 824 E. Gurley Street. Info from Steve Bumgardner at 928-775-3184.

**CALIFORNIA, TEHACHAPI**, August 9-10, Summer Model Train Show, sponsored by Tehachapi Loop Railroad Club, at West Park, 491 West D Street. Info at [tehachapilooprailroadclub.org](http://tehachapilooprailroadclub.org).

**FLORIDA, THE VILLAGES**, August 16-17, Summer Model Train Show and Sale at Savannah Regional Recreation Center, 1545 Buena Vista Blvd. Sponsored by The Villages Railroad Historical Society. Info from Alan Goldberg 352-205-4322, or email: [amgold15@hotmail.com](mailto:amgold15@hotmail.com).

**ILLINOIS, COLLINSVILLE (Metro St. Louis, Missouri)**, August 8-9, St. Louis Railroad Prototype Modeler's Meet, at Gateway Convention Center. Featuring clinics by David Lehlbach, Pierre Oliver, Clark Propst, Jared Harper, Ed Hawkins, and Bill Schaumburg. View St. Louis RPM 2012 video produced by Ken Patterson for Model Railroad Hobbyist magazine at [youtube.com/watch?v=oins4ipx68E](http://youtube.com/watch?v=oins4ipx68E).

**MISSOURI, ST. LOUIS**, August 24, Annual Model Train Show at the Museum of Transportation, 3015 Barrett Station Road. Info at [transportmuseumassociation.org](http://transportmuseumassociation.org).

**NEW HAMPSHIRE, CONCORD**, August 17, 29th Annual Train Show, at Everett Arena, sponsored by Concord Model Railroad Club. Info at [trainweb.org/cmrc/index.html](http://trainweb.org/cmrc/index.html).



**PENNSYLVANIA, EVERETT**, August 23-24, N-Scale Weekend Model Train Show, sponsored by Bedford Model Railroaders, at Sportsplex, 125 Willow Grove Drive.

**PENNSYLVANIA, STRASBURG**, August 9, Eastern PA 2-Rail Scale & Hi-Rail Train Show at Strasburg Fire Company, 203 West Franklin Street. Visit the nearby Strasburg Railroad, Pennsylvania State Railroad Museum. Info from Rich Yoder 610-678-2834.

**TENNESSEE, NASHVILLE**, August 23, Summer Train Show sponsored by Music City Chapter of the Dixie Division TCA. Event at Donelson First Baptist Church Gym, 2526 Lebanon Road. Info at [dixiedivisiontca.com](http://dixiedivisiontca.com).

**VIRGINIA, CHANTILLY**, August 7-10, Capitol Limited N Scale East Convention, co-sponsored by Northern Virginia NTRAK and Greenberg Train and Toy Shows, at Dulles Expo Center. Info at [info@bigtrainlayout.org](mailto:info@bigtrainlayout.org).

## September 2014

**CANADA, QUEBEC, MONTREAL**, September 27-28, Montreal Model Train Exposition, at Sun Youth Centre, 4251 Urbain Street. Info at [montrealtrainexposition.com](http://montrealtrainexposition.com).

**ARIZONA, PHOENIX**, September 18-20, National Convention of Timetable Collectors, at Crowne Plaza Phoenix North. Info at [naotc.com](http://naotc.com).

**CALIFORNIA, SAN DIEGO**, September 3-7, 2014 NMRA Pacific Southwest Region Convention, at Marriott Courtyard Hotel, 595 Hotel Circle South. Info at [psrnmra.org](http://psrnmra.org)..

**CANADA, ONTARIO, THUNDER BAY**, September 30-October 3, Canadian Railway Modellers convention with clinics, prototype tours, banquet, and railfanning. At Prince Arthur Waterfront Hotel. Info at [caorm.org/crc2014](http://caorm.org/crc2014).



contents



index

**CALIFORNIA, SANTA ROSA**, September 19-21, 6th Annual Redwood Empire Train Show (in conjunction with Fall Home show), at Sonoma County Fair Grounds, 1350 Bennett Valley Road. Info at [sonomacountyfair.com/events.php](http://sonomacountyfair.com/events.php).

**COLORADO, COLORADO SPRINGS**, September 12-14, TECO Train Expo Colorado, at Freedom Financial Services Expo Center, 3660 North Nevada Avenue. Info at [tecoshow.org](http://tecoshow.org).

**GEORGIA, KENNESAW**, September 19-20, Atlanta Railroad Prototype Modelers Meet, sponsored jointly by the Southern Railway Historical Association, Atlantic Coast Line & Seaboard Airline Railroads Historical Society, Central of Georgia Railway Historical Society, and Nashville Chattanooga & St Louis Preservation Society. At the Southern Museum of Civil War and Locomotive History, 2829 Cherokee Street. Info at [srha.net/](http://srha.net/) or contact Frank Greene at [frgreene290@comcast.net](mailto:frgreene290@comcast.net).

**INDIANA, MIDDLEBURY**, September 12-13, NMRA Michiana Division 2014 Education & Training Conference, at Das Dutchman Essenhaus Conference Center. For info send email to [danbrewer.nmra@yahoo.com](mailto:danbrewer.nmra@yahoo.com).

**KANSAS, OVERLAND PARK** (Metro Kansas City, Missouri), September 3-6, 34th National Narrow Gauge Convention. Info at [kansascity2014.com](http://kansascity2014.com).

**MASSACHUSETTS, PALMER**, September 11-14, NMRA NER Convention. Info at [nediamonds2014.org](http://nediamonds2014.org).

**NEBRASKA, NORTH PLATTE**, September 19-21, North Platte 2014 Rail Fest Model Train Expo, at National Guard Armory, 1700 N. Jeffers St. Info at [nprailfest.com](http://nprailfest.com).



**VERMONT, RUTLAND**, September 27, Rutland Train Show, featuring model trains, railroad history, and vendors, at Holiday Inn, State Route 7. Co-sponsored by the Rutland Railway Association and Rutland Railroad Museum. Info at [therutlandrailwayassociation.org](http://therutlandrailwayassociation.org).

**VIRGINIA, FREDERICKBURG**, September 12-13, Mid-Atlantic Railroad Prototype Modelers Meet, with model displays, clinics, and RPM camaraderie. At Wingate by Wyndham Hotel, 20 Sanford Drive. Info at [marpm.org](http://marpm.org).

## **Future 2014 (by location)**

**CANADA, BRITISH COLUMBIA, BURNABY**, November 8-9, Trains 2014 32nd Annual Model Train Show featuring operating trains, dioramas, kids activities, and vendors. For registrants there are operating sessions (November 7), clinics, model contests, layout tours, a prototype modelers meet, and banquet. At Cameron Center, 9523 Cameron Street. Info at [bctrains.org](http://bctrains.org).

**CANADA, ONTARIO, HAMILTON**, November 1, Hamilton District Layout Tour. Home and club layouts in Burlington, Beamsville, Fenwick, Caledonia, and Hamilton. Guide books will be available in October at local model railway shops. Info from Brandon Bayer at [brandon1@cogeco.ca](mailto:brandon1@cogeco.ca).

**CANADA, QUEBEC, LAVAL**, October 4-5, The North Shore Train Show, at Complexe Multi-Sports, 995 rue Bois-de-Boulogne. Info at [salondutrainrivenord.org](http://salondutrainrivenord.org).

**CONNECTICUT, ORANGE**, October 12, 22 Annual Model Train Show, at High Plains Community Center, 525 Orange Center Road (Route 152). Sponsored by New Haven & Derby Model Railroad Club. Info at [newhaven-derbymodelrailroadclub.org](http://newhaven-derbymodelrailroadclub.org).



contents



index

**FLORIDA, PALM BAY**, December 21, HO Scale Module Display, at Franklin T. Degroot Memorial Library, 6475 Minton Road. Sponsored by Palm Bay Model Railroad Club.

**ILLINOIS, NAPERVILLE**, October 9-11, 21st Annual Naperville RPM Conference, hosted by Joe D'elia at Sheraton Lisle-Chicago Hotel, 3000 Warrenville Road, Lisle. Info at [railroadprototypemodelers.org/naper\\_meet.htm](http://railroadprototypemodelers.org/naper_meet.htm).

**INDIANA, DANVILLE**, November 22, NMRA Central Indiana Division Train Show, at Hendricks County Fair Grounds. Info at [cid.railfan.net](http://cid.railfan.net).

**MICHIGAN, MUSKEGON**, October 26, Fall Model Train Show, sponsored by Muskegon Railroad Historical Society, at Golden Token Hall, 1300 E. Laketon Ave. Info at [mrhs-online.org](http://mrhs-online.org).

**OHIO, WEST CHESTER**, October 11-12, NMRA Mid-Central Region, Cincinnati Division 7, 47th Annual Model Railroad Show. At Lakota West High School, 8940 Union Centre Blvd. Info at [cincy-div7.org](http://cincy-div7.org). Sales table info from Roy Hord at (513) 777-5337 or [rhord@fuse.net](mailto:rhord@fuse.net).

**TEXAS, FOREST HILL**, October 11-12, Texas Western Train Show, featuring model train modular layouts, vendor displays, clinics, nearly 100 sales tables, contests, door prizes, and free parking. At Forest Hill Civic and Convention Center, 6901 Wichita Street. Info at [twtrain-show.com](http://twtrain-show.com).

**WASHINGTON, CHEHALIS**, October 11-12, All Scales Annual Fall Model Railroad Swap Meet and Train Show, sponsored by Lewis County Model Railroad Club. Event at Southwest Washington Fair Grounds, Blue Pavilion Building, 2555 North National Avenue. Info at [lewiscountymuseum.org/model-train-show-swap-meet](http://lewiscountymuseum.org/model-train-show-swap-meet).



## Future 2015 (by location)

**AUSTRALIA, CANBERRA**, March 28-29, 2015, 27th Annual Canberra Model Railway Expo, hosted by Canberra Model Railway Club, at University of Canberra High School, 104 Baldwin Drive. Info at [canberra-model-railway-club.webs.com](http://canberra-model-railway-club.webs.com).

**CALIFORNIA, NEWARK**, May 13-17, 2015, NMRA Pacific Coast Region Convention, at Newark-Fremont Double Tree by Hilton Hotel, 39900 Balentine Drive. Info at [pcrnmra.org/conv2015](http://pcrnmra.org/conv2015).

**FLORIDA, COCOA BEACH**, January 8-10, 2015, Prototype Rails RPM meet hosted by Mike Brock, at Cocoa Beach Hilton Hotel, 1550 North Atlantic Avenue. Info at [prototyperrails.com](http://prototyperrails.com).

**OREGON, PORTLAND**, August 23-30, 2015, NMRA National Convention, at Double Tree by Hilton Hotel Portland. Info at [nmra2015.org](http://nmra2015.org).

**OREGON, PORTLAND**, August 28-30, 2015, National Train Show, at Portland Expo Center. Info at [nmra2015.org/trainshow](http://nmra2015.org/trainshow).

**PENNSYLVANIA, PHILADELPHIA**, May 15-17, 2015, Biennial Meet of the East Penn Traction Club, at Pennsylvania Convention Center. Info at [eastpenn.org/2015\\_meet\\_announcement.htm](http://eastpenn.org/2015_meet_announcement.htm).

**TEXAS, HOUSTON**, September 2-5, 2015, 35th National Narrow Gauge Convention. Info at [nngc-2015.com](http://nngc-2015.com).

**WASHINGTON, BELLEVUE**, April 16-18, 2015, 30th Annual Sn3 Symposium, at Bellevue Sheraton Hotel, 100 112th Ave NE.

## Future 2016 and beyond (by location)

**INDIANA, INDIANAPOLIS**, July 3-10, 2016, NMRA National Convention and National Train Show. Info at [nmra2016.org](http://nmra2016.org).

**MAINE, AUGUSTA**, Sept. 7-10, 2016, 36th National Narrow Gauge Convention. Info at [nngc2016.org](http://nngc2016.org). ■



contents



index

# Clickable advertiser index – 1

[Accu-Lites](#)  
[Amherst Railway Society](#)  
[An Affair With Trains](#)  
[Archer Fine Transfers](#)  
[Athearn](#)  
[Atlas Model Railroad Co.](#)  
[Bachmann](#)  
[Bachrus](#)  
[Backdrop Junction](#)  
[Berrett Hill Trains](#)  
[Blair Line](#)  
[BLMA](#)  
[Bollinger Edgerly Scale Trains](#)  
[Bowser](#)  
[Caboose Hobbies](#)  
[Canyon Creek Scenics](#)  
[Clever Models](#)  
[Coffman Graphics](#)  
[Coastmans Scenic Products](#)  
[Credit Valley Railway](#)  
[DCC by Design](#)  
[Digitrax \(2 page spread\)](#)  
[D's Model Trees](#)  
[ESU LokSound](#)  
[Fast Tracks](#)  
[Fifer Hobby Supply](#)  
[Fox Valley Models](#)  
[GLX Scale Models](#)  
[Great Decals](#)  
[Iowa Scaled Engineering](#)  
[Iwata-Medea](#)  
[Jelsma Graphics](#)  
[Litchfield Station](#)  
[Logic Rail Technologies](#)  
[Microscale](#)  
[Minimalist Model Railroad](#)  
[Motrak Models](#)  
[Mr. Detail Parts](#)  
[MRH Store \(MTV\) \(1\)](#)  
[MRH Store \(MTV\) \(2\)](#)  
[MRH Store \(MTV\) \(3\)](#)  
[M.T.H.](#)  
[Mullet River \(O scale\)](#)  
[Nano-Oil](#)  
[National Narrow Gauge](#)  
[NCE \(2 page spread\)](#)  
[Nick & Nora Designs](#)  
[North American Railcar](#)  
[Rail Design Services](#)  
[RailMaster Hobbies](#)  
[Railroad Explorer](#)  
[Rapido \(2 page spread\)](#)  
[Ring Engineering \(1\)](#)  
[Ring Engineering \(2\)](#)  
[RR-CirKits](#)  
[RSlaserKits, Inc.](#)  
[Rulers-of-the-World](#)  
[Rusty Stumps](#)  
[San Juan Car Co.](#)  
[Streamlined Backshop](#)  
[Scenic Express](#)  
[Scotty Mason Show](#)  
[Signature Press](#)  
[Soundtraxx](#)  
[Southern Digital](#)  
[TAM Valley Depot](#)  
[TCS](#)  
[The North Shore Train Show](#)  
[Tony's Train Exchange](#)  
[TrainMaster Models](#)  
[TrainMasters \(1\)](#)  
[TrainMasters \(2\)](#)  
[TrainMasters \(3\)](#)  
[True Line Trains](#)





# Clickable advertiser index – 2

[True Scene Modeling](#)  
[TSG Multimedia](#)  
[Westerfield Models](#)

[Yankee Dabblers](#)  
[Yarmouth Model Works](#)

## Clickable topic index

[DCC Impulses – HO Sound DCC installation](#)

[Editorial – Assitant Editor’s Thoughts](#)

[Editorial – Reverse running](#)

[First Look – N scale SP&S Alco RS-3](#)

[Getting Real – Layout Building Productivity Part 1](#)

[Layout – The Kayton Shortline](#)

[News – August Newsletter](#)

[News – August Events](#)

[Q and A – MRH Questions, Answers, and Tips](#)

[Rolling Stock – Realistic “Rustbucket Weathering”](#)

[Rolling Stock – Building Your First Resin Car](#)

[Techniques – An Introduction into 3D Modeling](#)

[Trackwork – Realistic Switch Control](#)

[The Lite and Narrow – A narrow gauge coal tipplPart 2](#)

[Yes It's a Model – Monthly Photo Album](#)

[What’s Neat – The BLMA signal tower shoot](#)

---

[Other – Bonus Extras](#)

[Other – Cover](#)

[Other – Derailments](#)

[Other – Hobby Marketplace](#)

[Other – MRH Sponsors](#)

[Other – Staff Notes](#)

[Other – Table of Contents](#)

# The case against more detailed cars

## Reverse Running: Stepping outside the box with a contrary view

by Joe Fugate

**T**hese days it seems the ultimate in the hobby has become ever more detail on our models.

We've become so detail-hungry that manufacturers keep adding those details to satisfy us, to the point the typical ready-to-run HO freight car has gone from less than \$10 in the 1990s to now 20 years later pushing \$35-\$45.

I can remember when Kadee's more detailed HO freight cars priced in the \$25 range seemed very expensive. Now-a-days, a \$25 HO ready-to-run (RTR) freight car seems cheap!

Do we really need all this detail? If you're building an operating layout, especially a layout over 200 square feet in size, I would argue this level of detail *is overkill*.

When you're building a larger layout, you need lots of cars – often dozens of each kind of car, and hundreds of cars in total.

Let's say we're talking 200 cars in HO that you need, and let's say you can get them all as RTR models (that's debatable if you're a prototype modeler, but we'll go with it for now). If you can get all the cars you need for \$25, that's still a cool five grand! If you go fancy and pay closer to \$40 per car, now you're talking eight grand.

That box car costs  
**HOW MUCH?**



**Reader  
Feedback**  
(click here)



That three grand difference will buy you a very nice wireless DCC system with a bunch of fancy wireless throttles. In other words, that's a lot of money.

But beyond the money aspect, I would argue all that detail is largely a waste on a larger layout. When I'm doing prototype operations, I typically have a lot on my mind. If the car is reasonably weathered and has good basic details done in place, I frankly don't notice how much brake rigging or stand-off grab irons a car has.

Ask me later which cars in the train were \$40 uber-detailed and which cars were nicely weathered Blue Box specials with some detail upgrades like better stirrup steps and I could not tell you.

Yes, those super-detailed cars look great in up close model photos. But do they make the op session more fun? Not at all.

One big reason this detail is a waste is because when you're operating, the trains are moving. Have you ever tried to itemize car details on a car when it's in motion? It's tough to do. Or even if the train is standing still, the cars may be buried in yard track three or sitting in a passing siding while the hot freight rolls by in front on the main.

In short, we of the hobby media have done a disservice to the hobby by promoting all this super detailing. Sure it makes great photos, but as an industry we're killing doing the hobby-in-the-large by mere mortals – only the most wealthy need apply.

Isn't it time we decide enough is enough, and start promoting what's reasonable instead of pushing the level of detail ever higher and taking the price of your average HO freight car over \$50 in the next few years?

I mean, c'mon! It's time we modelers flock to the cheaper equipment and show the industry there's still a market for more affordable cars. Let's vote with our pocketbooks!



contents



index

# Derailments

humor and bizarre facts (allegedly)



If you missed your shower this morning, maybe the train can help ...

If you're the first to [submit a bit of good humor or bizarre facts](#) and we use it, it's worth \$25!



# For the love of model trains

## Coming in September

- Neil Schoffield builds Agway Feed
- Jeff Johnston on modeling logging cabooses
- Kitbashing an SP Commuter GP9
- How to do an H-beam turntable bow
- ...and lots more!

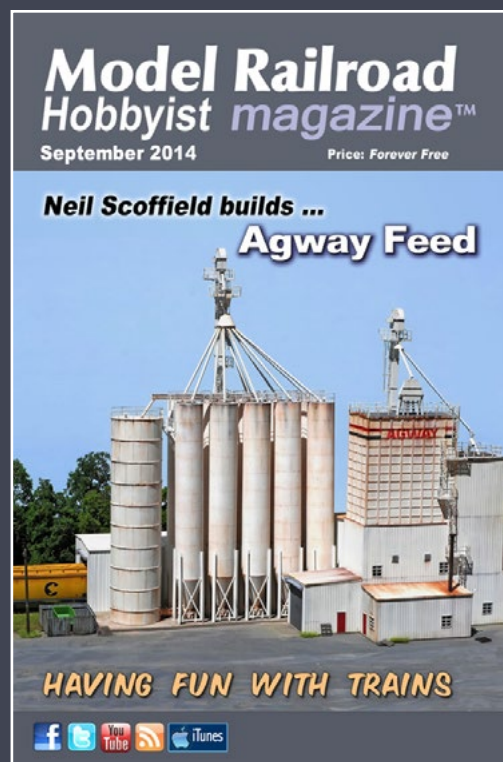

*More Derailments humor and bizarre facts ...*



Coming next issue



contents



index